

# **SWITEL**

**SWISS BRAND** 

**Strahlungsarmes schnurloses  
DECT-Telefon mit Anrufbeantworter**  
**Téléphone DECT sans fil, à faible  
rayonnement et avec répondeur**  
**Telefono cordless DECT a basse  
radiazioni con segreteria telefonica**  
**Low-radiation cordless DECT  
telephone with answering machine**



## **DFT 137x**

**Bedienungsanleitung**  
**Mode d'emploi**  
**Istruzioni per l'uso**  
**Operating Instructions**

**D**

**F**

**I**

**GB**

# ***SWITEL***

Bedienungsanleitung . . . . .	3
Mode d'emploi . . . . .	29
Istruzioni per l'uso . . . . .	55
Operating Instructions . . . . .	81
Declaration of Conformity . . . . .	108

1	Sicherheitshinweise .....	4
2	Telefon in Betrieb nehmen .....	5
3	Bedienelemente .....	7
4	Einführende Informationen .....	8
5	Telefonieren .....	10
6	Nebenstellenanlagen / Zusatzdienste .	12
7	Menüstruktur .....	13
8	Telefonbuch .....	15
9	Anruferliste .....	16
10	Erweitern des Telefonsystems .....	17
11	Anrufbeantworter .....	18
12	Falls es Probleme gibt .....	22
13	Technische Eigenschaften .....	24
14	Pflegehinweise / Garantie .....	26
15	Stichwortverzeichnis .....	27

# Sicherheitshinweise

## 1 Sicherheitshinweise

Lesen Sie diese Bedienungsanleitung sorgfältig durch.

### Bestimmungsgemäße Verwendung

Dieses Telefon ist geeignet zum Telefonieren innerhalb eines Telefonnetzes. Jede andere Verwendung gilt als nicht bestimmungsgemäß. Eigenmächtige Veränderungen oder Umbauten sind nicht zulässig. Öffnen Sie das Gerät in keinem Fall selbst und führen Sie keine eigenen Reparaturversuche durch.

### Aufstellungsort

Vermeiden Sie Belastungen durch Rauch, Staub, Erschütterungen, Chemikalien, Feuchtigkeit, Hitze oder direkte Sonneneinstrahlung. Verwenden Sie das Mobilteil nicht in explosionsgefährdeten Bereichen.

### Netzteil



**Achtung:** Verwenden Sie nur das mitgelieferte Steckernetzteil, da andere Netzteile das Telefon beschädigen können. Sie dürfen den Zugang zum Steckernetzteil nicht durch Möbel oder andere Gegenstände versperren.

### Aufladbares Akkupack



**Achtung:** Werfen Sie Akkus nicht ins Feuer. Verwenden Sie nur Akkus des gleichen Typs! Achten Sie auf die richtige Polung! Bei verkehrter Polung der Akkus besteht beim Aufladen Explosionsgefahr.

D

### Stromausfall

Bei Stromausfall kann mit diesem Telefon nicht telefoniert werden. Halten Sie für Notfälle ein schnurgebundenes Telefon bereit, welches ohne externe Stromversorgung arbeitet.

## Medizinische Geräte



**Achtung:** Benutzen Sie das Telefon nicht in der Nähe von medizinischen Geräten. Eine Beeinflussung kann nicht völlig ausgeschlossen werden.

DECT<sup>1</sup>-Telefone können in Hörgeräten einen unangenehmen Brummtönen verursachen.

### Hörgeräte-kompatibel

Das Telefon ist mit den meisten am Markt befindlichen Hörgeräten kompatibel. Eine einwandfreie Funktion mit jedem Hörgerät kann jedoch nicht garantiert werden.

### Entsorgung

Wollen Sie Ihr Gerät entsorgen, bringen Sie es zur Sammelstelle Ihres kommunalen Entsorgungsträgers (z. B. Wertstoffhof). Nach dem Elektro- und Elektronikgerätegesetz sind Besitzer von Altgeräten gesetzlich verpflichtet, alte **Elektro- und Elektronikgeräte** einer getrennten Abfallerfassung zuzuführen. Das nebenstehende Symbol bedeutet, dass Sie das Gerät auf keinen Fall in den Hausmüll werfen dürfen!



### Gefährdung von Gesundheit und Umwelt durch Akkus und Batterien!



Akkus und Batterien nie öffnen, beschädigen, verschlucken oder in die Umwelt gelangen lassen. Sie können giftige und umweltschädliche Schwermetalle enthalten. Sie sind gesetzlich verpflichtet, Akkus und Batterien beim batterievertreibenden Handel sowie bei zuständigen Sammelstellen, die entsprechende Behälter bereitstellen, sicher zu entsorgen. Die Entsorgung ist unentgeltlich. Die Symbole bedeuten, dass Sie Akkus und Batterien auf keinen Fall in den Hausmüll werfen dürfen und sie über Sammelstellen der Entsorgung zugeführt werden müssen.

**Verpackungsmaterialien** entsorgen Sie entsprechend den lokalen Vorschriften.

<sup>1</sup> DECT: Digital Enhanced Cordless Telecommunication = Standard für kabellose Telefone.

## 2 Telefon in Betrieb nehmen

### Sicherheitshinweise



**Achtung:** Lesen Sie vor der Inbetriebnahme unbedingt die Sicherheitshinweise in Kapitel 1.

### Verpackungsinhalt prüfen

Zum Lieferumfang gehören:

Inhalt	DFT 137X-Modell			
	DFT 1371	DFT 1372 <sup>1</sup>	DFT 1373 <sup>1</sup>	DFT 1374 <sup>1</sup>
Basisstation mit Netzteil	1	1	1	1
Ladestation mit Netzteil	-	1	2	3
Mobilteil	1	2	3	4
Telefonanschlusskabel	1	1	1	1
Akkupack	1	2	3	4
Bedienungsanleitung	1	1	1	1

<sup>1</sup> Unter [www.switel.com](http://www.switel.com) erfahren Sie, ob dieses Telefonset bereits erhältlich ist.

### Basisstation anschließen



**Achtung:** Stellen Sie die Basisstation mit einem Mindestabstand von 1 m zu anderen elektronischen Geräten auf, da es sonst zu gegenseitigen Störungen kommen kann.

Schließen Sie die Basisstation wie auf der Skizze abgebildet an. Verwenden Sie aus Sicherheitsgründen nur das mitgelieferte Netzteil sowie das beigelegte Telefonanschlusskabel.

Telefonanschlussdose



Netzsteckdose

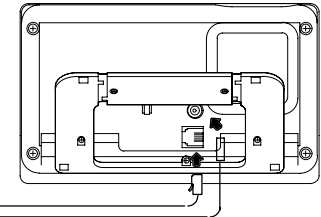

### Wichtiger Hinweis

Die Basisstation Ihres Telefons ist mit einem energieeffizienten Schaltnetzteil SSA-5AP-09EU060060 (Input 100~240 V<sub>AC</sub>, Output 6 V<sub>DC</sub>, 600 mA) ausgestattet. Die Nulllast beträgt ca. 0,15 W. Die durchschnittliche Effizienz beträgt ca. 65 %. Die Leistungsaufnahme der Basisstation beträgt:

- im Betrieb (Bereitschaft/Gespräch): ca. 1,5 W
- während der Ladung des Mobilteils: ca. 2,5 W

Die mit einem Telefonset gelieferte(n) Ladestation(en) ist/sind mit einem energieeffizienten Schaltnetzteil S002CV0600030 (Input 100~240 V<sub>AC</sub>, Output 6 V<sub>DC</sub>, 300 mA) ausgestattet.

Die Nulllast beträgt ca. 0,15 W.

Die durchschnittliche Effizienz beträgt ca. 60 %.

Die Leistungsaufnahme der Ladestation beträgt:

- ohne Mobilteil: ca. 0,15 W
- während der Ladung des Mobilteils: ca. 1,2 W

# Telefon in Betrieb nehmen

## Akkupack einlegen

Schieben Sie den Akkufachdeckel abwärts und nehmen Sie ihn anschließend ab. Stecken Sie den Stecker des Akkupacks in die Buchse im Akkufach. Legen Sie das Akkupack in das Akkufach ein. Verwenden Sie nur das mitgelieferte Akkupack. Achten Sie darauf, dass Sie das Kabel nicht einklemmen. Setzen Sie den Deckel wieder auf das Akkufach und schieben Sie ihn nach oben, bis er einrastet.

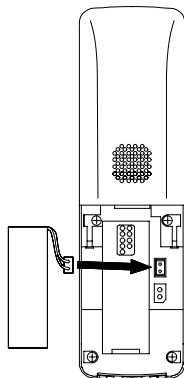

## Akkupack aufladen



Stellen Sie das Mobilteil bei der ersten Inbetriebnahme für **mindestens 16 Stunden** in die Basisstation / Ladestation.

Haben Sie das Mobilteil richtig in die Basisstation / Ladestation gestellt, leuchtet die Ladekontrollleuchte. Das Mobilteil erwärmt sich beim Laden. Dies ist normal und ungefährlich. Laden Sie das Mobilteil nicht mit fremden Aufladegeräten. Der aktuelle **Akkuladezustand** wird im Display angezeigt:



Voll



2/3 Voll



Schwach



Leer

## Datum und Uhrzeit des Mobilteils einstellen

Datum und Uhrzeit stellen Sie über das Menü ein. Auf Seite 14 finden Sie die Position im Menü.

## Nebenstellenanlagen

Auf Seite 12 erhalten Sie weitere Informationen, falls Sie Ihr Telefon an eine Nebenstellenanlage anschließen möchten.

## Strahlungsreduzierung (ECO-Mode)

Im Gesprächsmodus wird die Strahlung abhängig von der Entfernung des Mobilteils zur Basis verringert.



## 3 Bedienelemente

Die Tasten Ihres Telefons werden in dieser Bedienungsanleitung nachfolgend mit vereinheitlichten umrandeten Symbolen dargestellt. Leichte Abweichungen der Tastensymbole Ihres Telefons gegenüber den hier verwendeten Tastensymbolen sind daher möglich.

### Mobilteil

- 1 Hörer
- 2 Display
- 3 -Taste
- 4 Navigation aufwärts / Lautstärke erhöhen / Telefonbuch
- 5 Auflegen-Taste / Zurück / Löschen / Ausschalten
- 6 Navigation abwärts / Lautstärke verringern / Anruferliste
- 7 -Taste
- 8 Interngespräche
- 9 Mikrofonstummschaltung / Löschen
- 10 Mikrofon
- 11 Wahlwiederholung / Wahlpause einfügen
- 12 -Taste
- 13 Zifferntastenblock
- 14 Gesprächstaste / R-Taste
- 15 Freisprechen

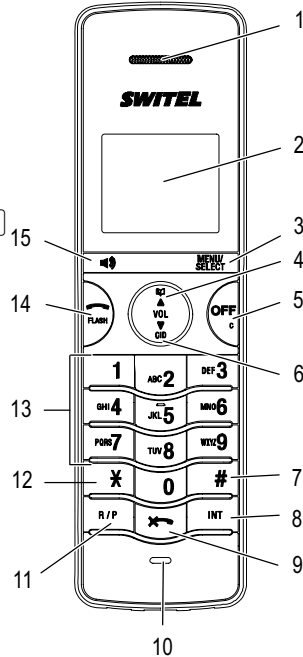

### Basisstation (Anrufbeantworter)

- 1 LED: Gesprächsanzeige
- 2 Mobilteil suchen (Paging)
- 3 Anrufbeantworter ein / aus
- 4 Löschen
- 5 Display
- 6 LED: Ladeanzeige
- 7 Lautstärke +
- 8 Lautstärke -
- 9 Nächste Nachricht
- 10 Wiedergabe/Stop
- 11 Nachricht wiederholen / Vorherige Nachricht
- 12 Lautsprecher
- 13 Ladkontakte

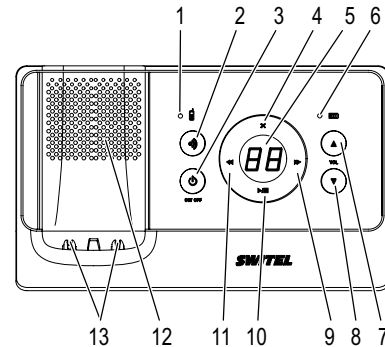











# Einführende Informationen

















## 4 Einführende Informationen

In diesem Kapitel finden Sie grundlegende Informationen zur Handhabung der Bedienungsanleitung und des Telefons.

### Darstellungsweise in der Bedienungsanleitung

Darstellung	Beschreibung
	Darstellung von Tasten
	Abgebildete Taste kurz drücken
3 Sek. 	Abgebildete Taste 3 Sekunden drücken
halten 	Abgebildete Taste halten
loslassen 	Abgebildete Taste loslassen
	Nummern oder Buchstaben eingeben
	Mobilteil klingelt
	Basisstation klingelt
	Mobilteil aus der Basisstation nehmen
	Mobilteil in die Basisstation stellen
<b>ANRUFLISTE</b>	Darstellung von Display-Texten
	Darstellung von Display-Symbolen

### Symbole und Texte im Display des Mobilteils

Symbol	Beschreibung
	Anzeige der Akkukapazität.
TT/MM	Anzeige des Datums  Seite 14.
hh:mm	Anzeige der Uhrzeit  Seite 14.
	Neuer Eintrag in der Anruferliste  Seite 16.
	Das Freisprechen ist aktiviert  Seite 11.
	Anrufbeantworter im Telefonnetz. <b>VMWI</b> <sup>1</sup> - Zusatzdienst Ihres Netzbetreibers  Seite 12.
	Das Mikrofon ist stummgeschaltet  Seite 11.
	Der Klingelton ist ausgeschaltet  Seite 13.
	Der Anrufbeantworter ist eingeschaltet  Seite 18.
	Es sind neue Nachrichten auf dem Anrufbeantworter.

<sup>1</sup> **VMWI: Visual Message Waiting Indication** = Optische Anzeige neuer Nachrichten.



## Stand-by-Modus













Alle Beschreibungen in dieser Bedienungsanleitung gehen davon aus, dass sich das Mobilteil im Stand-by-Modus befindet. Den Stand-by-Modus erreichen Sie, indem Sie die Taste  ggf. mehrfach drücken.

## Energiesparmodus

Nach einiger Zeit im Stand-by-Modus wechselt das Mobilteil in den Energiesparmodus. Tasten und Display sind nun nicht mehr beleuchtet.

## Navigation im Menü

Alle Funktionen sind über unterschiedliche Menüs zu erreichen. Den Weg zur gewünschten Funktion entnehmen Sie der Menüstruktur  Seite 13.







	Hauptmenü öffnen
 oder 	Gewünschtes Untermenü auswählen
	Untermenü öffnen
 oder 	Gewünschte Funktion auswählen
	Funktion öffnen
 oder 	Gewünschte Einstellung auswählen
	Über Tastenfeld Nummern oder Buchstaben eingeben
	Eingaben bestätigen
	Eine Ebene zurück
	Programmier- und Speichervorgänge abbrechen und in den Stand-by-Modus zurückkehren



Jeder Vorgang wird automatisch abgebrochen, wenn innerhalb von 30 Sekunden keine Eingabe erfolgt.

## Telefonbucheinträge erstellen - Beispiel

Wie Sie in den Menüs navigieren und Einstellungen vornehmen, ist hier anhand des Beispiels **Telefonbucheinträge erstellen** erklärt. Verfahren Sie bei allen Einstellungen wie in diesem Beispiel.

	Hauptmenü öffnen
 /  <b>TELEFONBUCH</b> , 	Telefonbuch auswählen und bestätigen
 /  <b>SPEICHERN</b> , 	Untermenü auswählen und bestätigen
<b>NR. EINGEBEN</b> ,  , 	Rufnummer eingeben (max. 30 Ziffern) und bestätigen
<b>NAME EINGEBEN</b> ,  , 	Namen eingeben (max. 15 Stellen) und speichern

# Telefonieren

## 5 Telefonieren

### Anruf annehmen

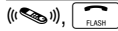

Anruf annehmen

### Gespräch beenden



Gespräch beenden

### Anrufen



Rufnummer eingeben (max. 30 Ziffern)



Bei Falscheingabe letzte Ziffer löschen



Rufnummer wählen



Sie können auch zuerst die Gesprächstaste drücken und erhalten damit das Freizeichen. Die eingegebenen Ziffern Ihrer gewünschten Rufnummer werden sofort gewählt. Eine Korrektur einzelner Ziffern der Rufnummer ist bei dieser Form des Gesprächsaufbaus nicht möglich.

### Wahlwiederholung

Ihr Telefon speichert die 5 zuletzt gewählten Rufnummern in einer Wahlwiederholungsliste.



Wahlwiederholungsliste öffnen



Eintrag auswählen und Verbindung herstellen

D

### Eingegangene Anrufe zurückrufen

Ihr Telefon speichert 50 Anrufe in einer Anruferliste.



Anruferliste öffnen

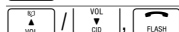

Eintrag auswählen und Verbindung herstellen

### Rufnummern aus dem Telefonbuch wählen

Sie müssen Rufnummern im Telefonbuch gespeichert haben  
☞ Seite 9 und 15.



Telefonbuch öffnen



Eintrag auswählen und Verbindung herstellen

### Intern telefonieren<sup>1</sup>

#### Interne Gespräche führen

Sie müssen zwei oder mehr Mobilteile (MT1, MT2, ...) an Ihrer Basisstation angemeldet haben, um interne kostenlose Gespräche führen zu können.

MT1: , z. B.

Interne Rufnummer des gewünschten Mobilteils wählen

MT2:

Internes Gespräch am anderen Mobilteil annehmen

MT1 / MT2:

Internes Gespräch beenden

#### Externe Gespräche intern weiterleiten

MT1: , z. B.

Während des externen Gesprächs interne Rufnummer wählen

MT2:

Internes Gespräch am anderen Mobilteil annehmen

MT1:

Gespräch weiterleiten





Sollte sich das gerufene Mobilteil nicht melden, können Sie sich das externe Gespräch zurückholen, indem Sie die Taste  drücken.

<sup>1</sup> Das interne Telefonieren ist nur mit mindestens zwei Mobilteilen möglich ☞ "Verpackungsinhalt prüfen" auf Seite 5.

## Rücksprache / Makeln

Während eines externen Gesprächs können Sie ein anderes Mobilteil anwählen, um Rücksprache zu halten. Der externe Gesprächspartner wird gehalten, während Sie mit dem internen Gesprächspartner sprechen. Diesen Vorgang können Sie beliebig oft wiederholen.



MT1: , z. B.  Während des externen Gesprächs interne Rufnummer wählen

MT2:  Internes Gespräch am anderen Mobilteil annehmen

MT1:  Gesprächspartner wechseln

## Konferenzgespräche führen

Ein externes Gespräch kann mit einem weiteren internen Gesprächspartner zum Konferenzgespräch geschaltet werden.

MT1: , z. B.  Während des externen Gesprächs interne Rufnummer wählen



MT2:  Internes Gespräch am anderen Mobilteil annehmen

MT1: halten  Konferenz starten

MT1 / MT2:  Konferenz beenden

## Einstellen der Hörerlautstärke

Sie können während eines Gesprächs die Lautstärke in 5 Stufen anpassen.

 oder  Gewünschte Lautstärke auswählen

## Freisprechen

Nutzen Sie diese Funktion, um den Gesprächspartner über den Lautsprecher zu hören.

 Freisprechen einschalten

 Freisprechen ausschalten

## Anzeige der Gesprächsdauer

Während eines Gesprächs wird die Gesprächsdauer in Stunden, Minuten und Sekunden angezeigt.

## Mikrofon im Mobilteil stummschalten

Sie können während eines Telefongesprächs das Mikrofon des Mobilteils aus- und einschalten.

 Mikrofon ausschalten (stummschalten)

 Mikrofon einschalten

## Mobilteil suchen (Paging)

Wenn Sie Ihr Mobilteil verlegt haben, können Sie es über einen Suchton leicht wiederfinden.

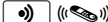
 Suchton starten

 oder  Suchton beenden

## Mobilteil aus- und einschalten

Um das Akkupack zu schonen, können Sie das Mobilteil ausschalten.

1 Sek. ,  Mobilteil ausschalten

5 Sek.  Mobilteil einschalten

# Nebenstellenanlagen / Zusatzdienste

## 6 Nebenstellenanlagen / Zusatzdienste

### R-Funktion an Nebenstellenanlagen

Ist Ihr Telefon an einer Nebenstellenanlage angeschlossen, können Sie über die -Taste Funktionen, wie z. B. Anrufe weiterleiten und automatischen Rückruf, nutzen. Lesen Sie bitte in der Bedienungsanleitung Ihrer Nebenstellenanlage, welche Flash-Zeit Sie zur Nutzung dieser Funktionen einstellen müssen. Ob Ihr Telefon an Ihrer Nebenstellenanlage einwandfrei funktioniert, erfahren Sie bei dem Händler, bei dem die Anlage gekauft wurde. Die Flash-Zeit stellen Sie über das Menü ein. Auf Seite 14 finden Sie die Position im Menü.

### R-Funktion und Zusatzdienste

Ihr Telefon unterstützt Zusatzdienste Ihres Netzbetreibers, wie z. B. Makeln, Anklopfen und Konferenz. Über die -Taste können Sie diese Zusatzdienste nutzen. Bitte fragen Sie Ihren Netzbetreiber, welche Flash-Zeit Sie zur Nutzung von Zusatzdiensten einstellen müssen. Zur Freischaltung von Zusatzdiensten wenden Sie sich bitte an Ihren Netzbetreiber. Die Flash-Zeit stellen Sie über das Menü ein. Auf Seite 14 finden Sie die Position im Menü.

### Rufnummernanzeige (CLIP<sup>1</sup>)



Die Rufnummernanzeige ist ein Zusatzdienst Ihres Netzbetreibers. Fragen Sie Ihren Netzbetreiber nach weiteren Informationen.

Wenn diese Funktion an Ihrer Telefonleitung zur Verfügung steht, wird Ihnen bereits die Rufnummer des Anrufers angezeigt, wenn das Telefon klingelt. Hat der Anrufer das Übertragen seiner Rufnummer unterdrückt, wird eine entsprechende Meldung angezeigt. Die Rufnummer kann nicht angezeigt und somit auch nicht in der Anruferliste gespeichert werden.

<sup>1</sup> **CLIP:** Calling Line Identification Presentation = Anzeige der Rufnummer eines Anrufers.

### Wahlpause

Bei Nebenstellenanlagen ist es erforderlich, eine Amtskennzahl vorzuwählen, um ein Freizeichen zu bekommen. Bei wenigen älteren Nebenstellenanlagen dauert es einige Zeit, bis das Freizeichen zu hören ist. Für diese Nebenstellenanlagen kann nach der Amtskennzahl eine Wahlpause eingefügt werden, um direkt weiterwählen zu können, ohne das Freizeichen abzuwarten.

2 Sek. 

Wahlpause einfügen

Nach der Amtskennzahl erfolgt die Wahl der eigentlichen Rufnummer nach einer bestimmten Zeit.



Die Wahlpause kann auch bei der Eingabe von Rufnummern im Telefonbuch gespeichert werden.

### Anrufbeantworter im Telefonnetz





Der Anrufbeantworter im Telefonnetz ist ein Zusatzdienst vieler Netzbetreiber. Wenn Ihr Netzbetreiber einen Anrufbeantworter im Telefonnetz für Sie bereitstellt, werden Sie mit einem Symbol über neue Nachrichten informiert (**VMWI<sup>2</sup>**). Über diese Funktion können Sie nur dann verfügen, wenn Ihr Netzbetreiber diesen Zusatzdienst anbietet. Bitte fragen Sie Ihren Netzbetreiber nach weiteren Informationen.

<sup>2</sup> **VMWI:** Visual Message Waiting Indication = Optische Anzeige neuer Nachrichten.

## 7 Menüstruktur

### Hauptmenü

In das Hauptmenü gelangen Sie durch Drücken der Taste . Wie Sie sich im Menü bewegen und Eingaben vornehmen, zeigt Ihnen Seite 9.

AB	NACHR. ABHÖREN		
	NACHR. LÖSCHEN		
	MEMO AUFZ.		
	EINSTELLUNGEN	AB EIN/AUS	EIN / AUS
		ANTWORTVERZ.	2 KL.ZEICHEN / 4 KL.ZEICHEN / 6 KL.ZEICHEN / 8 KL.ZEICHEN / GEBÜHRENSPARER
		ANSAGE-EINST.	AUFNEHMEN
			WDG.
	FERNABFRAGE	EIN / AUS	
	FERNABFR.-PIN	ALTE PIN <sup>1</sup> 	NEUE PIN  PIN BESTÄTIGEN 
	AB-HINWEISTON	EIN / AUS	
TELEFONBUCH	ANZEIGEN		
	SPEICHERN	NR. EINGEBEN 	NAME EINGEBEN 
ANRUFLISTE <sup>2</sup>	ANZEIGEN		
	ANR. LÖSCHEN		
RUFLAUTST.	AUS, RUFLAUTST. 1 - 6		









<sup>1</sup> Die PIN ist werkseitig auf "0000" eingestellt.

<sup>2</sup> Für das Anzeigen und Speichern von Rufnummern in Anruferlisten wird die Rufnummernanzeige (**CLIP**<sup>3</sup>) benötigt. Die Rufnummernanzeige ist ein Zusatzdienst Ihres Netzbetreibers. Fragen Sie Ihren Netzbetreiber nach weiteren Informationen. Weitere Informationen zur Rufnummernanzeige

 Seite 12.

<sup>3</sup> **CLIP**: Calling Line Identification Presentation = Anzeige der Rufnummer eines Anrufers.

# Menüstruktur

RUFZEICHEN	RUFZEICHEN 1 - 10		
TON-EINST.	TASTENTON	EIN / AUS	
	AKKUKAP.GERING	EIN / AUS	
	AUSSER REICHW.	EIN / AUS	
SPRACHE	DEUTSCH / ENGLISH / FRANÇAIS / ITALIANO		
MT ANMELDEN	SYSTEM-CODE: 	GEDRÜCKT HALTEN – PAGING-TASTE	
MT ABMELDEN	SYSTEM-CODE: 	MOBILTEIL X	MT ABMELDEN?
WAHLVERFAHREN	TONWAHL		
	IMPULSWAHL		
FLASH-ZEIT	KURZ / MITTEL / LANG		
DATUM/UHRZEIT	DATUM EINST. 	UHRZEIT EINST. 	
UHRZEITFORMAT	12-STUNDEN		
	24-STUNDEN		
DATUMSFORMAT	TT/MM/JJ / MM/TT/JJ		
MAILBOX LEEREN	SCHALTE ANZEIGE AUS?		
SYSTEM-CODE	ALTE PIN <sup>1</sup> 	NEUE PIN 	PIN BESTÄTIGEN 
ZURÜCKSETZEN	SYSTEM-CODE: 	ZURÜCKSETZEN?	

D

<sup>1</sup> Die PIN ist werkseitig auf "0000" eingestellt.

## 8 Telefonbuch

Im Telefonbuch können Sie 50 Rufnummern mit den dazugehörigen Namen speichern.

- Die Telefonbucheinträge sind alphabetisch geordnet. Um direkt zum gewünschten Telefonbucheintrag zu gelangen, drücken Sie den entsprechenden Anfangsbuchstaben.

### Namen eingeben

Die Zifferntasten sind mit Buchstaben beschriftet. Durch mehrmaliges Drücken der entsprechenden Taste können Buchstaben, Ziffern und Sonderzeichen eingegeben werden.

<b>1</b>	Leerzeichen eingeben
<b>X</b>	Zeichen löschen
<b>0</b>	Sonderzeichen eingeben



Um den gleichen Buchstaben zweimal einzugeben, drücken Sie die entsprechende Taste. Warten Sie, bis der Cursor eine Stelle weitergesprungen ist. Geben Sie den Buchstaben erneut ein.

### Telefonbucheinträge erstellen

<b>MENU/SELECT</b>	Hauptmenü öffnen
<b>1234567890X</b> / <b>VOL</b> <b>CD</b> <b>TELEFONBUCH</b>	Telefonbuch auswählen und bestätigen
<b>1234567890X</b> / <b>VOL</b> <b>CD</b> <b>SPEICHERN</b>	Untermenü auswählen und bestätigen
<b>NR. EINGEBEN</b> , <b>MENU/SELECT</b>	Rufnummer eingeben (max. 30 Ziffern) und bestätigen
<b>NAME EINGEBEN</b> , <b>MENU/SELECT</b>	Namen eingeben (max. 15 Stellen) und speichern

### Telefonbucheinträge ändern

<b>MENU/SELECT</b>	Hauptmenü öffnen
<b>1234567890X</b> / <b>VOL</b> <b>CD</b> <b>TELEFONBUCH</b>	Telefonbuch auswählen und bestätigen
<b>1234567890X</b> / <b>VOL</b> <b>CD</b> <b>ANZEIGEN</b>	Untermenü auswählen und bestätigen
<b>1234567890X</b> / <b>VOL</b> <b>CD</b> <b>MENU/SELECT</b>	Telefonbucheintrag auswählen und bestätigen
<b>NR. ÄNDERN</b> , <b>MENU/SELECT</b>	Rufnummer ändern und bestätigen
<b>NAME ÄNDERN</b> , <b>MENU/SELECT</b>	Namen ändern und speichern

### Telefonbucheinträge löschen

<b>MENU/SELECT</b>	Hauptmenü öffnen
<b>1234567890X</b> / <b>VOL</b> <b>CD</b> <b>TELEFONBUCH</b>	Telefonbuch auswählen und bestätigen
<b>1234567890X</b> / <b>VOL</b> <b>CD</b> <b>ANZEIGEN</b>	Untermenü auswählen und bestätigen
<b>1234567890X</b> / <b>VOL</b> <b>CD</b> <b>X</b>	Telefonbucheintrag auswählen und löschen

# Anruferliste

## 9 Anruferliste

Insgesamt werden 50 Rufnummern in einer Anruferliste gespeichert.



Die Rufnummernanzeige (**CLIP**<sup>1</sup>) ist ein Zusatzdienst Ihres Netzbetreibers. Ihr Telefon zeigt die Rufnummern im Display, wenn Ihr Netzbetreiber diesen Service anbietet. Bitte fragen Sie Ihren Netzbetreiber nach weiteren Informationen.

### Rufnummern aus der Anruferliste anzeigen

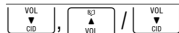

Anruferliste öffnen und Eintrag auswählen

### Eingegangene Anrufe zurückrufen

Ihr Telefon speichert 50 Anrufe in einer Anruferliste.



Anruferliste öffnen

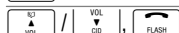

Eintrag auswählen und Verbindung herstellen

### Rufnummer aus der Anruferliste im Telefonbuch speichern

Eine Rufnummer kann direkt aus der Anruferliste im Telefonbuch gespeichert werden.



Anruferliste öffnen

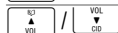

Eintrag auswählen



Funktion öffnen



Rufnummer ändern und bestätigen

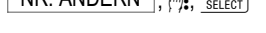

Namen ändern und speichern

### Rufnummern aus der Anruferliste löschen

#### Einzelne Rufnummer löschen



Anruferliste öffnen

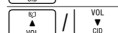

Eintrag auswählen



Eintrag löschen

#### Alle Rufnummern löschen



Anruferliste öffnen

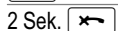

Löschvorgang aktivieren



Löschvorgang bestätigen oder abbrechen

<sup>1</sup> **CLIP**: Calling Line Identification Presentation = Anzeige der Rufnummer eines Anrufers.



## 10 Erweitern des Telefonsystems



### Mehrere Mobilteile

Sie können insgesamt 5 Mobilteile an Ihre Basisstation anmelden.

#### Anmelden von Mobilteilen

Bevor Sie ein Mobilteil anmelden, müssen Sie die Basisstation in den Registriermodus setzen. Halten Sie die Paging- Taste an der Basis gedrückt, bis Sie einen Signalton hören. Jetzt ist die Basis für einige Zeit im Registriermodus. Fahren Sie am Mobilteil fort.

5 Sek.  Registriermodus starten

Melden Sie nun das Mobilteil an  Seite 14. Benutzen Sie zur Anmeldung den aktuell eingestellten PIN-Code  Seite 14.

Nach dem Anmelden wird dem Mobilteil eine interne Rufnummer zugeteilt.

#### Abmelden von Mobilteilen



Jedes Mobilteil kann sich selbst oder andere an dieser Basisstation angemeldete Mobilteile abmelden. Im Display des abgemeldeten Mobilteils erscheint dann die Meldung NICHT ANGEMELD.

Mobilteile werden über das Menü abgemeldet. Auf Seite 14 finden Sie die Position im Menü.

# Anrufbeantworter

## 11 Anrufbeantworter

### Bedienung am Mobilteil

#### Einstellungsmenü öffnen

Die Einstellungen des Anrufbeantworters nehmen Sie über Ihr Mobilteil vor Seite 13.

#### Anrufbeantworter ein-/ausschalten

Über das Mobilteil können Sie den Anrufbeantworter ein-/ausschalten Seite 13.

#### Maximale Aufnahmezeit

Die maximale Aufnahmezeit beträgt 13 Minuten. Ist die Speicherkapazität für neue Nachrichten erschöpft, wird kein Anruf mehr aufgezeichnet.

#### Verzögerung der Anrufannahme

Sie können zwischen 2 bis 8 Tonrufen wählen. Zusätzlich können Sie die Einstellung GEBÜHRENSPARER für die gebührenfreie Vor-/Fernabfrage verwenden. Mit dieser Vor-/Fernabfrage können Sie gebührenfrei feststellen, ob sich neue Nachrichten auf Ihrem Anrufbeantworter befinden.

- Befinden sich neue Nachrichten auf Ihrem Anrufbeantworter, wird Ihr Anruf nach 2 Tonrufen angenommen.
- Befinden sich keine neuen Nachrichten auf Ihrem Anrufbeantworter, wird Ihr Anruf erst nach 4 Tonrufen angenommen. Legen Sie vor dem 4. Tonruf auf. So fallen keine Gebühren an.

Weitere Informationen über die Fernabfrage Seite 21.

#### Anruf übernehmen

Wenn der Anrufbeantworter bereits einen Anruf entgegengenommen hat, können Sie diesen übernehmen. Die Aufzeichnung der Nachricht wird in diesem Fall abgebrochen.



Anruf übernehmen

### Alarm bei aufgezeichneten Nachrichten

Wurde eine neue Nachricht oder ein Memo aufgezeichnet, ertönt alle 10 Sekunden ein Signalton Seite 13.

### Ansgen abspielen

	Hauptmenü öffnen
/ <b>AB</b> ,	Anrufbeantworter auswählen und bestätigen
/	Untermenü auswählen und bestätigen
<b>EINSTELLUNGEN</b> ,	
/ <b>ANSAGE-EINST.</b> ,	Untermenü auswählen und bestätigen
/ <b>WDG.</b> ,	Ansage wiedergeben

### Ansgen aufzeichnen

	Hauptmenü öffnen
/ <b>AB</b> ,	Anrufbeantworter auswählen und bestätigen
/	Untermenü auswählen und bestätigen
<b>EINSTELLUNGEN</b> ,	
/ <b>ANSAGE-EINST.</b> ,	Untermenü auswählen und bestätigen
/ <b>AUFNEHMEN</b> ,	Ansage aufzeichnen und bestätigen



JKI 5

Sprechen Sie den von Ihnen gewünschten Text klar und deutlich in das Mikrofon Ihres Mobilteils. Nach Beendigung wird Ihre Ansage laut wiederholt.

## Standardansagetext wieder aktivieren

	Hauptmenü öffnen
/ <b>AB</b>	Anrufbeantworter auswählen und bestätigen
/	Untermenü auswählen und bestätigen
<b>EINSTELLUNGEN</b> ,	
/ <b>ANSAGE-EINST.</b> ,	Untermenü auswählen und bestätigen
/ <b>WDG.</b> ,	Ansage wiedergeben
	Eigene Ansage während der Wiedergabe löschen

## Tastenfunktionen Nachrichtenmenü

Die folgende Tabelle verschafft Ihnen eine Übersicht über die jeweiligen Funktionen der einzelnen Tasten im Nachrichtenmenü.

Taste	Funktionen
/	Lautstärke einstellen
<b>DEF 3</b>	Nachricht während der Wiedergabe löschen
<b>GH 4</b>	Nachricht wiederholen
<b>2 x GH 4</b>	Vorherige Nachricht abhören
<b>JKL 5</b>	Wiedergabe der Nachricht wird gestoppt
<b>MNO 6</b>	Nächste Nachricht abhören
<b>OFF c</b>	Wiedergabe beenden

## Alle alten Nachrichten löschen

Es werden alle Nachrichten gelöscht.

	Hauptmenü öffnen
/ <b>AB</b> ,	Anrufbeantworter auswählen und bestätigen
/	
<b>NACHR. LÖSCHEN</b> ,	Löschvorgang einleiten
<b>LÖSCHE ALLE</b>	Löschvorgang bestätigen oder
<b>ALTEN NACHR.?</b> ,  / <b>OFF c</b>	abbrechen
	Gelöschte Nachrichten können nicht wiederhergestellt werden!

## Memo aufzeichnen

Ein Memo ist eine Mitteilung, die wie eine eingegangene Nachricht abgehört werden kann.

	Hauptmenü öffnen
/ <b>AB</b> ,	Anrufbeantworter auswählen und bestätigen
/ <b>MEMO AUFZ.</b> ,	Untermenü auswählen und bestätigen
<b>JKL 5</b>	Memo aufzeichnen und bestätigen

# Anrufbeantworter

## Bedienung an der Basis

### Anrufbeantworter ein-/ausschalten

 Anrufbeantworter ein-/ausschalten

### Lautstärke einstellen

Sie können die Lautstärke in 8 Stufen einstellen.

 Wiedergabe starten

 oder  Lautstärke einstellen (L1-L8)

### Aufgezeichnete Nachrichten abhören / löschen

#### Nachrichten abhören

Die aufgezeichneten Nachrichten werden in der Reihenfolge wiedergegeben, in der sie eingegangen sind.

 Nachrichten abhören/stoppen

 Nachricht wiederholen

2 x  Vorherige Nachricht

 Nächste Nachricht

#### Eine Nachricht löschen

 Zu löschende Nachricht abhören

 Während der Wiedergabe löschen

#### Alle alten Nachrichten löschen

 Gelöschte Nachrichten können nicht wiederhergestellt werden!

Es werden alle alten Nachrichten gelöscht.

 Wiedergabe starten

  Alle alten Nachrichten löschen

## Anrufbeantworterdisplay

Das Display des Anrufbeantworters zeigt den Status des Geräts an.

-- Anrufbeantworter ausgeschaltet

0-59 Anrufbeantworter eingeschaltet,  
Anzahl gespeicherter Nachrichten

0-59 blinkend Anrufbeantworter eingeschaltet,  
Anzahl neuer Nachrichten

r-ff Zugriff über ein Mobilteil oder die  
Fernabfrage

FF Speicher voll

## Fernabfrage

Sie können Ihren Anrufbeantworter anrufen, um Nachrichten abzuhe-  
ren und weitere Funktionen durchzuführen. Voraussetzung dafür ist  
ein Telefon mit Tonwahlfunktion.

### PIN-Code für die Fernabfrage

Der PIN-Code ist werkseitig auf "0000" eingestellt. Es wird empfohlen,  
den PIN-Code zu ändern. PIN-Code ändern ☞ Seite 13.

### Fernabfrage starten



Eigene Rufnummer wählen



Während der Ansage PIN-Code  
eingeben

Jetzt haben Sie die Möglichkeit, weitere Funktionen durchzuführen ☞  
Tabelle Tastenfunktionen der Fernabfrage.

### Ferneinschalten des Anrufbeantworters



Eigene Rufnummer wählen



Haben Sie vergessen, Ihren Anrufbeantworter einzuschal-  
ten, wird Ihr Anruf erst nach 10 Tonrufen angenommen.



Während der Ansage PIN-Code  
eingeben

**7**

Anrufbeantworter einschalten

Jetzt haben Sie die Möglichkeit, weitere Funktionen durchzuführen.

## Tastenfunktionen der Fernabfrage



Die Fernabfrage wird automatisch abgebrochen, wenn in-  
nerhalb von 30 Sekunden keine Eingabe erfolgt.

Die folgende Tabelle verschafft Ihnen eine Übersicht über die jewei-  
ligen Funktionen der einzelnen Tasten.

Taste	Funktionen wenn <u>keine</u> Nach- richten abgespielt werden	Funktionen wenn Nachrichten abgespielt werden
<b>2</b>		Nachricht während der Wie- dergabe löschen
2 x <b>2</b>	alle alten Nachrichten lö- schen	
<b>4</b>		Laufende Nachricht wieder- holen
2 x <b>4</b>		Vorherige Nachricht abhören
<b>5</b>	Nachrichten abspielen	Wiedergabe stoppen
<b>6</b>		Nächste Nachricht abhören
<b>7</b>	Anrufbeantworter einschalten	
<b>9</b>	Anrufbeantworter ausschalten	
	Fernabfrage beenden	Fernabfrage beenden

# Falls es Probleme gibt

## 12 Falls es Probleme gibt

### Service-Hotline



Haben Sie Probleme mit Ihrem Telefon, kontrollieren Sie zuerst die folgenden Hinweise. Bei technischen Problemen können Sie sich an unsere Service-Hotline unter Tel. 0900 00 1675 innerhalb der Schweiz (Kosten Swisscom bei Drucklegung: CHF 2.60/min) wenden. Bei Garantieansprüchen wenden Sie sich an Ihren Fachhändler. Die Garantiezeit beträgt 2 Jahre.

### Fragen und Antworten

Fragen	Antworten
Keine Verbindung zur Basisstation möglich	<ul style="list-style-type: none"><li>- Prüfen Sie, ob Sie sich mit dem richtigen PIN-Code an der Basisstation angemeldet haben ☞ Seite 14.</li></ul>
Kein Telefongespräch möglich	<ul style="list-style-type: none"><li>- Das Telefon ist nicht korrekt angeschlossen oder gestört. Verwenden Sie nur das mitgelieferte Telefonanschlusskabel.</li><li>- Testen Sie mit einem anderen Telefon, ob Ihr Telefonanschluss in Ordnung ist.</li><li>- Das Netzteil ist nicht eingesteckt oder es liegt ein totaler Stromausfall vor.</li><li>- Das aufladbare Akkupack ist leer oder defekt.</li><li>- Sie haben sich zu weit von der Basisstation entfernt.</li><li>- Wahlverfahren falsch eingestellt ☞ Seite 14.</li></ul>

Verbindung abgehackt, fällt aus	<ul style="list-style-type: none"><li>- Sie haben sich zu weit von der Basisstation entfernt.</li><li>- Falscher Aufstellungsort der Basisstation.</li></ul>
Das System reagiert nicht mehr	<ul style="list-style-type: none"><li>- Setzen Sie alle Funktionen über "ZURÜCKSETZEN" in den Werkzustand zurück ☞ Seite 14.</li><li>- Ziehen Sie kurzzeitig das Netzteil aus der Steckdose.</li></ul>
Das Akkupack ist in kürzester Zeit leer	<ul style="list-style-type: none"><li>- Das aufladbare Akkupack ist leer oder defekt.</li><li>- Stellen Sie das Mobilteil richtig auf die Basisstation. Reinigen Sie die Kontaktflächen am Mobilteil und an der Basisstation mit einem weichen trockenen Tuch.</li><li>- Stellen Sie das Mobilteil für 16 Stunden in die Basisstation.</li></ul>
Die Rufnummernanzeige (CLIP <sup>1</sup> ) funktioniert nicht	<ul style="list-style-type: none"><li>- Die Rufnummernanzeige ist ein Zusatzdienst Ihres Netzbetreibers. Bitte fragen Sie Ihren Netzbetreiber nach weiteren Informationen.</li><li>- Der Anrufer hat das Übertragen seiner Rufnummer unterdrückt.</li></ul>

<sup>1</sup> CLIP: Calling Line Identification Presentation = Anzeige der Rufnummer eines Anrufers.

Der Anrufbeantworter nimmt keine Nachrichten auf	<ul style="list-style-type: none"><li>- Stellen Sie sicher, dass der Anrufbeantworter eingeschaltet ist.</li><li>- Prüfen Sie, ob der Speicher des Anrufbeantworters voll ist. Löschen Sie ggf. Nachrichten aus dem Speicher  Seite 19.</li></ul>
Sie können keine Fernabfrage durchführen	<ul style="list-style-type: none"><li>- Prüfen Sie, ob Sie den richtigen Sicherheitscode für die Fernabfrage benutzen  Seite 13.</li><li>- Das Telefon, das Sie für die Fernabfrage nutzen, muss auf Tonwahlverfahren eingestellt sein.</li></ul>

# Technische Eigenschaften

## 13 Technische Eigenschaften

### Technische Daten

Merkmal	Wert
Standard	<b>DECT<sup>1</sup></b>
Stromversorgung (Basisstation)	Eingang: 100-240 V, 50/60 Hz Ausgang: 6 V 600 mA
Stromversorgung (Ladestation)	Eingang: 100-240 V, 50/60 Hz Ausgang: 6 V 300 mA
Reichweite	Außen: ca. 300 m Innen: ca. 50 m
Stand-by-Zeit	Bis zu 100 h
Max. Gesprächsdauer	Bis zu 8 h
Aufladbares Akkupack	NiMH 2,4 V 500 mAh
WAHLVERFAHREN	TONWAHL IMPULSWAHL
FLASH-ZEIT	100 ms, 300 ms, 600 ms

<sup>1</sup> **DECT**: Digital Enhanced Cordless Telecommunication = Standard für kabellose Telefone.

### Werkseinstellungen

#### Mobilteil

Die Werkseinstellungen werden über das Menü wiederhergestellt. Auf Seite 14 finden Sie die Position im Menü.

RUFLAUTST.	RUFLAUTST. 3
RUFZEICHEN	RUFZEICHEN 2
TASTENTON	EIN
AKKUKAP.GERING	EIN
AUSSER REICHW.	EIN
SPRACHE	DEUTSCH
UHRZEITFORMAT	24-STUNDEN
DATUMSFORMAT	TT/MM/JJ

#### Basisstation

Die Werkseinstellungen werden über das Menü wiederhergestellt. Auf Seite 14 finden Sie die Position im Menü.

RUFLAUTST.	3
WAHLVERFAHREN	TONWAHL
FLASH-ZEIT	KURZ
SYSTEM-CODE	0000



### Anrufbeantworter

AB EIN/AUS	EIN
ANTWORTVERZ.	6 KL.ZEICHEN
AB-HINWEISTON	EIN
FERNABFR.-PIN	0000

### Konformitätserklärung

Dieses Gerät erfüllt die Anforderungen der EU-Richtlinie: 1999/5/EG Richtlinie über Funkanlagen und Telekommunikationsendeinrichtungen und die gegenseitige Anerkennung ihrer Konformität. Die Konformität mit der o. a. Richtlinie wird durch das CE-Zeichen auf dem Gerät bestätigt. Für die komplette Konformitätserklärung nutzen Sie bitte den kostenlosen Download von unserer Website [www.switel.com](http://www.switel.com).



# Pflegehinweise / Garantie

## 14 Pflegehinweise / Garantie

### Pflegehinweise

- Reinigen Sie die Gehäuseoberflächen mit einem weichen und fusselfreien Tuch.
- Verwenden Sie keine Reinigungs- oder Lösungsmittel.

### Garantie

SWITEL - Geräte werden nach den modernsten Produktionsverfahren hergestellt und geprüft. Ausgesuchte Materialien und hoch entwickelte Technologien sorgen für einwandfreie Funktion und lange Lebensdauer. Ein Garantiefall liegt nicht vor, wenn die Ursache einer Fehlfunktion des Geräts bei dem Telefonnetzbetreiber oder einer eventuell zwischengeschalteten Nebenstellenanlage liegt. Die Garantie gilt nicht für die in den Produkten verwendeten Batterien, Akkus oder Akkupacks. Die Garantiezeit beträgt 24 Monate, gerechnet vom Tage des Kaufs.

Innerhalb der Garantiezeit werden alle Mängel, die auf Material- oder Herstellungsfehler zurückzuführen sind, kostenlos beseitigt. Der Garantieanspruch erlischt bei Eingriffen durch den Käufer oder durch Dritte. Schäden, die durch unsachgemäße Behandlung oder Bedienung, natürliche Abnutzung, durch falsches Aufstellen oder Aufbewahren, durch unsachgemäßen Anschluss oder Installation sowie durch höhere Gewalt oder sonstige äußere Einflüsse entstehen, fallen nicht unter die Garantieleistung. Wir behalten uns vor, bei Reklamationen die defekten Teile auszubessern, zu ersetzen oder das Gerät auszutauschen. Ausgetauschte Teile oder ausgetauschte Geräte gehen in unser Eigentum über. Schadenersatzansprüche sind ausgeschlossen, soweit sie nicht auf Vorsatz oder grober Fahrlässigkeit des Herstellers beruhen.

Sollte Ihr Gerät dennoch einen Defekt innerhalb der Garantiezeit aufweisen, wenden Sie sich bitte unter Vorlage Ihrer Kaufquittung ausschließlich an das Geschäft, in dem Sie Ihr SWITEL - Gerät gekauft haben. Alle Gewährleistungsansprüche nach diesen Bestimmungen sind ausschließlich gegenüber Ihrem Fachhändler geltend zu machen. Nach Ablauf von zwei Jahren nach Kauf und Übergabe unserer Produkte können Gewährleistungsrechte nicht mehr geltend gemacht werden.

## 15 Stichwortverzeichnis

### A

Abhören, 20  
 Abmelden, 17  
 Abspielen, 18  
 Akkuladestatus, 6  
 Akkupack einlegen, 6  
 Alarm, 18  
 Anmelden, 17  
 Anrufannahme, 10  
 Anrufbeantworter, 18  
 Anrufbeantworter im Telefonnetz, 12  
 Anrufen, 10  
 Anruferliste, 16  
 Anrufübernahme, 18  
 Ansagen, 18  
 Aufladen, 6  
 Auflegen, 10  
 Aufzeichnen, 18  
 Ausschalten, 11

### B

Basisstation, 5, 7  
 Bedienelemente, 7  
 Bedienung, 8  
 Bedienung am Mobilteil, 18  
 Bedienung an der Basis, 20

### C

CLIP, 12

### D

Datum, 6  
 Display, 8, 20  
 Displaysymbole, 8

### E

ECO-Mode, 6  
 Einschalten, 11  
 Einstellungsmenü, 18  
 Energiesparmodus, 9  
 Erweiterung, 17

### F

Fehlerbehebung, 22  
 Fernabfrage, 21  
 Feineinschalten, 21  
 Fragen und Antworten, 22  
 Freisprechen, 11

### G

Garantie, 26  
 Gebührensparer, 18  
 Gespräch beenden, 10  
 Gesprächsdauer, 11  
 Gesprächsweiterleitung, 10

### H

Hauptmenü, 13  
 Hörerlautstärke, 11

### I

Inbetriebnahme, 5  
 Interngespräche, 10

### K

Konferenzgespräche, 11  
 Konformitätserklärung, 25

### L

Lautstärke, 20  
 Löschen, 19, 20

### M

Makeln, 11  
 Maximale Aufnahmezeit, 18  
 Memo aufzeichnen, 19  
 Menüstruktur, 13  
 Mikrofonstummuschaltung, 11  
 Mobilteil, 17  
 Mobilteil suchen, 11

### N

Nachrichten, 20  
 Nachrichten löschen, 20  
 Namenseingabe, 15  
 Nebenstellenanlagen, 12

### P

Paging, 11  
 Pflegehinweise, 26  
 PIN-Code, 21  
 Probleme, 22

### R

R-Funktion, 12  
 Rückruf, 10, 16  
 Rücksprache, 11  
 Rufnummernanzeige, 12, 16

### S

Schreibweisen, 8  
 Service-Hotline, 22  
 Sicherheitshinweise, 4  
 Speichern, 9, 15, 16  
 Stand-by-Modus, 9  
 Strahlungsreduzierung, 6  
 Stummuschaltung, 11  
 Symbole, 8

### T

Tastenfunktionen, 19, 21  
 Technische Daten, 24  
 Telefonbuch, 10, 15  
 Telefonbucheinträge, 9, 15  
 Telefonieren, 10  
 Texteingabe, 15

### U

Uhrzeit, 6

### V

Verpackungsinhalt, 5  
 Verzögerung, 18  
 VMWI, 12

### W

Wählen, 10  
 Wahlpause, 12  
 Wahlwiederholung, 10  
 Weiterleitung, 10  
 Werkseinstellungen, 24

### Z

Zusatzdienste, 12



1	Consignes de sécurité . . . . .	30
2	Mettre le téléphone en service . . . . .	31
3	Éléments de manipulation . . . . .	33
4	Introduction . . . . .	34
5	Téléphoner . . . . .	36
6	Installations PABX / Services confort .	38
7	Structure du menu . . . . .	39
8	Répertoire . . . . .	41
9	Liste d'appels . . . . .	42
10	Élargissement du système téléphonique	43
11	Répondeur . . . . .	44
12	En cas de problèmes . . . . .	48
13	Caractéristiques techniques . . . . .	50
14	Remarques d'entretien / Garantie . . . .	52
16	Index . . . . .	53

# Consignes de sécurité

## 1 Consignes de sécurité

Lisez très attentivement ce mode d'emploi.

### Utilisation conforme à l'usage

Ce téléphone convient pour téléphoner à l'intérieur d'un réseau téléphonique. Toute autre utilisation est considérée comme non conforme à son usage. Des modifications ou transformations effectuées de façon arbitraire ne sont pas autorisées. N'ouvrez en aucun cas l'appareil et ne tentez pas de le réparer vous-même.

### Lieu d'installation

Évitez les nuisances causées par la fumée, la poussière, les vibrations, les produits chimiques, l'humidité, la grande chaleur ou un ensoleillement direct.

Ne vous servez pas du combiné dans des endroits exposés aux explosions.

### Bloc secteur



**Attention :** N'utilisez que le bloc d'alimentation fourni avec l'appareil, d'autres pouvant endommager votre téléphone. Vous ne devez pas bloquer l'accès au bloc secteur par des meubles ou d'autres objets.

### Pack de piles rechargeables



**Attention :** Ne jetez jamais les piles rechargeables dans le feu. N'utilisez que des piles rechargeables du même type ! Observez une polarisation correcte ! Risque d'explosion lors de leur chargement si la polarisation est incorrecte.

### Panne de courant

En cas de panne de courant, il ne vous est pas possible de téléphoner avec cet appareil. Pour les cas d'urgence, prévoyez un téléphone avec fil fonctionnant sans alimentation externe en courant.

### Compatible avec les appareils auditifs

Ce téléphone est compatible avec la plupart des aides auditives en vente sur le marché. Cependant, un fonctionnement irréprochable ne peut être garanti pour chacune d'entre elles.

## Appareils médicaux



**Attention :** N'utilisez pas ce téléphone à proximité d'appareils médicaux. Un brouillard provoqué par celui-ci ne pouvant pas être entièrement exclu.

Les téléphones **DECT**<sup>1</sup> peuvent causer un bourdonnement désagréable dans les aides auditives.

## Élimination

Si vous voulez mettre votre appareil au rebut, veuillez l'apporter au centre de collecte de l'organisme d'élimination des déchets de votre commune (par ex. centre de recyclage). D'après la loi relative aux appareils électriques et électroniques, les propriétaires d'**appareils électriques et électroniques** usagés sont tenus de les déposer dans un collecteur séparé.

L'icône ci-contre signifie que vous ne devez en aucun cas jeter votre appareil dans les ordures ménagères !

**Mise en danger de l'homme et pollution de l'environnement causées par les piles et les piles rechargeables !**



Ne jamais ouvrir, endommager, avaler les piles rechargeables et les piles ou ne jamais faire pénétrer leur contenu dans l'environnement. Elles peuvent contenir des métaux lourds toxiques et nuisibles pour celui-ci. Vous êtes tenus par la loi d'éliminer vos piles rechargeables et piles auprès d'un revendeur de piles ainsi qu'auprès de centres de collecte responsables de leur élimination qui mettent des conteneurs adéquats à disposition. L'élimination des piles est gratuite. L'icône ci-contre signifie que vous ne devez en aucun cas jeter les piles rechargeables et piles dans les ordures ménagères, mais que vous devez les éliminer auprès de centres de collecte.

Éliminez les **fournitures d'emballage** conformément au règlement local.

<sup>1</sup> **DECT** : Digital Enhanced Cordless Telecommunication = Standard pour les téléphones sans fil.

## 2 Mettre le téléphone en service

### Remarques concernant la sécurité



**Attention** : Avant de mettre votre appareil en service, lisez impérativement les consignes de sécurité mentionnées au chapitre 1.

### Vérifier le contenu du coffret

Les éléments suivants font partie du coffret :

Contenu	Modèle DFT 137x			
	DFT 1371	DFT 1372 <sup>1</sup>	DFT 1373 <sup>1</sup>	DFT 1374 <sup>1</sup>
Base avec bloc secteur	1	1	1	1
Station d'accueil avec bloc secteur	-	1	2	3
Combiné	1	2	3	4
Câble de raccordement téléphonique	1	1	1	1
Pack de piles rechargeables	1	2	3	4
Mode d'emploi	1	1	1	1

<sup>1</sup> Le site [www.switel.com](http://www.switel.com) vous indiquera si cet ensemble téléphonique est déjà disponible.

### Raccorder la base



**Attention** : Posez la base à une distance minimum d'1 m par rapport à d'autres appareils électroniques, une distance inférieure pouvant provoquer des interactions.

Raccordez la base comme représenté sur le croquis. Pour des raisons de sécurité, n'utilisez que le bloc secteur ainsi que le câble de raccordement téléphonique fournis avec l'appareil.

Prise de raccordement téléphonique



Prise réseau

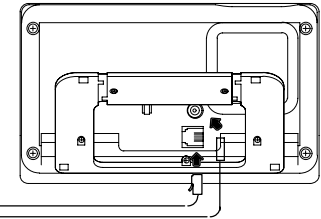

### Note importante

La station de base de votre téléphone est équipée d'une alimentation à découpage SSA-5AP-09EU060060 à haut rendement énergétique (entrée 100~240 V<sub>AC</sub>, sortie 6 V<sub>DC</sub>, 600 mA). Sans charge, le courant entrant s'élève à env. 0,15 W. Le rendement moyen est d'env. 65 %.

Puissance absorbée de la station de base :

- en mode de fonctionnement (disponible/conversation) : env. 1,5 W
- pendant le chargement du combiné : env. 2,5 W

La(Les) station(s) de chargement livrée(s) avec un set de téléphone est (sont) équipée(s) d'une alimentation à découpage S002CV0600030 à haut rendement énergétique (entrée 100~240 V<sub>AC</sub>, sortie 6 V<sub>DC</sub>, 300 mA). Sans charge, le courant entrant s'élève à 0,15 W. Le rendement moyen est d'env. 60 %.

Puissance absorbée de la station de chargement :

- sans le combiné : env. 0,15 W
- pendant le chargement du combiné : env. 1,2 W

## Mettre le téléphone en service

### Mettre en place le pack de piles rechargeables

Poussez le cache batterie vers le bas et retirez-le. Enfoncez la fiche du pack de piles rechargeables dans la prise située dans le compartiment à piles. Insérez le pack dans le compartiment. N'utilisez que le pack de piles rechargeables fourni avec l'appareil. Veillez à ne pas coincer le câble. Reposez le cache sur le compartiment à piles et poussez-le vers le haut jusqu'à ce qu'il s'enclenche.

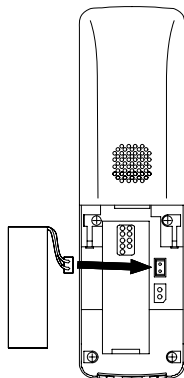

### Recharger le pack de piles rechargeables

 Lors de la première mise en service, laissez le combiné pendant **au moins 16 heures** sur la base / la station d'accueil.

Si vous avez placé le combiné correctement sur la base / station d'accueil, le voyant de contrôle de charge s'allume. Le combiné chauffe lors de la charge. Ceci est normal et sans danger. Ne chargez pas le combiné avec des chargeurs d'autres fabricants. Le **niveau de chargement des piles rechargeables** est affiché à l'écran :



Plein



2/3 Pleine



Faible



Vide

### Programmer l'heure et la date du combiné

Vous programmez la date et l'heure via le menu. La page 40 vous donnera la position dans le menu.

### Installations PABX

La page 38 vous donnera de plus amples informations au cas où vous désiriez raccorder votre téléphone à une installation PABX.

### Réduction du rayonnement (mode ÉCO)

En mode de communication, le rayonnement est réduit en fonction de l'éloignement du combiné par rapport à la base.















## 3 Éléments de manipulation







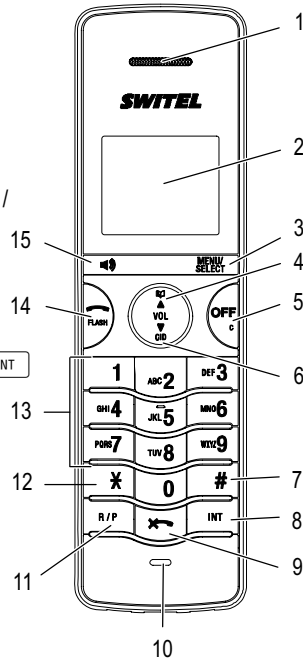



Dans ce mode d'emploi, les touches de votre téléphone sont représentées par des icônes encadrées standardisées. Il peut donc y avoir de légères différences entre les icônes des touches de votre téléphone et celles des touches utilisées ici.

### Combiné

- 1 Écouteur
- 2 Écran
- 3 Touche 
- 4 Navigation vers le haut/  
Augmenter le volume /  
Répertoire 
- 5 Touche Raccrocher / Retour /  
Effacer / Éteindre 
- 6 Navigation vers le bas/  
Diminuer le volume /  
Liste d'appels 
- 7 Touche 
- 8 Communications internes 
- 9 Désactivation du micro /  
Effacer 
- 10 Microphone
- 11 Touche bis /  
Introduire une pause  
de numérotation 
- 12 Touche 
- 13 Pavé numérique
- 14 Touche de communication /  
Touche R 
- 15 Mode mains-libres 



### Base (répondeur)

- 1 LED : affichage de communications 
- 2 Chercher un combiné (Paging) 
- 3 Répondeur allumé / éteint 
- 4 Effacer 
- 5 Écran
- 6 LED : affichage du niveau de charge 
- 7 Volume + 
- 8 Volume - 
- 9 Message suivant 
- 10 Écoute / Arrêt 
- 11 Répéter le message /  
Message précédent 
- 12 Haut-parleur
- 13 Contacts de chargement

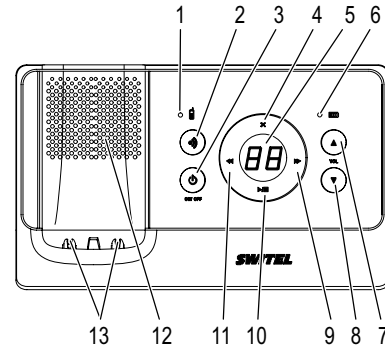













# Introduction

















## 4 Introduction

Vous trouverez dans ce chapitre des informations de base vous expliquant comment vous servir du mode d'emploi et du téléphone.

### Mode de représentation dans le mode d'emploi

Visualisation	Description
	Visualisation des touches
	Appuyer brièvement sur la touche représentée
3 sec. 	Appuyer 3 secondes sur la touche représentée
Maintenir 	Maintenir appuyée la touche représentée
Relâcher 	Relâcher la touche représentée
	Saisir des chiffres ou des lettres
	Le combiné sonne
	La base sonne
	Retirer le combiné de la base
	Poser le combiné sur la base
	Visualisation des textes de l'écran
	Visualisation des icônes de l'écran

### Icônes et textes à l'écran du combiné

Icône	Description
	Affichage de la capacité de la pile rechargeable.
TT/MM	Affichage de la date  page 40
hh:mm	Affichage de l'heure  page 40
	Nouveau contact dans la liste d'appels  page 42.
	Le mode mains-libres est activé  page 37.
	Répondeur dans le réseau téléphonique. <b>Service confort VMWI<sup>1</sup></b> de votre opérateur  page 38.
	Le microphone est programmé sur secret  page 37.
	La sonnerie est désactivée  page 39.
	Le répondeur est allumé  page 44.
	De nouveaux messages se trouvent sur le répondeur.

<sup>1</sup> **VMWI: Visual Message Waiting Indication** = Affichage optique de nouveaux messages.

## Mode veille













Toutes les descriptions de ce mode d'emploi partent du fait que le combiné se trouve en mode veille. Vous parvenez au mode veille en appuyant sur la touche  plusieurs fois, le cas échéant.

## Mode économie d'énergie

Après avoir été quelque temps en mode veille, le combiné passe au mode économie d'énergie. Touches et écran ne sont plus éclairés.

## Navigation dans le menu

Vous pouvez accéder à toutes les fonctions via différents menus. La structure de menu vous montre comment accéder à la fonction désirée  page 39.











	Ouvrir le menu principal
 ou 	Sélectionner le sous-menu désiré
	Ouvrir le sous-menu
 ou 	Sélectionner la fonction désirée
	Ouvrir la fonction
 ou 	Sélectionner le réglage désiré
	Saisir des chiffres ou des lettres via le pavé numérique
	Confirmer les entrées
	Reculer d'un niveau
	Annuler les opérations de programmation et de sauvegarde et retourner en mode veille



Chaque opération est automatiquement interrompue si vous n'effectuez pas de saisie dans les 30 secondes.

## Créer des enregistrements du répertoire - exemple

L'exemple **Ajouter des contacts dans le répertoire** vous explique ici comment naviguer dans les menus et réaliser des réglages. Pour toutes les programmations, procédez comme dans cet exemple.

	Ouvrir le menu principal
 /  <b>RÉPERTOIRE</b> , 	Sélectionner le répertoire et valider
 /  <b>PROGRAMMER</b> , 	Sélectionner le sous-menu et valider
<b>ENTRER NUMÉRO</b> ,  , 	Entrer le numéro (max. 30 chiffres) et valider
<b>ENTRER LE NOM</b> ,  , 	Entrer le nom (max. 15 caractères) et sauvegarder

# Téléphoner

## 5 Téléphoner

### Prendre un appel

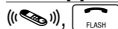

Décrocher

### Terminer la communication



Fin d'appel

### Appeler



Composer le numéro d'appel (max. 30 chiffres)



Si la saisie est erronée, effacer le dernier chiffre



Composer le numéro d'appel



Vous pouvez aussi appuyer d'abord sur la touche de communication ; vous obtenez ainsi la tonalité. Les chiffres saisis de votre numéro d'appel seront immédiatement composés. Une correction individuelle des chiffres du numéro n'est pas possible quand la communication est établie de cette manière.

### Répétition des derniers numéros

Votre téléphone enregistre les 5 derniers numéros composés dans une liste de répétition automatique des derniers numéros.



Ouvrir la liste de répétition des derniers numéros



Sélectionner le contact et établir la communication

### Rappeler des numéros d'appel entrés

Votre téléphone enregistre 50 appels dans une liste d'appels.



Ouvrir la liste d'appels



Sélectionner le contact et établir la communication

### Composer des numéros d'appel à partir du répertoire

Vous devez avoir enregistré des numéros dans le répertoire page 35 et 41.



Ouvrir le répertoire

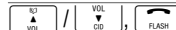

Sélectionner le contact et établir la communication

### Téléphoner en interne<sup>1</sup>

#### Téléphoner en interne

Vous devez avoir déclaré deux ou plusieurs combinés (CB1, CB2, ...) sur votre base afin de pouvoir téléphoner gratuitement en interne.

MT1: INT, par ex. ABC 2

Composer le numéro d'appel interne du combiné de votre choix

MT2: FLASH

Prendre la communication interne sur l'autre combiné

MT1 / MT2: OFF C

Terminer la communication interne

#### Transférer des communications externes en interne

MT1: INT, par ex. ABC 2

Composer le numéro d'appel interne pendant la communication externe

MT2: FLASH

Prendre la communication interne sur l'autre combiné

MT1: OFF C

Transférer la communication





Si le combiné appelé devait ne pas répondre, vous pouvez reprendre la communication externe en appuyant sur la touche OFF C.

<sup>1</sup> Téléphoner en interne n'est possible qu'avec au moins deux combinés ☞ "Contrôler le contenu du coffret" à la page 31.

## Intercommunication / Va-et-vient

Vous pouvez, pendant une communication externe, composer le numéro d'un autre combiné, pour intercommuniquer. Le correspondant externe sera maintenu en ligne pendant que vous parlez avec le correspondant interne. Vous pouvez répéter cette opération autant de fois que vous le désirez.



MT1: , par ex.  Composer le numéro d'appel interne pendant la communication externe

MT2:  Prendre la communication interne sur l'autre combiné

MT1:  Changer de correspondant

## Mener des conférences téléphoniques

Une communication externe peut être branchée sur un autre correspondant interne dans le but de mener une conférence.

MT1: , par ex.  Composer le numéro d'appel interne pendant la communication externe

MT2:  Prendre la communication interne sur l'autre combiné

MT1: Maintenir  Démarrer la conférence

MT1 / MT2:  Terminer la conférence

## Régler le volume sonore de l'écouteur

Vous disposez de 5 niveaux pour régler le volume pendant une communication.

 ou  Sélectionner le réglage désiré

## Mode mains-libres

Utilisez cette fonction pour entendre le correspondant par l'intermédiaire du haut-parleur.

 Activer le mode mains-libres

 Désactiver le mode mains-libres

## Affichage de la durée de la communication

Pendant une communication, sa durée s'affiche en heures, minutes et secondes.

## Mettre le microphone du combiné sur muet

Pendant une communication, vous pouvez activer et désactiver le microphone du combiné.

 Désactiver le microphone (le mettre sur silencieux)

 Activer le microphone

## Chercher le combiné (paging)

Si vous avez égaré votre combiné, vous pouvez le retrouver facilement grâce à un son de recherche.

  Lancer le son de recherche

 ou  Arrêter le son de recherche

## Allumer et éteindre le combiné

Vous pouvez éteindre le combiné pour ménager le pack de piles rechargeables.

1 sec. ,  Éteindre le combiné

5 sec.  Allumer le combiné

# Installations PABX / Services confort

## 6 Installations PABX / Services confort

### Fonction R sur les installations à postes supplémentaires

Si votre téléphone est raccordé à une installation PABX, vous pouvez, au moyen de la touche , tirer profit de certaines fonctions comme par ex. le transfert d'appels et le rappel automatique. Veuillez lire dans le mode d'emploi de votre installation PABX le temps de flash à paramétrer pour l'utilisation de ces fonctions. Le revendeur auprès duquel vous avez acheté l'installation vous dira si votre téléphone fonctionne parfaitement sur votre installation PABX. Le temps de flash se paramètre via le menu. La page 40 vous donnera la position dans le menu.

### Fonction R et services confort

Votre téléphone supporte des services confort de votre opérateur tels que le va-et-vient, la signalisation d'appel en instance et la conférence. Vous pouvez utiliser ces services supplémentaires par l'intermédiaire de la touche . Demandez à votre opérateur le temps de flash à paramétrer pour utiliser ces services conforfs. Contactez-le pour déconnecter ces services. Le temps de flash se paramètre via le menu. La page 40 vous donnera la position dans le menu.

### Affichage du numéro d'appel (CLIP<sup>1</sup>)



L'affichage du numéro d'appel est un service confort de votre opérateur. Veuillez lui demander de plus amples informations.

Si cette fonction est disponible sur votre ligne téléphonique, le numéro d'appel du correspondant vous sera affiché dès que le téléphone sonnera. Si votre correspondant a bloqué la transmission de son numéro, un message correspondant sera affiché. Le numéro d'appel ne peut pas être affiché et ne peut donc pas être sauvegardé dans la liste d'appels.

<sup>1</sup> **CLIP** : Calling Line Identification Presentation = Affichage du numéro d'appel d'un correspondant.

### Pause de numérotation

Dans le cas d'installations PABX, il faut composer auparavant un code réseau pour obtenir la tonalité. Sur quelques installations PABX plus anciennes, vous devez attendre quelques instants avant de pouvoir entendre la tonalité. Pour ces installations PABX, une pause de numérotation peut être insérée après le code réseau afin de pouvoir continuer à numéroter directement sans attendre la tonalité.

2 sec. 

Insérer une pause de numérotation

Après le code réseau, le numéro d'appel proprement dit est composé au bout d'un temps déterminé.



La pause peut également être enregistrée lors de la saisie de numéros d'appel dans le répertoire.

### Répondeur dans le réseau téléphonique





Le répondeur dans le réseau téléphonique est un service confort offert par de nombreux opérateurs. Si votre opérateur met à votre disposition un répondeur dans le réseau téléphonique, vous serez informé par une icône de l'arrivée de nouveaux messages (**VMWI**<sup>2</sup>). Vous ne pouvez disposer de cette fonction que si votre opérateur offre ce service confort. Veuillez lui demander de plus amples informations.

<sup>2</sup> **VMWI** : Visual Message Waiting Indication = Affichage optique de nouveaux messages.

## 7 Structure du menu

### Menu principal

Vous parvenez au menu principal en appuyant sur la touche . La page 35 vous indique comment vous déplacer dans le menu et effectuer des entrées.









RÉPONDEUR	ÉCOU. MESS.		
	EFF TS ANCIENS		
	ENR. MÉMO		
RÉG. RÉPONDEUR	RÉP. E/H FONC.	EN FONCTION / HORS FONCTION	
	DELAI ACTIV REP	2 / 4 / 6 / 8 / ÉCO. INTER.	
	REGLAGES ANN	ENREGISTRER	
		LECTURE	
ACCES DISTANCE	EN FONCTION / HORS FONCTION		
CODE D'ACCÈS	ANCIEN PIN <sup>1</sup> 	NOUVEAU PIN <sup>2</sup>	CONFIRMER PIN 
TON ALERTE MES	EN FONCTION / HORS FONCTION		
RÉPERTOIRE	RÉVISER		
	PROGRAMMER	ENTRER NUMÉRO 	ENTRER LE NOM 
HIST APPEL <sup>2</sup>	RÉVISER		
	EFFACER APPELS		
VOL. SONNERIE	HORS FONCTION, VOL. SONNERIE 1 - 6		

<sup>1</sup> Le code PIN est configuré en usine sur le "0000".

<sup>2</sup> L'affichage du numéro d'appel (**CLIP**<sup>3</sup>) est nécessaire pour l'affichage et la sauvegarde de numéros d'appels dans les listes d'appels. L'affichage du numéro d'appel est un service confort de votre opérateur. Veuillez lui demander de plus amples informations. Pour d'autres informations sur l'affichage du numéro d'appel  page 38.

<sup>3</sup> **CLIP**: Calling Line Identification Presentation = Affichage du numéro d'appel d'un correspondant.

## Structure du menu

TONAL.SONNERIE	TONAL.SONNERIE 1 - 10		
SONS	TONAL TOUCHES	EN FONCTION / HORS FONCTION	
	BATT FAIBLE	EN FONCTION / HORS FONCTION	
	HORS PORTEE	EN FONCTION / HORS FONCTION	
LANGUE	DEUTSCH / ENGLISH / FRANÇAIS / ITALIANO		
ENREG. COMBINE	CODE PIN: 	TENIR APPUYÉ RECHERCHE COMB.	
SUPPR. COMBINE	CODE PIN: 	COMBINÉX	SUPPRIMER?
MODE NUM	VOCALE		
	DECIMALE		
DUREE FLASH	COURT / MOYEN / LONG		
RÉG.DATE/HEURE	RÉGLAGE DATE 	RÉGLAGE HEURE 	
FORMAT HEURE	12-HR		
	24-HR		
FORMAT DATE	JJ/MM/YY/ MM/JJ/YY		
ANN. B. VOCALE	VOYANTS HORS FONCTION?		
PIN SYSTÈME	ANCIEN PIN <sup>1</sup> 	NOUVEAU PIN 	CONFIRMER PIN 
REINITIALISE	CODE PIN: 	REINITIALISER?	

<sup>1</sup> Le code PIN est configuré en usine sur le "0000".





## 8 Répertoire

Vous pouvez enregistrer 50 numéros d'appel et le nom y afférant dans votre répertoire.

- Les contacts du répertoire sont rangés par ordre alphabétique. Pour accéder directement au contact désiré, appuyez sur l'initiale correspondante.

### Saisir le nom









Des lettres sont gravées sur les touches numériques. En appuyant plusieurs fois sur la touche adéquate, vous pouvez saisir des lettres, des chiffres et des symboles.

	Entrer des espaces
	Effacer des caractères
	Entrer les caractères spéciaux













Pour saisir deux fois la même lettre, appuyez sur la touche correspondante. Attendez que le curseur soit passé derrière la lettre. Puis tapez la lettre une nouvelle fois.







### Créer des enregistrements du répertoire

	Ouvrir le menu principal	
		Sélectionner le répertoire et valider
		Sélectionner le sous-menu et valider
		Entrer le numéro (max. 30 chiffres) et valider
		Entrer le nom (max. 15 caractères) et sauvegarder

### Modifier des enregistrements du répertoire

	Ouvrir le menu principal	
		Sélectionner le répertoire et valider
		Sélectionner le sous-menu et valider
		Sélectionner un contact du répertoire et valider
		Modifier le numéro d'appel et valider
		Modifier le nom et valider

### Effacer des enregistrements du répertoire

	Ouvrir le menu principal	
		Sélectionner le répertoire et valider
		Sélectionner le sous-menu valider
		Sélectionner un contact du répertoire et valider

# Liste d'appels

## 9 Liste d'appels

50 numéros d'appel en tout sont enregistrés dans la liste d'appels.



L'affichage du numéro d'appel (**CLIP**<sup>1</sup>) est un service confort de votre opérateur. Votre téléphone affiche les numéros d'appel à l'écran si votre opérateur offre ce service. Veuillez lui demander de plus amples informations.

### Faire afficher les numéros d'appel issus de la liste d'appels



Ouvrir la liste d'appels et sélectionner un contact

### Rappeler des numéros d'appel entrés

Votre téléphone enregistre 50 appels dans une liste d'appels.

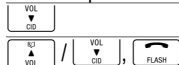

Ouvrir la liste d'appels  
Sélectionner le contact et établir la communication

### Enregistrer un numéro de la liste d'appel dans le répertoire

Vous pouvez sauvegarder un numéro d'appel dans le répertoire directement à partir de la liste d'appels.

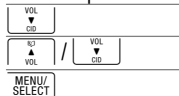

Ouvrir la liste d'appels  
Sélectionner le contact  
Ouvrir la fonction  
ÉDITER NUMÉRO, MENU/SELECT Modifier le numéro d'appel et valider  
ÉDITER LE NOM, MENU/SELECT Modifier le nom et valider

### Effacer des numéros individuels

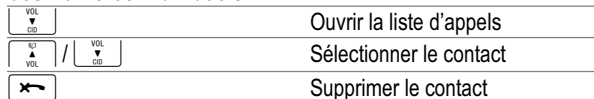

Ouvrir la liste d'appels  
Sélectionner le contact  
Supprimer le contact

### Effacer tous les numéros d'appel

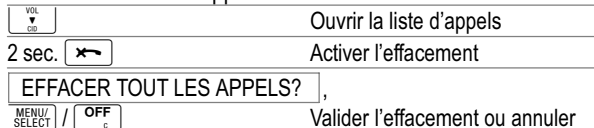

Ouvrir la liste d'appels  
Activer l'effacement  
EFFACER TOUT LES APPELS?  
Valider l'effacement ou annuler

<sup>1</sup> **CLIP** : Calling Line Identification Presentation = Affichage du numéro d'appel d'un correspondant.

## 10 Élargissement du système téléphonique



### Plusieurs combinés

Vous pouvez déclarer 5 combinés en tout sur votre base.

#### Déclaration de combinés

Avant de déclarer un combiné, vous devez mettre la base en mode de déclaration. Maintenez appuyée la touche de paging de la base jusqu'à ce qu'un signal sonore se fasse entendre. Maintenant, la base se trouve pendant quelques secondes en mode de déclaration. Continuez sur le combiné.

5 sec.  Démarrer le mode de déclaration

Déclarez maintenant le combiné  page 40. Pour cela, utilisez le code PIN actuellement paramétré  page 40.

Après la déclaration, un numéro d'appel interne est attribué au combiné.

#### Annulation de combinés



Chaque combiné peut s'annuler soi-même ou en annuler d'autres, déclarés sur cette base. Le message NON ENREGISTRÉ s'affiche sur l'écran du combiné annulé.

Les combinés s'annulent via le menu. La page 40 vous donnera la position dans le menu.

# Répondeur

## 11 Répondeur

### Manipulation sur le combiné

#### Ouvrir le menu de réglage

Vous effectuez les réglages du répondeur via votre combiné  
☞ page 39.

#### Activer / Désactiver le répondeur

Vous allumez / éteignez le répondeur via le combiné 8 Seite39.

#### Durée d'enregistrement maximale

La durée d'enregistrement maximum est de 13 minutes. Si la capacité de la mémoire est saturée et ne permet plus de recevoir de nouveaux messages, plus aucun appel ne sera enregistré.

#### Report de la prise d'appel

Vous pouvez sélectionner de 2 à 8 sonneries d'appel. En outre, vous pouvez utiliser le réglage ÉCO. INTER. pour la consultation préalable à distance exonérée de taxes. Cette consultation préalable à distance vous permet de constater gratuitement si de nouveaux messages se trouvent sur votre répondeur.

- S'il y a de nouveaux messages sur votre répondeur, votre appel sera pris dès la 2ème sonnerie.
- Si vous n'en avez pas, votre appel ne sera pris qu'après la 4ème sonnerie. Raccrochez avant la 4ème sonnerie. Vous ne paierez ainsi pas de redevances.

Autres informations relatives à la consultation à distance ☞ page 47

#### Intercepter un appel

Si le répondeur a déjà répondu à un appel, vous pouvez intercepter celui-ci. L'enregistrement du message est, dans ce cas, interrompu.



Prendre un appel

### Alarme en cas de messages enregistrés

Si un nouveau message ou un mémo a été enregistré, un signal sonore se fait entendre toutes les 10 secondes ☞ page 39.

### Écouter des annonces

		Ouvrir le menu principal
/	RÉPONDEUR	Sélectionner le répondeur et valider
		Sélectionner le sous-menu et valider
/	RÉG. RÉPONDEUR	Sélectionner le sous-menu et valider
		Sélectionner le sous-menu et valider
/	REGLAGES ANN	Sélectionner le sous-menu et valider
		Sélectionner le sous-menu et valider
/	LECTURE	Écouter l'annonce

### Enregistrer des annonces

		Ouvrir le menu principal
/	RÉPONDEUR	Sélectionner le répondeur et valider
		Sélectionner le sous-menu et valider
/	RÉG. RÉPONDEUR	Sélectionner le sous-menu et valider
		Sélectionner le sous-menu et valider
/	REGLAGES ANN	Sélectionner le sous-menu et valider
		Sélectionner le sous-menu et valider
/	ENREGISTRER	Enregistrer l'annonce et valider



JKL 5

Enregistrez maintenant le texte désiré en parlant clairement et distinctement dans le microphone de votre combiné. Quand vous aurez terminé, l'annonce sera reproduite à voix haute.

## Activer à nouveau le texte d'annonce standard

	Ouvrir le menu principal
/ <b>RÉPONDEUR</b> , 	Sélectionner le répondeur et valider
/ <b>RÉG. RÉPONDEUR</b> ,	Sélectionner le sous-menu et valider
/ <b>REGLAGES ANN</b> ,	Sélectionner le sous-menu et valider
/ <b>LECTURE</b> , 	Écouter l'annonce
	Effacer votre annonce personnelle pendant son écoute

## Fonctions des touches du menu de messages

Le tableau suivant vous donne une vue d'ensemble des fonctions individuelles de chaque touche dans le menu de messages.

Touche	Fonctions
/	Régler le volume
<b>DEF 3</b>	Supprimer le message pendant la reproduction
<b>GHI 4</b>	Faire répéter un message
<b>2 x GHI 4</b>	Écouter le message précédent
<b>JKL 5</b>	L'écoute du message est arrêtée
<b>MNO 6</b>	Écouter le message suivant
<b>OFF c</b>	Terminer l'écoute

## Effacer tous les anciens messages

Tous les messages sont effacés.

	Ouvrir le menu principal
/ <b>RÉPONDEUR</b> , 	Sélectionner le répondeur et valider
/ <b>EFF TS ANCIENS</b> ,	Activer l'effacement
<b>EFFACER TOUT</b>	Valider l'effacement ou
<b>ANCIENS MESS?</b> / <b>OFF c</b>	annuler



Les messages effacés ne peuvent pas être restaurés !

## Enregistrer un mémo

Un mémo est une information qui peut être écoutée comme un message entré.

	Ouvrir le menu principal
/ <b>RÉPONDEUR</b> , 	Sélectionner le répondeur et valider
/ <b>ENR. MÉMO</b> , 	Sélectionner le sous-menu et valider
<b>JKL 5</b>	Enregistrer le mémo et valider

# Répondeur

## Manipulations sur la base

### Brancher / Débrancher le répondeur

	Brancher / débrancher le répondeur
---	------------------------------------

### Régler le volume sonore

Vous pouvez régler le volume sonore sur 8 sensibilités.

	Démarrer l'écoute
---	-------------------

 ou 	Régler le volume (L1-L8)
--	--------------------------

### Écouter / Effacer les messages enregistrés

#### Écouter les messages

Les messages enregistrés sont reproduits dans l'ordre dans lequel ils sont entrés.

	Écouter / arrêter les messages
---	--------------------------------

	Répéter le message
---	--------------------

2x 

	Message suivant
---	-----------------

#### Effacer un message

	Écouter le message à effacer
---	------------------------------

	Effacer pendant l'écoute
---	--------------------------

#### Effacer tous les anciens messages

 Les messages effacés ne peuvent pas être restaurés !

Tous les anciens messages s'effacent.

	Démarrer l'écoute
---	-------------------

 	Effacer tous les anciens messages
---	-----------------------------------

## Écran du répondeur

L'écran du répondeur indique l'état de l'appareil.

--	Répondeur débranché
0-59	Répondeur branché, nombre de messages enregistrés
0-59 LED clignotante	Répondeur branché, nombre de nouveaux messages
r-ff	Accès via un combiné ou la consultation à distance
FF	Mémoire pleine

## Consultation à distance



Vous pouvez appeler votre répondeur pour écouter des messages et vous servir d'autres fonctions à condition que votre téléphone soit équipé de la fonctionnalité de numérotation par tonalité.

### Code PIN pour la consultation à distance

Le code PIN est réglé à l'usine sur "0000". Il est recommandé de modifier le code PIN usine. Pour modifier le code PIN ➞ page 39

### Démarrer la consultation à distance

 Composer le numéro d'appel personnel



 ,  Saisir le code PIN pendant l'annonce

Vous avez maintenant la possibilité d'opérer d'autres fonctions ➞ Tableau de fonctions des touches de la consultation à distance.

### Brancher la consultation à distance du répondeur

 Composer le numéro d'appel personnel

 Si vous avez oublié de brancher votre répondeur, votre appel ne sera réceptionné qu'au bout de 10 sonneries.

 ,  Saisir le code PIN pendant l'annonce

 Activer le répondeur









Vous avez maintenant la possibilité de vous servir d'autres fonctions.

## Fonctions des touches de la consultation à distance



La consultation à distance est automatiquement interrompue si vous n'effectuez pas de saisie dans les 30 secondes.

Le tableau suivant vous donne une vue d'ensemble des fonctions de chaque touche.

Touche	Fonctions quand <u>aucun message n'est reproduit</u>	Fonctions quand des messages sont reproduits
		Supprimer le message pendant l'écoute
2 x 	Effacer tous les anciens messages	
		Faire répéter le message en cours
2 x 		Écouter le message précédent
	Écouter des messages	Arrêter l'écoute
		Écouter le message suivant
	Brancher le répondeur	
	Débrancher le répondeur	
	Terminer la consultation à distance	Terminer la consultation à distance

# En cas de problèmes

## 12 En cas de problèmes

### Hotline de service

Si vous avez des problèmes avec votre téléphone, observez d'abord les remarques suivantes. S'il s'agit de problèmes techniques, vous pouvez vous adresser à notre hotline de service en Suisse au numéro de tel. 0900 00 1675 (frais Swisscom à la date d'impression de ce manuel : CHF 2.60/min). Si vous jouissez de droits de garantie, adressez-vous à votre revendeur. La durée de la garantie est de 2 ans.

### Questions et réponses

Questions	Réponses
Pas de connexion possible avec la base	<ul style="list-style-type: none"><li>- Contrôlez que vous vous êtes déclaré sur la base avec le code PIN correct ➤ page 40.</li></ul>
Pas de communication téléphonique possible	<ul style="list-style-type: none"><li>- Le téléphone n'est pas raccordé correctement ou est en dérangement. N'utilisez que le câble de raccordement téléphonique fourni avec l'appareil.</li><li>- Testez avec un autre téléphone si votre raccordement téléphonique fonctionne.</li><li>- Le bloc secteur n'est pas branché ou il y a une panne totale de courant.</li><li>- Le pack de piles rechargeables est vide ou défectueux.</li><li>- Vous vous êtes trop éloigné de la base.</li><li>- Réglage erroné du système de numérotation ➤ page 40.</li></ul>

La liaison est hâchée, s'interrompt	<ul style="list-style-type: none"><li>- Vous vous êtes trop éloigné de la base.</li><li>- Mauvais lieu d'installation de la base.</li></ul>
Le système ne réagit plus	<ul style="list-style-type: none"><li>- Remettez toutes les fonctions en configuration usine via "REINITIALISE" ➤ page 40.</li><li>- Retirez le bloc secteur de la prise de courant pendant un court instant.</li></ul>
Le pack de piles rechargeables se vide très rapidement	<ul style="list-style-type: none"><li>- Le pack de piles rechargeables est vide ou défectueux.</li><li>- Placez le combiné correctement sur la base. Nettoyez les surfaces de contact du combiné et de la base avec un chiffon doux et sec.</li><li>- Posez le combiné sur la base pendant 16 heures.</li></ul>
L'affichage du numéro d'appel (CLIP <sup>1</sup> ) ne fonctionne pas	<ul style="list-style-type: none"><li>- L'affichage du numéro d'appel est un service confort de votre opérateur. Veuillez lui demander de plus amples informations.</li><li>- Le correspondant a bloqué la transmission de son numéro d'appel.</li></ul>

<sup>1</sup> **CLIP** : Calling Line Identification Presentation = Affichage du numéro d'appel d'un correspondant.



Le répondeur ne prend pas de messages

- Assurez-vous que le répondeur est branché.
- Contrôlez si la mémoire du répondeur est pleine. Effacez le cas échéant des messages se trouvant dans la mémoire  page 45.

Vous ne pouvez pas consulter à distance

- Contrôlez si vous utilisez le code de sécurité correct pour la consultation à distance  Page 39.
- Le téléphone que vous utilisez pour la consultation à distance doit être réglé sur la numérotation par tonalité.

# Caractéristiques techniques

## 13 Caractéristiques techniques

### Caractéristiques techniques

Caractéristique	Valeur
Standard	<b>DECT<sup>1</sup></b>
Alimentation en courant (base)	Entrée : 100-240 V, 50/60 Hz Sortie : 6 V, 600 mA
Alimentation en courant (chargeur)	Entrée : 100-240 V, 50/60 Hz Sortie : 6 V, 300 mA
Portée	À l'extérieur : env. 300 m À l'intérieur : env. 50 m
Autonomie en veille	Jusqu'à 100 h
Durée max. de communication	Jusqu'à 8 h
Pack de piles rechargeables	NiMH 2,4 V 500 mAh
MODE NUM	VOCALE DECIMALE
DUREE FLASH	100 ms, 300 ms, 600 ms

### Configurations usine

#### Combiné

Les paramètres usine sont rétablis via le menu.  
La page 40 vous donnera la position dans le menu.

VOL. SONNERIE	VOL. SONNERIE3
TONAL.SONNERIE	TONAL.SONNERIE 2
TONAL TOUCHES	EN FONCTION
BATT FAIBLE	EN FONCTION
HORS PORTEE	EN FONCTION
LANGUE	DEUTSCH
FORMAT HEURE	24-HR
FORMAT DATE	JJ/MM/YY

#### Base

Les paramètres usine sont rétablis via le menu.  
La page 40 vous donnera la position dans le menu.

VOL. SONNERIE	3
MODE NUM	VOCALE
DUREE FLASH	COURT
PIN SYSTÈME	0000

<sup>1</sup> **DECT**: Digital Enhanced Cordless Telecommunication = Standard pour les téléphones sans fil.

### Répondeur

RÉP. E/H FONC.	EN FONCTION
DELAI ACTIV REP	6
TON ALERTE MES	EN FONCTION
CODE D'ACCÈS	0000

### Déclaration de conformité

Cet appareil répond aux exigences des directives de l'union européenne (UE) : 1999/5/CE : Directive sur les installations de radio et de télécommunication et la reconnaissance réciproque de leur conformité. La conformité à la directive ci-dessus est confirmée sur l'appareil par le symbole CE. Pour obtenir la déclaration de conformité intégrale, veuillez vous servir du téléchargement gratuit de notre site Internet [www.switel.com](http://www.switel.com).



# Remarques d'entretien / Garantie

## 14 Remarques d'entretien / Garantie

### Remarques d'entretien

- Nettoyez les surfaces du boîtier avec un chiffon doux et non pelucheux.
- N'utilisez pas de produits d'entretien ou de solvants.

### Garantie

Les appareils SWITEL sont fabriqués et contrôlés selon les procédés les plus modernes. Des matériaux sélectionnés et des technologies de pointe garantissent un fonctionnement irréprochable et une longue durée de vie. La garantie ne rentre pas en jeu si l'exploitant du réseau téléphonique ou une installation PABX éventuellement intercalée est responsable du dysfonctionnement de l'appareil. La garantie ne s'applique pas aux batteries, batteries rechargeables ou packs de batteries rechargeables utilisés dans les produits. La durée de la garantie est de 24 mois à partir de la date d'achat.

Pendant la période de garantie, tous les défauts dus à des vices de matériel ou de fabrication seront éliminés gratuitement. Le droit à la garantie expire en cas d'intervention de l'acheteur ou de tiers. Les dommages provenant d'un maniement ou d'une manipulation incorrects, d'une usure naturelle, d'une mauvaise mise en place ou d'une mauvaise conservation, d'un raccordement ou d'une installation incorrects ainsi que d'un cas de force majeure ou autres influences extérieures sont exclus de la garantie. En cas de réclamations, nous nous réservons le droit de réparer, de remplacer les pièces défectueuses ou d'échanger l'appareil. Les composants remplacés ou les appareils échangés deviennent notre propriété. Les demandes de dommages et intérêts sont exclues tant qu'elles ne reposent pas sur l'intention ou une négligence grossière du fabricant.

Si votre appareil devait malgré tout présenter une défectuosité pendant la période de garantie, veuillez vous adresser, muni de votre reçu, exclusivement au magasin où vous avez acheté votre appareil SWITEL. Vous ne pouvez faire valoir vos droits à la garantie selon ces dispositions qu'exclusivement auprès de votre revendeur. Deux ans après l'achat et la remise de nos produits, il n'est plus possible de faire valoir les droits en matière de garantie.

## 15 Index

**A**

Affichage du numéro d'appel, 38, 42  
 Alarme, 44  
 Allumer, 37  
 Annonce, 44  
 Annonces, 44  
 Annulation, 43  
 Appeler, 36

**B**

Base, 31, 33  
 Brancher la consultation à distance, 47

**C**

Caractéristiques techniques, 50  
 Chercher le combiné, 37  
 CLIP, 38  
 Code PIN, 47  
 Combiné, 43  
 Communications internes, 36  
 Composer des numéros, 36  
 Conférences téléphoniques, 37  
 Configurations usine, 50  
 Consignes de sécurité, 30  
 Consultation à distance, 47  
 Contenu du coffret, 31

**D**

Date, 32  
 Déclaration, 43  
 Déclaration de conformité, 51  
 Durée d'enregistrement maximale, 44  
 Durée de la communication, 37

**E**

Économiseur de taxes, 44  
 Écouter, 44, 46  
 Écran, 34, 46  
 Effacer, 45, 46  
 Effacer des messages, 46  
 Élargissement, 43  
 Éléments de manipulation, 33  
 Emploi, 34  
 Enregistrement, 44  
 Enregistrements du répertoire, 35, 41  
 Enregistrer un mémo, 45  
 Éteindre, 37

**F**

Fonction R, 38  
 Fonctions des touches, 45, 47

**G**

Garantie, 52

**H**

Heure, 32  
 Hotline de service, 48

**I**

Icônes, 34  
 Icônes à l'écran, 34  
 Installations PABX, 38  
 Interception d'appel, 44  
 Intercommunication, 37

**L**

Liste d'appels, 42

**M**

Manipulation sur le combiné, 44  
 Manipulations sur la base, 46  
 Menu de réglage, 44  
 Menu principal, 39  
 Messages, 46  
 Mettre en place le pack de piles rechargeables, 32  
 Mise du micro sur muet, 37  
 Mise en service, 31  
 Mise sur muet, 37  
 Mode ÉCO, 32  
 Mode économie d'énergie, 35  
 Mode mains-libres, 37  
 Mode veille, 35

**N**

Niveau de chargement des piles, 32  
 Notations, 34

**P**

Paging, 37  
 Pause de numérotation, 38  
 Prise d'appel, 36  
 Problèmes, 48

**Q**

Questions et réponses, 48

**R**

Raccrocher, 36  
 Rappel, 36, 42  
 Rechargement, 32  
 Réduction du rayonnement, 32  
 Remarques d'entretien, 52  
 Répertoire, 36, 41  
 Répétition des derniers numéros, 36  
 Répondeur, 44  
 Répondeur dans le réseau téléphonique, 38  
 Report, 44

**S**

Saisie de nom, 41  
 Saisie de texte, 41  
 Sauvegarder, 35, 41, 42  
 Services confort, 38  
 Structure du menu, 39  
 Suppression d'erreurs, 48

**T**

Téléphoner, 36  
 Terminer la communication, 36  
 Transfert, 36  
 Transfert de communication, 36

**V**

Va-et-vient, 37  
 VMWI, 38  
 Volume sonore, 46  
 Volume sonore de l'écouteur, 37

## Notes

---

1	Indicazioni di sicurezza . . . . .	56
2	Mettere in funzione il telefono . . . . .	57
3	Elementi di comando . . . . .	59
4	Informazioni introduttive . . . . .	60
5	Compiere telefonate . . . . .	62
6	Impianti telefonici interni / Servizi aggiuntivi . . . . .	64
7	Struttura del menu . . . . .	65
8	Rubrica telefonica . . . . .	67
9	Elenco chiamate . . . . .	68
10	Ampliamento del sistema telefonico . .	69
11	Segreteria telefonica . . . . .	70
12	In presenza di problemi . . . . .	74
13	Specifiche tecniche . . . . .	76
14	Consigli per la cura / Garanzia . . . . .	78
15	Indice alfabetico . . . . .	79

# Indicazioni di sicurezza

## 1 Indicazioni di sicurezza

Leggere attentamente le presenti istruzioni per l'uso.

### Impiego conforme agli usi previsti

Il presente telefono consente di svolgere telefonate all'interno di una rete telefonica. Qualsiasi altro impiego è considerato come non conforme agli usi previsti. Non sono consentite modifiche o trasformazioni non autorizzate. Non aprire per nessuna ragione l'apparecchio autonomamente, né compiere riparazioni di propria iniziativa.

### Luogo di installazione

Evitare un'esposizione a fumo, polvere, vibrazioni, sostanze chimiche, umidità, calore e raggi solari diretti.

Non utilizzare l'unità portatile in aree esposte al rischio di deflagrazione.

### Alimentatore di rete



**Attenzione:** Utilizzare solo l'alimentatore a spina fornito in dotazione visto che altri alimentatori di rete potrebbero addirittura danneggiare il telefono. Non ostacolare il libero accesso all'alimentatore a spina con mobili o altri oggetti simili.

### Accumulatore ricaricabile



**Attenzione:** Non gettare l'accumulatore ricaricabile nel fuoco. Utilizzare solo accumulatori dello stesso tipo. Osservare la corretta polarità! Pericolo di esplosione durante il caricamento dell'accumulatore in caso di errata polarità.

### Caduta di tensione

In caso di caduta di tensione non è possibile compiere chiamate con questo telefono. Si consiglia di ricorrere in caso di emergenza ad un telefono con filo in grado di funzionare anche senza alimentazione elettrica esterna.

### Compatibilità con apparecchi acustici

Il telefono è compatibile con il maggior numero di apparecchi acustici presenti sul mercato. Ciò nonostante non è possibile garantire un perfetto funzionamento con qualsiasi tipo di apparecchio acustico.

## Apparecchiature mediche



**Attenzione:** Non utilizzare il telefono in prossimità di apparecchiature mediche. Non è infatti possibile escludere il rischio di possibili interferenze.

Telefoni **DECT**<sup>1</sup> possono causare un fastidioso ronzio in apparecchi acustici.

## Smaltimento

Procedere allo smaltimento dell'apparecchio esaurito consegnandolo presso uno dei punti di raccolta istituiti dalla propria società di smaltimento rifiuti comunale (ad es. centro di riciclo materiali). Secondo quanto previsto dalla legge sugli apparecchi elettrici ed elettronici, i proprietari di apparecchi esauriti sono per legge tenuti alla consegna di tutti gli **apparecchi elettrici ed elettronici** presso un centro di rilievo rifiuti in raccolta differenziata. Il simbolo riportato qui a lato indica che non è assolutamente consentito smaltire l'apparecchio assieme ai normali rifiuti domestici!



**Accumulatori e batterie possono provocare danni alla salute e all'ambiente!**



Non aprire, danneggiare, ingerire o disperdere nell'ambiente accumulatori e batterie. Questi possono contenere metalli pesanti nocivi e dannosi per l'ambiente. Per legge sussiste l'obbligo di consegnare accumulatori e batterie presso i rivenditori di batterie utilizzando gli appositi contenitori di raccolta e provvedendo in tal modo al corretto smaltimento. Lo smaltimento è gratuito. I simboli indicano che non è assolutamente consentito gettare accumulatori e batterie nei rifiuti domestici, consegnandoli ai fini dello smaltimento nei rispettivi punti di raccolta.

Smaltire **confezioni ed imballaggi** in base a quanto indicato dalle norme in vigore a livello locale.

<sup>1</sup> **DECT:** Digital Enhanced Cordless Telecommunication = Standard per telefoni senza cavo.



## 2 Mettere in funzione il telefono

### Indicazioni di sicurezza



**Attenzione:** Prima della messa in funzione, leggere attentamente le indicazioni di sicurezza riportate al capitolo 1.

### Verificare il contenuto della confezione

La confezione contiene:

Contenuto	Modello DFT 137X			
	DFT 1371	DFT 1372 <sup>1</sup>	DFT 1373 <sup>1</sup>	DFT 1374 <sup>1</sup>
Stazione base con alimentatore di rete	1	1	1	1
Stazione di carica con alimentatore di rete	-	1	2	3
Unità portatile	1	2	3	4
Cavo di collegamento telefonico	1	1	1	1
Accumulatore ricaricabile	1	2	3	4
Istruzioni per l'uso	1	1	1	1

<sup>1</sup> Per ulteriori informazioni riguardo la disponibilità di questo set telefonico si prega di visitare il sito [www.switel.com](http://www.switel.com).

### Collegare l'unità base



**Attenzione:** Montare l'unità base con una distanza minima di 1 m da altri apparecchi elettronici in modo da evitare interferenze reciproche.

Procedere al collegamento dell'unità base seguendo quanto raffigurato nella figura. Utilizzare per motivi di sicurezza solo l'alimentatore di rete oltre al cavo di collegamento telefonico fornito in dotazione.

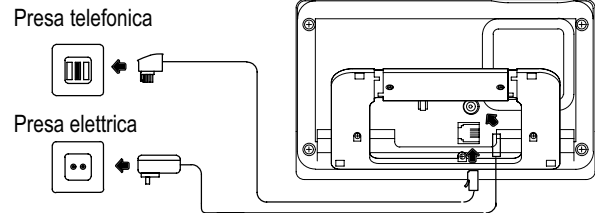

### Avvertimento importante

La stazione base del vostro telefono è dotata di un circuito di alimentazione rete ad efficienza energetica SSA-5AP-09EU060060 (Input 100~240 V<sub>AC</sub>, Output 6 V<sub>DC</sub>, 600 mA). Il carico nullo è pari a circa 0,15 W. L'efficienza media è pari a circa il 65%.

La potenza assorbita dalla stazione base ammonta a:

- in servizio (stand-by/conversazione): ca. 1,5 W
- durante la carica dell'unità mobile: ca. 2,5 W

La(e) stazione(i) di carica fornita(e) con un set telefonico è/sono dotata(e) di un circuito di alimentazione rete ad efficienza energetica S002CV0600030 (Input 100~240 V<sub>AC</sub>, Output 6 V<sub>DC</sub>, 300 mA). Il carico nullo è pari a circa 0,15 W. L'efficienza media è pari a circa il 60%. La potenza assorbita dalla stazione di carica ammonta a:

- senza unità mobile: ca. 0,15 W
- durante la carica dell'unità mobile: ca. 1,2 W

## Mettere in funzione il telefono

### Inserire l'accumulatore ricaricabile

Spingere il coperchio del vano accumulatore in basso, quindi rimuoverlo. Innestare il connettore dell'accumulatore ricaricabile nella presa presente all'interno del vano accumulatore. Inserire l'accumulatore ricaricabile nell'apposito vano. Utilizzare esclusivamente l'accumulatore ricaricabile fornito. Fare attenzione a non incastrare il cavo. Riposizionare il coperchio sul vano accumulatore spingendolo verso sopra fino a quando scatta in posizione.

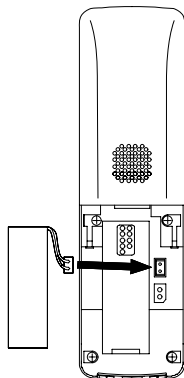

### Caricare l'accumulatore ricaricabile

 Riporre l'unità portatile in sede di prima messa in funzione per **minimo** 16 ore nell'unità base / stazione di carica.

Con unità portatile posizionata correttamente nella stazione base/stazione di carica, la spia di controllo dello stato di carica risulta accesa. L'unità portatile si surriscalda durante il processo di carica. Questo è un fenomeno normale e non pericoloso. Evitare di caricare l'unità portatile con dispositivi di carica differenti o estranei. Lo **stato di carica** attuale è visualizzato sul display:



Carico



Carico a 2/3



Debole



Scarico

### Impostare data e ora dell'unità portatile

Una voce di menu consente di impostare data e ora. A pagina 66 è indicata la posizione da scorrere nel menu.

### Impianti telefonici interni

A pagina 64 sono riportate ulteriori informazioni nel caso in cui si volesse collegare il telefono ad un impianto telefonico interno.

### Riduzione delle radiazioni (modalità ECO)











In modalità di conversazione le radiazioni sono ridotte in base alla distanza dell'unità portatile dalla base.



## 3 Elementi di comando







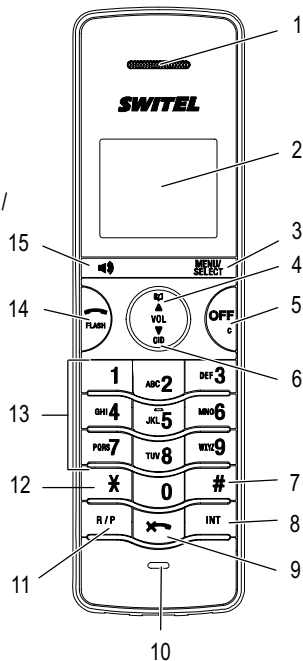



I tasti del telefono riportati nel presente manuale d'istruzioni sono raffigurati sotto forma di simboli uniformi all'interno di un riquadro. Sono possibili lievi scostamenti dei simboli dei tasti sul telefono rispetto ai simboli qui raffigurati.

### Unità portatile

- 1 Ricevitore
- 2 Display
- 3 Tasto 
- 4 Navigazione in alto / Aumento volume / Rubrica 
- 5 Tasto di riaggancio / Indietro / Cancella / Spegnimento 
- 6 Navigazione in basso / Riduzione volume / Elenco chiamate 
- 7 Tasto 
- 8 Chiamate interne
- 9 Silenziamento del microfono / Cancella 
- 10 Microfono
- 11 Ripetizione di chiamata / Inserimento pausa di selezione 
- 12 Tasto 
- 13 Tasti numerici
- 14 Tasto conversazione / Tasto R 
- 15 Funzione vivavoce 



### Stazione base (segreteria telefonica)

- 1 LED: visualizzazione di chiamata 
- 2 Cerca l'unità portatile (paging) 
- 3 Segreteria telefonica ON / OFF 
- 4 Cancella 
- 5 Display
- 6 LED: segnalazione dello stato di carica 
- 7 Volume + 
- 8 Volume - 
- 9 Messaggio successivo 
- 10 Riproduzione/Stop 
- 11 Ripetizione messaggio / Messaggio precedente 
- 12 Altoparlante
- 13 Contatti di carica

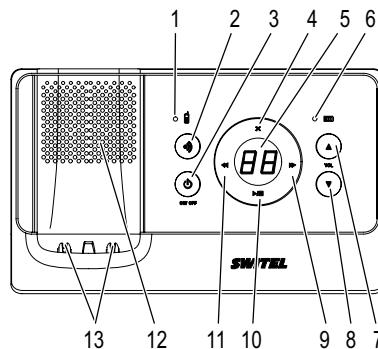











# Informazioni introduttive















## 4 Informazioni introduttive

In questo capitolo sono riportate le principali informazioni riguardo l'uso delle presenti istruzioni e del telefono.

### Modi di rappresentazione nelle istruzioni per l'uso

Rappresentazione	Descrizione
	Rappresentazione dei tasti
	Premere brevemente il tasto raffigurato
3 sec. 	Premere il tasto raffigurato per 3 secondi
tenere premuto 	Tenere premuto il tasto raffigurato
rilasciare 	Rilasciare il tasto raffigurato
	Inserire numeri o lettere
	Unità portatile squilla
	Stazione base squilla
	Estrarre l'unità portatile dalla stazione base
	Riporre l'unità portatile nella stazione base
RICEVITORE	Rappresentazione di testi sul display
	Rappresentazione di simboli sul display

### Simboli e testi sul display dell'unità portatile

Simbolo	Descrizione
	Indicazione dello stato di carica dell'accumulatore.
GG/MM	Visualizzazione della data  pagina 66.
hh:mm	Visualizzazione dell'ora  pagina 66.
	Nuova voce nell'elenco chiamate  pagina 68.
	Attivata la funzione vivavoce  pagina 63.
	Segreteria telefonica integrata nella rete telefonica. <b>VMWI</b> <sup>1</sup> - Servizio aggiuntivo del proprio gestore di rete telefonica  pagina 64.
	Microfono in modalità silenziamento  pagina 63.
	Squillo di chiamata disinserito  pagina 65.
	Segreteria telefonica inserita  pagina 70.
	Presenza di nuovi messaggi sulla segreteria telefonica.

<sup>1</sup> **VMWI**: Visual Message Waiting Indication = Segnalazione ottica di nuovi messaggi.

## Modalità di stand-by

In tutte le descrizioni del presente manuale di istruzioni si considera l'unità portatile in modalità di stand-by. Per passare alla modalità di stand-by, premere se occorre ripetutamente il tasto .













## Modalità di risparmio energetico

Dopo un determinato periodo di tempo in modalità di stand-by, l'unità portatile passa alla modalità di risparmio energetico. A questo punto, tasti e display non risultano più illuminati.

## Navigazione nel menu

I differenti menu consentono di raggiungere tutte le funzioni del telefono.

Il percorso da seguire per giungere alla funzione desiderata è indicato dalla struttura di menu  pagina 65.











	Aprire il menu principale
 o 	Selezionare il sottomenu richiesto
	Aprire il sottomenu
 o 	Selezionare la funzione richiesta
	Aprire la funzione
 o 	Selezionare l'impostazione richiesta
	La tastiera consente di inserire numeri o lettere
	Confermare le immissioni
	Indietro di un livello
	Interrompere le procedure di programmazione e memorizzazione e tornare indietro alla modalità di stand-by



Ogni singolo processo si interrompe automaticamente se entro 30 secondi non si procede con un'immissione.

## Creare voci della rubrica telefonica - Esempio

La navigazione nei menu e la procedura da seguire per compiere impostazioni è indicata a titolo esemplificativo in **Creare voci della rubrica telefonica**. Si consiglia di seguire quanto riportato nell'esempio per tutte le impostazioni che si desiderano compiere.

	Aprire il menu principale
 /  <b>RUBRICA</b> , 	Selezionare la rubrica telefonica e confermare
 /  <b>MEMORIZZAZIONI</b> , 	Selezionare il sottomenu e confermare
<b>INSERIRE NUM</b> ,  	Immettere un numero di chiamata (max. 30 cifre) e confermare
<b>INSERIRE NOME</b> ,  	Immettere un nome (max. 15 segni) e salvare



# Compiere telefonate

## 5 Compiere telefonate

### Accettare la chiamata

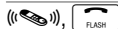

Ricevere la chiamata

### Concludere la chiamata



Concludere la chiamata

### Compiere telefonate



Immettere il numero di chiamata (max. 30 cifre)



In caso di immissione errata cancellare l'ultima cifra



Selezionare il numero di chiamata



È altresì possibile premere il tasto di conversazione e ottenere il segnale di linea libera. Le cifre immesse per la composizione del numero di chiamata desiderato sono immediatamente selezionate. Nel corso di una simile chiamata non è possibile eseguire la correzione di singole cifre che compongono il numero di chiamata.

### Ripetizione di chiamata

Il telefono memorizza i 5 ultimi numeri di chiamata selezionati all'interno di un elenco di ripetizione di chiamata.



Aprire l'elenco di ripetizione di chiamata

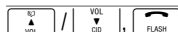

Selezionare la voce e instaurare un collegamento

### Richiamare un interlocutore perso

Il telefono memorizza 50 chiamate nell'elenco chiamate.



Aprire l'elenco chiamate

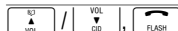

Selezionare la voce e instaurare un collegamento

### Selezionare numeri di chiamata dalla rubrica telefonica

Per fare questo è necessario aver precedentemente memorizzato dei numeri nella rubrica telefonica pagina 61 e 67.



Aprire la rubrica telefonica



Selezionare la voce e instaurare un collegamento

### Compiere chiamate interne<sup>1</sup>

#### Condurre chiamate interne

Per condurre telefonate interne gratuite bisogna aver registrato due o più unità portatili (UP1, UP2, ...) presso la stazione base.

UP1: INT, ad es. ABC 2

Selezionare il numero di chiamata dell'unità portatile desiderata

UP2: FLASH

Accettare la chiamata sull'altra unità portatile

UP1 / UP2: OFF c

Concludere la telefonata interna

#### Trasferire internamente chiamate esterne

UP1: INT, ad es. ABC 2

Selezionare con chiamata esterna in corso un numero di chiamata interno

UP2: FLASH

Accettare la chiamata sull'altra unità portatile

UP1: OFF c

Trasferire la chiamata





Se l'unità portatile chiamata non risponde, la telefonata esterna può essere di nuovo ripresa premendo il tasto



<sup>1</sup> Per compiere telefonate interne sono necessarie minimo due unità portatili "Verificare il contenuto della confezione" a pagina 57.

## Riscontro / Chiamata in attesa

Durante lo svolgimento di una chiamata esterna è possibile chiamare un'altra unità portatile allo scopo di consultarsi o eseguire un riscontro. Mentre è in corso la conversazione con l'interlocutore interno, la chiamata esterna è trattenuta. La procedura può essere ripetuta a piacere.



UP1: , ad es.  Selezionare con chiamata esterna in corso un numero di chiamata interno

UP2:  Accettare la chiamata sull'altra unità portatile

UP1:  Passare ad un altro partner di chiamata

## Condurre chiamate a conferenza

Questa funzione consente di condurre una conferenza con una chiamata esterna ed un altro interlocutore interno.

UP1: , ad es.  Selezionare con chiamata esterna in corso un numero di chiamata interno

UP2:  Accettare la chiamata sull'altra unità portatile

UP1: tenere premuto  Avviare la conferenza

UP1 / UP2:  Concludere la conferenza

## Impostare il volume del ricevitore

Il volume è regolabile durante lo svolgimento di una chiamata in 5 livelli.

 o  Selezionare il volume richiesto

## Funzione vivavoce

Utilizzare questa funzione per ascoltare il partner di chiamata attraverso l'altoparlante.

 Attivare la funzione vivavoce

 Disattivare la funzione vivavoce

## Visualizzare la durata di conversazione

Durante lo svolgimento di una chiamata, la durata della telefonata è visualizzata in ore, minuti e secondi.

## Silenziamento del microfono nell'unità portatile

È possibile attivare e disattivare il microfono dell'unità portatile con chiamata telefonica in corso.

 Disattivare il microfono (silenziamento)

 Attivare il microfono

## Ricerca dell'unità portatile (funzione di paging)

Avendo perso d'occhio la propria unità portatile è possibile ritrovarla facilmente grazie all'emissione di un tono di ricerca.

  Avviare il tono di ricerca

 o  Concludere il tono di ricerca

## Attivare e disattivare l'unità portatile

Allo scopo di non sollecitare troppo l'accumulatore ricaricabile è possibile spegnere l'unità portatile.

1 sec. ,  Spegnere l'unità portatile

5 sec.  Accendere l'unità portatile



# Impianti telefonici interni / Servizi aggiuntivi

## 6 Impianti telefonici interni / Servizi aggiuntivi

### Funzione R in impianti telefonici interni

Avendo collegato il telefono ad un impianto telefonico interno, il tasto  consente di accedere a tutte le altre funzioni disponibili, come ad es. trasferimento di chiamata e funzione di richiamata automatica. Si prega di consultare le istruzioni per l'uso del proprio impianto telefonico interno per individuare la durata flash da impostare al fine di poter usufruire di queste funzioni. Il rivenditore autorizzato è in grado di indicare se il telefono acquistato funzionerà senza alcun problema nel proprio impianto telefonico interno. La durata flash è impostata tramite menu. A pagina 66 è indicata la posizione da scorrere nel menu.

### Funzione R e servizi aggiuntivi

Il telefono supporta servizi aggiuntivi messi a disposizione dal proprio gestore di rete telefonica come ad es. le funzioni di chiamata in attesa, avviso di chiamata e chiamata a conferenza. Il tasto  consente di accedere a questi servizi aggiuntivi. Si prega di consultare il proprio gestore di rete telefonica per ottenere informazioni sulla durata flash necessaria all'utilizzo dei servizi aggiuntivi. Rivolgersi al proprio gestore di rete telefonica per ottenere l'abilitazione ai servizi aggiuntivi. La durata flash è impostata tramite menu. A pagina 66 è indicata la posizione da scorrere nel menu.

### Visualizzazione del numero di chiamata (CLIP<sup>1</sup>)



La visualizzazione del numero di chiamata è un servizio aggiuntivo offerto dal proprio gestore di rete telefonica. Si consiglia di rivolgersi al proprio gestore di rete telefonica per ricevere ulteriori informazioni a riguardo.

A condizione che il collegamento telefonico disponga di questa funzione, l'apparecchio visualizza il numero telefonico del chiamante non appena il telefono squilla. Nel caso in cui il chiamante abbia soprappreso la trasmissione del proprio numero di chiamata, appare un'apposita indicazione. Se il numero di chiamata non è visualizzabile, questo non sarà memorizzato nell'elenco chiamate.

### Pausa di selezione

In presenza di impianti telefonici interni è necessario preselezionare un numero di accesso alla rete esterna per ottenere un segnale di linea libera prima di poter compiere una telefonata. Alcuni impianti telefonici interni di vecchia data richiedono del tempo prima di trasmettere il segnale di libero. Per questi impianti telefonici interni è possibile inserire una pausa di selezione dopo il numero di accesso alla linea esterna in modo da poter proseguire con la selezione del numero senza dover attendere il segnale di libero.

2 sec. 

Inserire una pausa di selezione

Dopo il numero di accesso alla rete esterna si procede, trascorso un determinato intervallo di tempo, con la selezione del numero di chiamata vero e proprio.



La pausa di selezione è memorizzabile anche in sede di immissione di numeri di chiamata nella rubrica telefonica.

### Segreteria telefonica integrata nella rete telefonica

Sono numerosi i gestori di rete telefonica che offrono come servizio aggiuntivo una segreteria telefonica integrata nella stessa rete. Se il proprio gestore di rete telefonica mette a disposizione una segreteria telefonica all'interno della rete telefonica, un simbolo informa sulla presenza di nuovi messaggi (VMWI<sup>2</sup>). Questa funzione è disponibile solo nel caso di abilitazione al servizio da parte del gestore di rete telefonica. Per maggiori dettagli a riguardo, rivolgersi al proprio gestore di rete telefonica.

<sup>1</sup> **CLIP**: Calling Line Identification Presentation = Visualizzazione del numero telefonico del chiamante.





<sup>2</sup> **VMWI**: Visual Message Waiting Indication = Segnalazione ottica di nuovi messaggi.



## 7 Struttura del menu

### Menu principale

Nel menu principale si giunge premendo il tasto . La procedura da seguire per navigare nel menu ed eseguire immissioni è riportata a pagina 61.









SIST.RISPOSTA	ESEGUI MESSAG.		
	ELIM.TUT.VECCH		
	REGISTRA MEMO		
	IMPOSTAZIONI	SEGRET. ON/OFF	ATTIVO / DISATTIVO
		RITARDO RISP.	2 / 4 / 6 / 8 / SALVA SCATTO
		IMPOSTAZ. OGM	REGISTRAZIONE
			ESEGUI
	ACCESSO REMOTO	ATTIVO / DISATTIVO	
	PIN REMOTO	VECCHIO PIN <sup>1</sup> 	NUOVO PIN  CONFERMA PIN 
	AVVISO MSG	ATTIVO / DISATTIVO	
RUBRICA	RIESAME		
	MEMORIZZAZIONI	INSERIRE NUM 	INSERIRE NOME 
REG.CHIAMATE <sup>2</sup>	RIESAME		
	ELIM.TUTTE CH.		
VOLUME SUON.	DISATTIVO, VOLUME SUON.1 - 6		

<sup>1</sup> Il PIN di sistema impostato in fabbrica corrisponde a "0000".

<sup>2</sup> La visualizzazione o memorizzazione di numeri di chiamata negli elenchi chiamate richiede la visualizzazione del numero di chiamata (**CLIP**<sup>3</sup>). La visualizzazione del numero di chiamata è un servizio aggiuntivo offerto dal proprio gestore di rete telefonica. Si consiglia di rivolgersi al proprio gestore di rete telefonica per ricevere informazioni a riguardo. Per ulteriori informazioni sulla visualizzazione del numero di chiamata vedi  pagina 64.

<sup>3</sup> **CLIP**: Calling Line Identification Presentation = Visualizzazione del numero telefonico del chiamante.

## Struttura del menu

TONO SUONERIA	TONO SUONERIA 1 - 10		
TONI	TONO TASTI	ATTIVO / DISATTIVO	
	BATT. SCARICA	ATTIVO / DISATTIVO	
	FUORI PORTATA	ATTIVO / DISATTIVO	
LINGUA	DEUTSCH / ENGLISH / FRANÇAIS / ITALIANO		
REGISTRA RIC.	PIN SISTEMA: 	TENERE PREMUTO CERCA RICEVIT!	
ANNUL. REG.RIC	PIN SISTEMA: 	RICEVITOREX      ANNULLA REGIST?	
MOD.COMPOSIZ.	TONI		
	IMPULSI		
TEMPO FLASH	BREVE / MEDIO / LUNGO		
IMP. DATA/ORA	IMPOSTA DATA 	IMPOSTA ORA 	
FORMATO ORA	12 ORE		
	24 ORE		
FORMATO DATA	GG/MM/AA/ MM/GG/AA		
ANN.MSG VOCALE	SPEGNIMENTO INDICATORE?		
PIN SISTEMA	VECCHIO PIN <sup>1</sup> 	NUOVO PIN 	CONFERMA PIN 
REIMPOSTAZ.	PIN SISTEMA: 	REIMPOSTA?	

<sup>1</sup> Il PIN di sistema impostato in fabbrica corrisponde a "0000".

## 8 Rubrica telefonica

Nella rubrica telefonica è possibile memorizzare 50 numeri di chiamata con rispettivi nomi.

- Le voci della rubrica telefonica sono elencate in ordine alfabetico. Per accedere direttamente alla voce della rubrica telefonica desiderata, premere la lettera iniziale corrispondente.

### Immettere nomi

I tasti numerici riportano altresì delle lettere. Premendo ripetutamente il relativo tasto si ha modo di selezionare lettere, cifre e caratteri speciali.

<b>1</b>	Immettere spazi vuoti
	Cancellare segni
<b>0</b>	Immettere caratteri speciali



Per immettere la stessa lettera una seconda volta, premere il rispettivo tasto. Attendere fino a quando il cursore si sia spostato di una posizione. Immettere quindi la lettera una seconda volta.

### Creare voci della rubrica telefonica

	Aprire il menu principale
/ <b>RUBRICA</b> ,	Selezionare la rubrica telefonica e confermare
/ <b>MEMORIZZAZIONI</b> ,	Selezionare il sottomenu e confermare
<b>INSERIRE NUM</b> ,  ,	Immettere il numero di chiamata (max. 30 cifre) e confermare
<b>INSERIRE NOME</b> ,  ,	Immettere il nome (max. 15 segni) e salvare

### Modificare le voci della rubrica telefonica

	Aprire il menu principale
/ <b>RUBRICA</b> ,	Selezionare la rubrica telefonica e confermare
/ <b>RIESAME</b> ,	Selezionare il sottomenu e confermare
/  ,	Selezionare la voce della rubrica telefonica e confermare
<b>MODIFICA NUM</b> ,  ,	Modificare il numero di chiamata e confermare
<b>MODIFICA NOME</b> ,  ,	Modificare il nome e memorizzare

### Cancellare le voci della rubrica telefonica

	Aprire il menu principale
/ <b>RUBRICA</b> ,	Selezionare la rubrica telefonica e confermare
/ <b>RIESAME</b> ,	Selezionare il sottomenu e confermare
/  ,	Selezionare la voce della rubrica telefonica e cancellare

# Elenco chiamate

## 9 Elenco chiamate

All'interno dell'elenco chiamate è possibile memorizzare complessivamente 50 numeri telefonici.



La visualizzazione del numero di chiamata (**CLIP<sup>1</sup>**) è un servizio aggiuntivo del proprio gestore di rete telefonica. Nel caso in cui il gestore di rete telefonica supporti il servizio, sul display del telefono è visualizzato il numero di chiamata. Per maggiori dettagli a riguardo, rivolgersi al proprio gestore di rete telefonica.

### Visualizzare numeri di chiamata dall'elenco chiamate

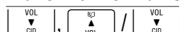

Aprire l'elenco chiamate e selezionare una voce

### Richiamare un interlocutore perso

Il telefono memorizza 50 chiamate nell'elenco chiamate.



Aprire l'elenco chiamate

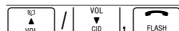

Selezionare la voce e instaurare un collegamento

### Memorizzare nella rubrica telefonica un numero di chiamata presente nell'elenco chiamate

È possibile memorizzare un numero di chiamata direttamente dall'elenco chiamate nella rubrica telefonica.



Aprire l'elenco chiamate



Selezionare la voce



Aprire la funzione



Modificare il numero di chiamata confermare



Modificare il nome e memorizzare

### Cancellare i numeri di chiamata dall'elenco chiamate

Cancellare singoli numeri di chiamata



Aprire l'elenco chiamate

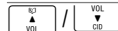

Selezionare la voce



Cancellare la voce

Cancellare tutti i numeri di chiamata



Aprire l'elenco chiamate



Attivare la procedura di cancellazione



Confermare o interrompere la procedura di cancellazione

<sup>1</sup> **CLIP**: Calling Line Identification Presentation = Visualizzazione del numero telefonico del chiamante.

## 10 Ampliamento del sistema telefonico

### Maggior numero di unità portatili



La stazione base prevede la registrazione di complessivamente 5 unità portatili.

### Selezionare unità portatili

Prima di registrare un'unità portatile, passare con la stazione base alla modalità di registrazione. Tenere premuto il tasto di paging sulla base fino ad avvertire un segnale acustico. Fatto questo la base è per un po' in modalità di registrazione. Procedere con l'unità portatile.

5 sec. 

Avviare la modalità di registrazione

Procedere a questo punto con la selezione dell'unità portatile  pagina 66. Utilizzare per la registrazione il codice PIN attualmente impostato  pagina 66.

Una volta eseguita la selezione, all'unità portatile è assegnato un numero di chiamata interno.

### Deselezionare unità portatili



Ogni unità portatile è in grado di deregistrare se stessa o altre unità dalla presente stazione base. Sul display dell'unità portatile deselezionata è visualizzato il messaggio NON REGISTRATO.

Unità portatili sono deselezionate tramite menu. A pagina 66 è indicata la posizione da scorrere nel menu.

# Segreteria telefonica

## 11 Segreteria telefonica

### Esercizio dall'unità portatile

#### Aprire il menu impostazioni

Le impostazioni della segreteria telefonica sono compiute sull'unità portatile ☞ pagina 65.

#### Attivare / Disattivare la segreteria telefonica

Attivazione/Disattivazione della segreteria telefonica sono possibili tramite unità portatile ☞ pagina 65.

#### Durata di registrazione massima

La durata di registrazione massima è di 13 minuti. Non appena la capacità di memoria risulta esaurita non è più possibile registrare dei messaggi nuovi.

#### Ritardo nell'accettazione di chiamata

È possibile scegliere tra un numero da 2 a 8 segnalazioni acustiche di chiamata. In più si ha modo di servirsi della funzione SALVA SCATTO per compiere un'interrogazione a distanza/preliminare senza addebito di scatti. Con questa funzione di interrogazione a distanza/preliminare è possibile verificare gratuitamente la presenza di nuovi messaggi sulla propria segreteria telefonica.

- Se ci sono messaggi nuovi sulla segreteria telefonica, l'apparecchio accetta la telefonata dopo 2 segnalazioni di chiamata.
- Se non ci sono messaggi nuovi sulla segreteria telefonica, l'apparecchio accetta la telefonata solo dopo 4 segnalazioni di chiamata. Riagganciare prima del 4° squillo. In tal modo si evita l'addebito di scatti telefonici.

Ulteriori informazioni sull'interrogazione a distanza ☞ pagina 73.

#### Accettare una chiamata

Anche se la segreteria telefonica ha già risposto ad una chiamata è comunque possibile riprendere la telefonata. La registrazione del messaggio viene in tal caso interrotta.



Rispondere alla chiamata

### Allarme durante i messaggi registrati

Una volta registrato un messaggio o un promemoria, ogni 10 secondi si avverte un segnale acustico ☞ pagina 65.

### Riprodurre messaggi di annuncio

	Aprire il menu principale
SIST.RISPOSTA	Selezionare la segreteria telefonica e confermare
IMPOSTAZIONI	Selezionare il sottomenu e confermare
IMPOSTAZ. OGM	Selezionare il sottomenu e confermare
ESEGUI	Riprodurre il messaggio di annuncio

### Registrare messaggi di annuncio

	Aprire il menu principale
SIST.RISPOSTA	Selezionare la segreteria telefonica e confermare
IMPOSTAZIONI	Selezionare il sottomenu e confermare
IMPOSTAZ. OGM	Selezionare il sottomenu e confermare
REGISTRAZIONE	Registrare il messaggio di annuncio e confermare

L'annuncio che si desidera registrare va parlato in modo chiaro e forte nel microfono della propria unità portatile. A conclusione dell'annuncio, questo è ripetuto ad alta voce.

## Riattivare l'annuncio standard

	Aprire il menu principale
/	Selezionare la segreteria telefonica e confermare
/	Selezionare il sottomenu e confermare
/	Selezionare il sottomenu e confermare
/	Riprodurre il messaggio di annuncio
	Cancellare alcuni messaggi di annuncio durante la riproduzione

## Funzioni a tasti nel menu messaggi

La seguente tabella offre una vista generale delle rispettive funzioni dei singoli tasti nel menu messaggi.

Tasto	Funzioni
	Impostare il volume
	Cancellare il messaggio in corso di riproduzione
	Ripetere il messaggio
2 x	Riprodurre il messaggio precedente
	Messaggio riprodotto è interrotto
	Riprodurre il messaggio successivo
	Concludere la riproduzione

## Tutti i vecchi messaggi sono cancellati

Sono cancellati tutti i messaggi.

	Aprire il menu principale
/	Selezionare la segreteria telefonica e confermare
/	Avviare la procedura di cancellazione
	Confermare la procedura di
/  /	cancellazione oppure interrompere



Una volta cancellati i messaggi non sarà più possibile ripristinarli!

## Registrare un promemoria

Un promemoria è un messaggio che è possibile riprodurre e quindi ascoltare allo stesso modo di un messaggio ricevuto.

	Aprire il menu principale
/	Selezionare la segreteria telefonica e confermare
/	Selezionare il sottomenu e confermare
	Registrare il promemoria e confermare

# Segreteria telefonica

## Esercizio sulla base

### Attivare / Disattivare la segreteria telefonica



Attivare / Disattivare la segreteria telefonica

### Impostare il volume

Il volume è impostabile in 8 livelli.



Avviare la riproduzione

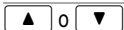

Impostare il volume (L1-L8)

### Riprodurre / Cancellare messaggi registrati

#### Riprodurre un messaggio

I messaggi registrati sono riprodotti nell'ordine in cui sono registrati.



Riprodurre / Interrompere la riproduzione di messaggi



Ripetere il messaggio



Messaggio precedente



Messaggio successivo

#### Cancellare un messaggio



Riprodurre il messaggio da cancellare



Cancellare durante la riproduzione

#### Cancellare tutti i vecchi messaggi



Una volta cancellati i messaggi non sarà più possibile ripristinarli!

Tutti i vecchi messaggi sono cancellati.



Avviare la riproduzione



Cancellare tutti i vecchi messaggi

## Display della segreteria telefonica

Il display della segreteria telefonica indica lo stato dell'apparecchio.

--

Segreteria telefonica disattivata

0-59

Segreteria telefonica attivata, numero di messaggi memorizzati

0-59 lampeggiante

Segreteria telefonica attivata, numero di nuovi messaggi

r-ri

Accesso tramite unità portatile o interrogazione a distanza

FF

Memoria piena



## Interrogazione a distanza

È dato modo di chiamare la propria segreteria telefonica per ascoltare messaggi ricevuti e compiere una serie di funzioni accessorie. Requisito per questa operazione è un telefono abilitato alla selezione a toni.

### Codice PIN per l'interrogazione a distanza

La configurazione iniziale del codice PIN è "0000". Si consiglia di modificare il codice PIN. Modificare il codice PIN ☞ pagina 65.

### Avviare l'interrogazione a distanza



Selezionare il proprio numero di chiamata



Immettere il codice PIN durante la riproduzione del messaggio di annuncio

A questo punto è dato modo di svolgere ulteriori funzioni ☞ Tabella delle funzioni a tasti dell'interrogazione a distanza.

### Attivazione a distanza della segreteria telefonica



Selezionare il proprio numero di chiamata



Avendo dimenticato di inserire la segreteria telefonica, la chiamata è ricevuta solo dopo 10 segnalazioni acustiche di chiamata.



Immettere il codice PIN durante la riproduzione del messaggio di annuncio

**7**

Attivare la segreteria telefonica

A questo punto è dato modo di svolgere altre funzioni.

## Funzioni a tasti dell'interrogazione a distanza



L'interrogazione a distanza è interrotta automaticamente se entro 30 secondi non si procede con una immissione.

La seguente tabella offre una vista generale delle rispettive funzioni dei singoli tasti.

Tasto	Funzioni quando <u>non</u> sono riprodotti messaggi	Funzioni quando sono riprodotti messaggi
<b>2</b>		Cancellare il messaggio durante la riproduzione
2 x <b>2</b>	Cancellare tutti i messaggi vecchi	
<b>4</b>		Ripetere il messaggio in corso
2 x <b>4</b>		Riprodurre il messaggio precedente
<b>5</b>	Riprodurre messaggi	Interrompere la riproduzione
<b>6</b>		Riprodurre il messaggio successivo
<b>7</b>	Attivare la segreteria telefonica	
<b>9</b>	Disattivare la segreteria telefonica	
	Concludere l'interrogazione a distanza	Concludere l'interrogazione a distanza

# In presenza di problemi

## 12 In presenza di problemi

### Linea di assistenza

In presenza di problemi con il telefono, seguire le indicazioni riportate qui di seguito. In caso di problemi tecnici è possibile rivolgersi alla nostra linea di assistenza tecnica chiamando al numero 0900 00 1675 valido per la Svizzera (spese da rete Swisscom alla data di stampa: CHF 2,60/min). In caso di reclami entro il periodo di garanzia, rivolgersi al rivenditore autorizzato. Il periodo di garanzia ricopre 2 anni.

### Domande e risposte

Domande	Risposte
Non è possibile instaurare un collegamento con la stazione base	<ul style="list-style-type: none"><li>- Verificare se la registrazione alla stazione base è stata eseguita con il codice PIN corretto ☞ pagina 66.</li></ul>
Non è possibile condurre una chiamata telefonica	<ul style="list-style-type: none"><li>- Il telefono non è collegato correttamente oppure presenta un guasto. Utilizzare esclusivamente il cavo di collegamento telefonico fornito.</li><li>- Provare con un altro telefono se l'allacciamento telefonico in questione è funzionante.</li><li>- L'alimentatore di rete non è inserito oppure si è in presenza di una caduta di tensione totale.</li><li>- L'accumulatore ricaricabile è scarico o difettoso.</li><li>- La distanza dalla stazione base è troppo grande.</li><li>- Procedura di selezione non impostata correttamente ☞ pagina 66.</li></ul>

Collegamento disturbato, interrotto	<ul style="list-style-type: none"><li>- La distanza dalla stazione base è troppo grande.</li><li>- Luogo di installazione della stazione base errato.</li></ul>
Il sistema non reagisce più	<ul style="list-style-type: none"><li>- Scegliere REIMPOSTAZ.<sup>1</sup> per ripristinare per tutte le funzioni la configurazione iniziale ☞ pagina 66.</li><li>- Estrarre brevemente l'alimentatore di rete dalla presa di corrente.</li></ul>
L'accumulatore ricaricabile si scarica in pochissimo tempo	<ul style="list-style-type: none"><li>- L'accumulatore ricaricabile è scarico o difettoso.</li><li>- Riporre l'unità portatile correttamente nella stazione base. Pulire le superfici di contatto su unità portatile e stazione base con un panno morbido e asciutto.</li><li>- Posizionare l'unità portatile per la durata di 16 ore nella stazione base.</li></ul>
La visualizzazione del numero di chiamata (CLIP <sup>1</sup> ) non funziona	<ul style="list-style-type: none"><li>- La visualizzazione del numero di chiamata è un servizio aggiuntivo offerto dal proprio gestore di rete telefonica. Per maggiori dettagli a riguardo, rivolgersi al proprio gestore di rete telefonica.</li><li>- Il chiamante ha disattivato la trasmissione del proprio numero di chiamata.</li></ul>

<sup>1</sup> CLIP: Calling Line Identification Presentation = Visualizzazione del numero telefonico del chiamante.

La segreteria telefonica non registra alcun messaggio

- Assicurarsi che la segreteria telefonica sia inserita.
- Verificare che la memoria della segreteria telefonica non sia piena. Cancellare se necessario i messaggi dalla memoria ☞ pagina 71.

Non è possibile compiere un'interrogazione a distanza

- Verificare se il codice di sicurezza per l'interrogazione a distanza utilizzato è corretto ☞ pagina 65.
- Il telefono utilizzato per compiere l'interrogazione a distanza deve passare alla procedura di selezione a toni.

# Specifiche tecniche

## 13 Specifiche tecniche

### Specifiche tecniche

Caratteristica	Valore
Standard	<b>DECT<sup>1</sup></b>
Alimentazione elettrica (stazione base)	Ingresso: 100-240 V, 50/60 Hz Uscita: 6 V 600 mA
Alimentazione elettrica (stazione di carica)	Ingresso: 100-240 V, 50/60 Hz Uscita: 6 V 300 mA
Portata	Esterno: ca. 300 m Interno: ca. 50 m
Durata di stand-by	fino a 100 ore
Max. durata di conversazione	fino a 8 ore
Accumulatore ricaricabile	NiMH 2,4 V 500 mAh
MOD.COMPOSIZ.	TONI IMPULSI
TEMPO FLASH	100 ms, 300 ms, 600 ms

<sup>1</sup> **DECT**: Digital Enhanced Cordless Telecommunication = Standard per telefoni senza cavo.

### Configurazione iniziale

#### Unità portatile

La configurazione iniziale è ripristinata nel menu.  
A pagina 66 è indicata la posizione da scorrere nel menu.

VOLUME SUON.	VOLUME SUON. 3
TONO SUONERIA	TONO SUONERIA 2
TONO TASTI	ATTIVO
BATT. SCARICA	ATTIVO
FUORI PORTATA	ATTIVO
LINGUA	DEUTSCH
FORMATO ORA	24 ORE
FORMATO DATA	GG/MM/AA

#### Stazione base

La configurazione iniziale è ripristinata nel menu.  
A pagina 66 è indicata la posizione da scorrere nel menu.

VOLUME SUON.	3
MOD.COMPOSIZ.	TONI
TEMPO FLASH	BREVE
PIN SISTEMA	0000

### Segreteria telefonica

SEGRET. ON/OFF	ATTIVO
RITARDO RISP.	6
AVVISO MSG	ATTIVO
PIN REMOTO	0000

### Dichiarazione di conformità

Questo apparecchio risponde a quanto disposto dalla Direttiva UE 1999/5/CE concernente le apparecchiature radio, le apparecchiature terminali di telecomunicazioni e il reciproco riconoscimento della loro conformità. La conformità con la Direttiva di cui sopra viene confermata dal marchio CE applicato sull'apparecchio. Per la dichiarazione di conformità completa si prega di voler usufruire del servizio gratuito di download dal nostro sito Internet [www.switel.com](http://www.switel.com).



# Consigli per la cura / Garanzia

## 14 Consigli per la cura / Garanzia

### Consigli per la cura

- Pulire le superfici degli apparecchi con un panno morbido e antipelucchi.
- Non utilizzare mai detergenti o solventi.

### Garanzia

Gli apparecchi SWITEL sono costruiti e collaudati in osservanza dei processi di produzione più moderni. L'impiego di materiali selezionati e tecnologie altamente sviluppate sono garanti di una perfetta funzionalità e lunga durata in vita. La garanzia non viene considerata esecutiva qualora la causa del malfunzionamento dell'apparecchio sia riconducibile al gestore della rete telefonica oppure se questa è da attribuirsi ad un impianto telefonico interno interposto. La garanzia non si estende a batterie, accumulatori o pacchi batteria utilizzati all'interno degli apparecchi. Il periodo di garanzia ricopre 24 mesi a partire dalla data di acquisto.

Entro il periodo di garanzia si procederà all'eliminazione gratuita di tutti i guasti dovuti a difetti di materiale o produzione. Il diritto di garanzia cessa in caso di interventi da parte dell'acquirente o di terzi. Danni derivanti da un impiego o esercizio non conforme agli usi previsti, a naturale usura, a errato montaggio o errata conservazione, a collegamento o installazione impropri, dovuti a forza maggiore o ad altri influssi esterni non sono coperti da garanzia. In qualità di produttore ci riserviamo il diritto, in caso di reclami, di riparare o sostituire le parti difettose o di rimpiazzare l'apparecchio. Parti o apparecchi sostituiti passano di nostra proprietà. Sono esclusi diritti di risarcimento per danni qualora non siano dovuti a intenzione o colpa grave del costruttore.

Nel caso in cui il presente apparecchio dovesse ciò nonostante presentare un difetto durante il periodo di garanzia, si prega di rivolgersi esclusivamente al negozio di rivendita dell'apparecchio SWITEL assieme al relativo scontrino di acquisto. In base alle presenti disposizioni, tutti i diritti di garanzia dovranno essere fatti valere esclusivamente nei confronti del rivenditore autorizzato. Decorso il termine di due anni dalla data di acquisto e consegna dei nostri prodotti non sarà più possibile fare valere alcun diritto di garanzia.

15 Indice alfabetico

**A**

Accettare una chiamata, 70  
 Accettazione di chiamata, 62  
 Agganciare il ricevitore, 62  
 Allarme, 70  
 Ampliamento, 69  
 Attivare, 63, 72  
 Attivazione a distanza, 73

**C**

Cancellare, 71, 72  
 Cancellare i messaggi, 72  
 Caricare, 58  
 Chiamata in attesa, 63  
 Chiamate a conferenza, 63  
 Chiamate interne, 62  
 CLIP, 64  
 Codice PIN, 73  
 Compiere telefonate, 62  
 Concludere la chiamata, 62  
 Configurazione iniziale, 76  
 Consigli per la cura, 78  
 Contenuto della confezione, 57

**D**

Data, 58  
 Deselezione, 69  
 Dichiarazione di conformità, 77  
 Disattivare, 63, 72  
 Display, 60, 72  
 Domande e risposte, 74  
 Durata di conversazione, 63  
 Durata di registrazione massima , 70

**E**

Elementi di comando, 59  
 Elenco chiamate, 68  
 Eliminazione di guasti, 74  
 Esercizio, 60  
 Esercizio dall'unità portatile, 70  
 Esercizio sulla base, 72

**F**

Funzione di richiamata, 62, 68  
 Funzione R, 64  
 Funzione vivavoce, 63  
 Funzioni a tasti, 71, 73

**G**

Garanzia, 78

**I**

Immettere nomi, 67  
 Immettere testi, 67  
 Impianti telefonici interni, 64  
 Indicazioni di sicurezza, 56  
 Inserire l'accumulatore ricaricabile, 58  
 Interrogazione a distanza, 73

**L**

Linea di assistenza, 74

**M**

Memorizzare, 68  
 Menu impostazioni, 70  
 Menu principale, 65  
 Messa in funzione, 57  
 Messaggi, 72  
 Messaggi di annuncio, 70  
 Modalità di risparmio energetico, 61  
 Modalità di stand-by, 61  
 Modalità ECO, 58  
 Modi di scrittura, 60

**O**

Ora, 58

**P**

Paging, 63  
 Pausa di selezione, 64  
 Problemi, 74

**R**

Registrare, 70  
 Registrare un promemoria, 71  
 Ricerca dell'unità portatile, 63  
 Riduzione delle radiazioni, 68  
 Ripetizione di chiamata, 62  
 Riprodurre, 70, 72  
 Riscontro, 63  
 Risparmio di addebiti, 70  
 Ritardo, 70  
 Rubrica telefonica, 62, 67

**S**

Salvare, 61, 67  
 Segreteria telefonica, 70  
 Segreteria telefonica  
 integrata nella rete telefonica, 64  
 Selezionare, 62  
 Selezione, 69  
 Servizi aggiuntivi, 64  
 Silenziamento, 63  
 Silenziamento del microfono, 63  
 Simboli, 60  
 Simboli di display, 60  
 Specifiche tecniche, 76  
 Stato di carica  
 dell'accumulatore ricaricabile, 58  
 Stazione base, 59  
 Struttura del menu, 65

**T**

Trasferimento di chiamata, 62

**U**

Unità base, 57  
 Unità portatile, 69

**V**

Visualizzazione del  
 numero di chiamata, 64, 68  
 VMWI, 64  
 Voci della rubrica telefonica, 61, 67  
 Volume, 72  
 Volume del ricevitore, 63





1	Safety Information . . . . .	82
2	Preparing the Telephone . . . . .	83
3	Operating Elements . . . . .	85
4	Preliminary Information . . . . .	86
5	Telephoning . . . . .	88
6	PBX / Supplementary Services . . . . .	90
7	Menu Structure . . . . .	91
8	Phone Book . . . . .	93
9	Call Log (CID - Caller Identification) . .	94
10	Extending the Telephone System . . . .	95
11	Answering Machine . . . . .	96
12	In Case of Problems . . . . .	100
13	Technical Properties . . . . .	102
14	Maintenance / Guarantee . . . . .	104
15	Index . . . . .	105

# Safety Information

## 1 Safety Information

Please read this operating instruction manual thoroughly.

### Intended use

The telephone is suitable for telephoning within a public telephone network system. Any other use is considered unintended use. Unauthorised modification or reconstruction is not permitted. Under no circumstances open the device or complete any repair work yourself.

### Installation location

Prevent excessive exposure to smoke, dust, vibration, chemicals, moisture, heat and direct sunlight.

Do not use the handset in potentially explosive areas.

### Power adapter plug



**Attention:** Only use the power adapter plug supplied because other power supplies could damage the telephone. Ensure access to the power adapter plug is not obstructed by furniture or such.

### Rechargeable battery pack



**Attention:** Never throw batteries into a fire. Only use batteries of the same type. Pay attention to correct polarity. Incorrect polarity of the batteries represents a risk of explosion during charging.

### Power failure

The telephone cannot be used to make calls in the event of a power failure. Always keep a wired telephone which operates without an external power supply available in case of emergency situations.

## Medical equipment



**Attention:** Never use the telephone in the vicinity of medical equipment. Effects on such equipment cannot be fully ruled out.

DECT<sup>1</sup> telephones can cause an unpleasant humming sound in hearing aids.

## Hearing aid compatible

The telephone is compatible with most popular hearing aids on the market. However, it cannot be guaranteed that all hearing aids will work perfectly.

## Disposal

In order to dispose of your device, take it to a collection point provided by your local public waste authorities (e.g. recycling centre). According to laws on the disposal of electronic and electrical devices, owners are obliged to dispose of old **electronic and electrical devices** in a separate waste container. The adjacent symbol indicates that the device must not be disposed of in normal domestic waste!



### Risks to health and the environment from batteries!



Never open, damage or swallow batteries or allow them to pollute the environment. They could contain toxic and ecologically harmful heavy metals. You are legally obliged to dispose of power packs and batteries at the point of sale or in the corresponding containers provided at collection points by local public waste authorities. Disposal is free of charge. The above symbols indicate that the batteries must not be disposed of in domestic waste and that they must be disposed of at an authorised collection point.

**Packaging materials** must be disposed of according to local regulations.

<sup>1</sup> DECT: Digital Enhanced Cordless Telecommunication = Standard for cordless telephones.

## 2 Preparing the Telephone

### Safety information



**Attention:** It is essential to read the Safety Information in Chapter 1 before starting up.

### Checking the package contents

The package contains:

Content	DFT 137X model			
	DFT 1371	DFT 1372 <sup>1</sup>	DFT 1373 <sup>1</sup>	DFT 1374 <sup>1</sup>
Base station with power adapter plug	1	1	1	1
Charging station with power adapter plug	-	1	2	3
Handset	1	2	3	4
Telephone connection line	1	1	1	1
Battery pack	1	2	3	4
Operating instructions	1	1	1	1

<sup>1</sup> Visit [www.switel.com](http://www.switel.com) to find out whether the telephone set is already available.

### Connecting the base station



**Attention:** Position the base station at least 1 m away from other electronic devices, otherwise there is a risk of mutual disturbance.

Connect the base station as illustrated in the diagram. For reasons of safety, only use the power adapter plug and telephone connection line supplied.

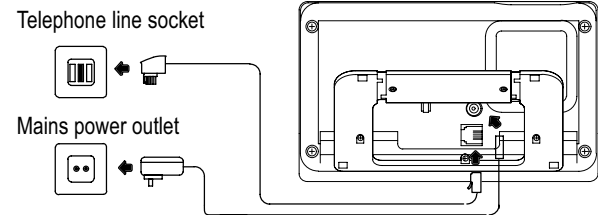

### Important note

Your phone's base station is supplied with an energy-efficient switching power supply SSA-5AP-09EU060060 (Input 100~240 V<sub>AC</sub>, Output 6 V<sub>DC</sub>, 600 mA). The adaptor input power without load is approx. 0.15 W. The average efficiency is approx. 65 %.

The electrical consumption of the base is:

- in operation mode (idle/call): approx. 1.5 W
- during charging of the handset: approx. 2.5 W

The charger(s) delivered with a telephone set is/are supplied with an energy-efficient switching power supply S002CV0600030 (Input 100~240 V<sub>AC</sub>, Output 6 V<sub>DC</sub>, 300 mA). The adaptor input power without load is approx. 0.15 W. The average efficiency is approx. 60 %.

The electrical consumption of the charger is:

- without handset charging: approx. 0.15 W
- during charging of the handset: approx. 1.2 W

# Preparing the Telephone

## Inserting the battery pack

Slide the battery compartment cover downwards and then remove it. Connect the plug on the battery pack in the socket in the battery compartment. Insert the battery pack in the battery compartment. Only use the battery pack supplied. Pay attention that the cable is not jammed. Replace the cover back on the battery compartment and slide it upwards until it snaps into place.

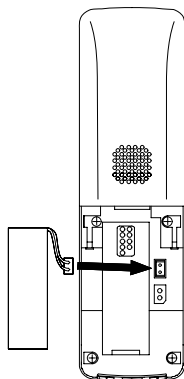

## Charging the battery pack

 Before the handset is used for the first time, insert it in the base station/charging station for **at least 16 hours**.

When the handset is properly inserted in the base station / charging station, the charge control lamp lights up. The handset warms up during the charging process. This is normal and does not represent a risk. Do not charge the handset with charging units from other manufacturers. The current **battery charge status** is indicated in the display:



Full



2/3 Full



Low



Empty

## Setting the time and date on the handset

The time and date are set via the menu. Refer to Page 92 for the sequence of menu option selections.

## Private branch exchanges

The information on Page 90 explains how to install your telephone in a private branch exchange.

## Low-radiation operation (ECO mode)

In talk mode, radiation is reduced depending on the distance between the handset and base station.



## 3 Operating Elements

The buttons in this operating manual are subsequently depicted with a uniform contour. Therefore, slight deviations in the appearance of the symbols on the telephone buttons compared to those depicted here are possible.

### Handset

- 1 Earpiece
- 2 Display
- 3 MENU/SELECT button
- 4 Navigate upwards / Increase volume / Phone book
- 5 On-hook button / Back / Delete / Switch off
- 6 Navigate downwards / Reduce volume / CID (call log)
- 7 # button
- 8 Internal call
- 9 Muting button / Delete
- 10 Microphone
- 11 Redialling / Insert dialling pause
- 12 X button
- 13 Digit keys
- 14 Call button / R button
- 15 Handsfree

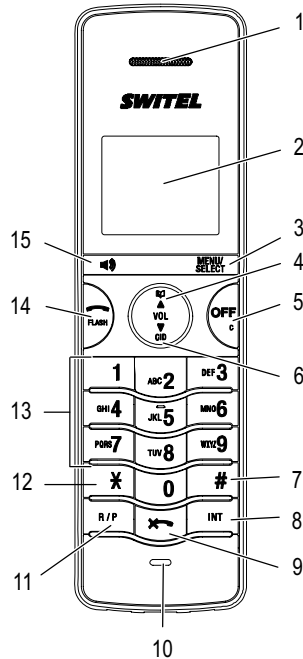

### Base station (answering machine)

- 1 LED: call indicator
- 2 Locate handset (paging)
- 3 Answering machine on / off
- 4 Delete
- 5 Display
- 6 LED: Charge indicator
- 7 Volume +
- 8 Volume -
- 9 Next message
- 10 Play / Stop
- 11 Repeat message / Previous message
- 12 Loudspeaker
- 13 Charging contacts

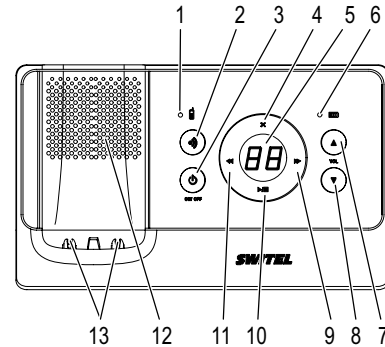













# Preliminary Information

















## 4 Preliminary Information

This chapter provides basic information on using the operating instruction manual and the telephone.

### Description of operating sequences in the manual

Display	Description
	Displays the contour of buttons
	Press the button depicted briefly
3 sec. 	Press the button depicted for 3 seconds
Hold 	Press and hold the button depicted
Release 	Release the button depicted
	Enter digits or letters
	Handset rings
	Base station rings
	Remove the handset from the base station
	Place the handset in the base station
	Depicts text in the display
	Depicts icons in the display

### Icons and texts in the handset display

Icon	Description
	Displays current battery charge capacity.
DD/MM	Displays the date;  Page 92.
hh:mm	Displays the time;  Page 92.
	New entry in the call log;  Page 94.
	The handsfree facility is activated;  Page 89.
	Answering machine provided in the telephone network. <b>VMWI</b> <sup>1</sup> - Supplementary service offered by telephone network providers;  Page 90.
	The microphone is deactivated (muted);  Page 89.
	The ringing tone has been switched off;  Page 91.
	The answering machine is switched on;  Page 96.
	New messages are recorded on the answering machine.

<sup>1</sup> **VMWI: Visual Message Waiting Indication** = Visual indicator that new messages have been recorded.

## Standby mode













All descriptions in this operating manual assume that the handset is in Standby mode. Press the  button, several times if necessary, to activate Standby mode.

## Energy-save mode

When the handset has been in Standby mode for some time, it automatically switches to energy-save mode. The buttons and display no longer light up.

## Navigating in the menu

All the functions can be accessed via the various menus. Refer to the Menu Structure  Page 91 for information on how to access each respective function.















	Open the main menu
 or 	Select the required submenu
	Open the submenu
 or 	Select the required function
	Open the function
 or 	Select the required setting
	Use the digit keys to enter numbers or letters
	Confirm the input
	Move one level back
	Interrupt the programming and saving processes and return to Standby mode



Every process is automatically cancelled if there is no input within 30 seconds.

## Creating phone book entries - example

The way in which to navigate through the menus and select settings is explained by means of the example **Creating phone book entries**. Proceed as in this example for all the settings.

	Open the main menu
 /  	Select Phonebook and confirm it
	
 /  	Select the submenu and confirm it
	
 ,  , 	Enter the phone number (max. 30 digits) and confirm it
 ,  , 	Enter the name (max. 15 characters) and confirm it

# Telephoning

## 5 Telephoning

### Taking a call

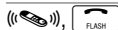

Take the call

### Ending a call



End the call

### Making a call



Enter the phone number (max. 30 digits)



Delete the last digit if incorrect



Dial the phone number



It is also possible to press the Call button first to obtain the dialling tone for an outside line. The digits then entered are dialled immediately. It is not possible to correct wrong digits individually using this dialling procedure.

### Redialling

The telephone stores the last 5 numbers dialled in a redialling list.



Open the redialling list



Select the entry required and dial it

### Calling back calls received

The telephone stores the numbers of the last 50 calls received in a call log.



Open the call log

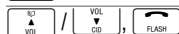

Select the entry required and dial it

### Dialling numbers from the phone book

Phone numbers must have been stored in the phone book for this function; Pages 87 and 93.



Open the phone book

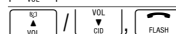

Select the entry required and dial it

### Internal calls<sup>1</sup>

#### Making internal calls

There must be two or more handsets (HS1, HS2, ...) registered on your base station in order to make internal calls free of charge.

HS1: , e.g.

Dial the internal call number of the handset required

HS2:

Take the internal call on the other handset

HS1/HS2:

End the internal call

#### Forwarding external calls internally

HS1: , e.g.

Dial the internal handset number while making the external call

HS2:

Take the internal call on the other handset

HS1:

Forward the call



If the handset called does not answer, take the external call back by pressing the button.

<sup>1</sup> Internal calls are only possible when at least two handsets are registered in the system; "Checking the contents of the package" on Page 83.



## Holding a call / brokering

While a call is in progress, it is possible to dial another handset in order to consult with someone. The external caller is put on hold while you converse with the second, internal person called. You can repeat this procedure as often as required.

HS1: , e.g.  Dial the internal handset number while making the external call

HS2:  Take the internal call on the other handset

HS1:  Switch between callers

## Making conference calls

An external call can be transferred to include another internal handset for a conference call.

HS1: , e.g.  Dial the internal handset number while making the external call

HS2:  Take the internal call on the other handset

HS1: Hold down  Start the conference

HS1/HS2:  End the conference

## Setting the receiver volume

The volume can be adjusted to one of 5 levels during a call.

 or  Select the required volume

## Handsfree

This function is used to listen to the caller via the loudspeaker.

 Enable handsfree talking

 Disable handsfree talking

## Displaying the duration of a call

The duration of a call is displayed in hours, minutes and seconds during the call.

## Muting the microphone in the handset

The microphone in the handset can be activated and deactivated during a telephone conversation.

 Deactivate the microphone (muting on)

 Activate the microphone

## Searching for the handset (Paging)

If you have mislaid your handset, you can sound a paging tone to find it.

  Activate the paging tone

 or  Deactivate the paging tone

## Switching the handset off and on

You can switch the handset off to save the battery pack.

1 sec. ,  Switch off the handset

5 sec.  Switch on the handset

# PBX / Supplementary Services

## 6 PBX / Supplementary Services

### R function in private branch exchanges

If the telephone is connected to a private branch exchange, functions such as transferring calls and automatic call back can be used via the  button. Refer to the operating manual provided with your private branch exchange as to which Flash time must be set in order to use these functions. The sales outlet where you purchased the exchange can provide information as to whether the telephone will work properly with the exchange. The Flash time is set using the menu. Refer to Page 92 for the sequence of menu option selections.

### R function and supplementary services

Your telephone supports supplementary services provided by your telephone network provider, such as brokering, call waiting and conference facilities. These supplementary services can be used by implementing the  button. Please contact your telephone network provider regarding which Flash time must be set to use the supplementary services. Also contact your telephone network provider with regard to enabling supplementary services. The Flash time is set using the menu. Refer to Page 92 for the sequence of menu option selections.

### Caller number display (CLIP<sup>1</sup>)



The caller number display (CLIP) is a supplementary service offered by your telephone network provider. Contact your network provider for further information.

If this function is available with your telephone line, the number of the caller appears in the display when the phone rings. If the caller has suppressed transmission of his phone number, the corresponding message appears in the display. The phone number is not displayed and, as a result, is not stored in the call log (CID list).

### Dialling pause

When using private branch exchanges, it is necessary to dial an access code to obtain the dialling tone for an outside line. When using some older private branch exchanges, it takes a little time before the dialling tone becomes audible. In the case of such private branch exchanges, a dialling pause can be inserted after the number for an outside line in order to continue dialling directly without having to wait for the dialling tone.

2 sec. 

Insert a dialling pause

The actual phone number is dialled a certain time after the number for an outside line.



The dialling pause can also be entered with the phone numbers in the phone book.

### Answering machine in the telephone network

An answering machine in the telephone network is a supplementary service offered by many telephone network providers. If your telephone network provider offers an answering machine in the telephone network for you, an icon on the display informs you of new messages received (**VMWI**<sup>2</sup>). This function can only be used when your telephone network provider actually offers the service. Contact your network provider for further information.





<sup>1</sup> **CLIP**: Calling Line Identification Presentation = Displays the caller's phone number.

<sup>2</sup> **VMWI**: Visual Message Waiting Indication = Visual indicator that new messages have been recorded.

## 7 Menu Structure

### Main menu

Press the  button to open the main menu. Navigation through the menus and how to enter data is explained on Page 87.









ANS. SYSTEM	PLAY MESSAGE		
	DEL ALL OLD		
	RECORD MEMO		
	SETTINGS	ANSWER ON/OFF	ON/OFF
		ANSWER DELAY	2 / 4 / 6 / 8 / TOLL SAVER
		OGM SETTINGS	RECORD
			PLAY
	REMOTE ACCESS	ON/OFF	
	REMOTE PIN	OLD PIN <sup>1</sup> 	NEW PIN  CONFIRM PIN 
	MSG ALERT TONE	ON/OFF	
PHONEBOOK	REVIEW		
	STORE	ENTER NUMBER 	ENTER NAME 
CALL LOG <sup>2</sup>	REVIEW		
	DEL ALL CALLS		
RINGER VOLUME	OFF, RINGER VOLUME 1 - 6		

<sup>1</sup> The default PIN code is "0000".

<sup>2</sup> The call number display (**CLIP**<sup>3</sup>) is required to be able to display and store phone numbers in the call logs. The caller number display (CLIP) is a supplementary service offered by your telephone network provider. Contact your network provider for further information. For further information on the CLIP feature, refer to  Page 90.

<sup>3</sup> **CLIP: Calling Line Identification Presentation** = Displays the caller's phone number.

## Menu Structure

RINGER TONE	RINGER TONE 1 - 10		
TONES	KEY TONE	ON/OFF	
	BATTERY LOW	ON/OFF	
	OUT OF RANGE	ON/OFF	
LANGUAGE	DEUTSCH / ENGLISH / FRANÇAIS / ITALIANO		
REGISTER HS	SYSTEM PIN: 	PRESS AND HOLD PAGE BUTTON!	
DE-REGISTER HS	SYSTEM PIN: 	HANDSETX	DE-REGISTER?
DIAL MODE	TONE		
	PULSE		
FLASH TIME	SHORT/MEDIUM/LONG		
SET DATE/TIME	SET DATE 	SET TIME 	
TIME FORMAT	12-HR		
	24-HR		
DATE FORMAT	DD/MM/YY/ MM/DD/YY		
CLR VOICEMAIL	TURN OFF INDICATOR?		
SYSTEM PIN	OLD PIN <sup>1</sup> 	NEW PIN 	CONFIRM PIN 
RESET	SYSTEM PIN: 	RESET?	

<sup>1</sup> The default PIN code is "0000".

## 8 Phone Book

You can use the phone book to store up to 50 phone numbers together with the associated names.

- The phone book entries are arranged alphabetically. To access the required phone book entry directly, press the first letters of the corresponding name.

### Entering names

Letters are also imprinted on the digit keys. Letters, digits and special characters are entered by pressing the relevant key the respective number of times.

	Enter a space
	Delete character
	Enter a special character



To enter the same letter twice, press the button to enter the letter. Wait until the cursor skips one position forwards. Enter the letter again.

### Creating phone book entries

	Open the main menu
/	, Select Phonebook and confirm it
/	, Select the submenu and confirm it
	Enter the phone number (max. 30 digits) and confirm it
	Enter the name (max. 15 characters) and confirm it

### Modifying phone book entries

	Open the main menu
/	, Select Phonebook and confirm it
/	, Select the submenu and confirm it
/	, Select a phone book entry and confirm it
	Change the number and confirm it
	Change the name and save it

### Deleting phone book entries

	Open the main menu
/	, Select Phonebook and confirm it
/	, Select the submenu and confirm it
/	, Select a phone book entry and delete it

# Call Log

## 9 Call Log (CID - Caller Identification)

A total of 50 phone numbers are stored in the call log.



The caller number display (**CLIP**<sup>1</sup>) is a supplementary service offered by your telephone network provider. The caller's number appears in the display if the service is offered by your telephone network provider. Contact your network provider for further information.

### Displaying numbers in the call log

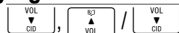

Open the call log and select an entry

### Calling back calls received

The telephone stores the numbers of the last 50 calls received in a call log.



Open the call log

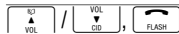

Select the entry required and dial it

### Storing a phone number in the call log in the phone book

A phone number in the call log can be stored in the phone book directly.



Open the call log

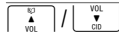

Select an entry



Open the function



Change the number and confirm it



Change the name and save it

### Deleting phone numbers from the call log

#### Deleting individual phone numbers



Open the call log



Select an entry



Delete the entry

#### Deleting all phone numbers



Open the call log

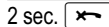

Activate the deleting process



Confirm or cancel the deleting process



<sup>1</sup> **CLIP**: Calling Line Identification Presentation = Displays the caller's phone number.

## 10 Extending the Telephone System



### Multiple handsets

Up to 5 handsets can be registered on the base station.

#### Registering handsets

Before starting to register a handset, switch the base station to Registration mode. Press and hold the Paging button on the base station until you hear an acoustic signal. The base station is then in Registration mode for a short time. Continue with the handset.

5 sec.  Activate Registration mode

Now register the handset;  Page 92. The currently valid PIN code is used for registration purposes;  Page 92.

The handset is automatically assigned an internal call number following registration.

#### Deregistering handsets



Each handset can deregister itself and other handsets registered on the base station. After deregistration, the message NOT REGISTERED appears in the display of the deregistered handset.

Handsets are deregistered via the menu. Refer to Page 92 for the sequence of menu option selections.

# Answering Machine

## 11 Answering Machine

### Operating via the handset

#### Opening the Ans System menu

The answering machine settings are defined by using the handset,  Page 91.

#### Switching the answering machine on/off

The answering machine can be switched on and off via the handset  Page 91.

#### Maximum recording time

The maximum recording time is 13 minutes. When the memory capacity for new messages is exhausted, no further messages are recorded.

#### Ringng delay for taking a call

You can select from 2 to 8 rings. In addition, the TOLL SAVER setting is also available for pre-remote access free of charge. The toll-saving pre-remote access feature can be used to check whether new messages have been received on your answering machine from a distant telephone.

- If new message have been recorded on your answering machine, your call is taken after 2 rings.
- If no new message have been recorded on your answering machine, your call is taken after 4 rings. End the call before the 4th ring. This means that no charges ensue.

For further information on remote access;  Page 99.

#### Taking a call being recorded

It is possible to take a call even if the answering machine has already begun to take it. Recording of the message is stopped in this case.















Take the call













### Message waiting alarm

If a new message or a memo is waiting, the set will sound a beep signal every 10 seconds;  Page 91.

### Playing the outgoing message

		Open the main menu
 / 	<b>ANS. SYSTEM</b>	Select the answering system and confirm it
		Select the submenu and confirm it
 / 	<b>SETTINGS</b>	Select the submenu and confirm it
		Select the submenu and confirm it
 / 	<b>OGM SETTINGS</b>	Select the submenu and confirm it
		Select the submenu and confirm it
 / 	<b>PLAY</b>	Play the outgoing message

### Recording outgoing messages

		Open the main menu
 / 	<b>ANS. SYSTEM</b>	Select the answering system and confirm it
		Select the submenu and confirm it
 / 	<b>SETTINGS</b>	Select the submenu and confirm it
		Select the submenu and confirm it
 / 	<b>OGM SETTINGS</b>	Select the submenu and confirm it
		Select the submenu and confirm it
 / 	<b>RECORD</b>	Record the outgoing message and confirm it



JKL 5

Speak your message clearly and precisely in the microphone on the handset. On ending the message, it is played back.



## Reactivating the pre-recorded message

	Open the main menu
/	Select the answering system and confirm it
/	Select the submenu and confirm it
/	Select the submenu and confirm it
/	Play the outgoing message
	Delete the outgoing message while it is playing

## Key function assignment, Play Message menu

The following table provides an overview of the respective functions assigned to the individual buttons in the Play Message menu.

Button	Function
	Set the volume
	Delete message during playback
	Repeat playback of the message
	Play the previous message
	Stop playback
	Play the next message
	End playback

## Delete all old messages

All the messages are deleted.

	Open the main menu
/	Select the answering system and confirm it
/	Select the submenu and confirm it
	Activate the deleting process
	Confirm the deleting process or cancel it
/	
	Messages which have been deleted cannot be restored!

## Recording a memo

A memo is a message left for other machine users and can be played in the same way as an incoming message.

	Open the main menu
/	Select the answering system and confirm it
/	Select the submenu and confirm it
	Record the memo and confirm it

# Answering Machine

## Operating via the base station

### Switching the answering machine on/off



Switch the answering machine on/off

### Setting the volume

The volume can be set to one of 8 different levels.



Start playback

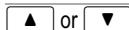

Set the volume (L1-L8)

### Playing/Deleting recorded messages

#### Playing the messages

The recorded messages are played back in the sequence they were recorded.



Play/Stop the messages



Repeat playback of the message



Play the previous message



Play the next message

#### Deleting a message



Play the message to be deleted



Delete message while it is being played

#### Deleting all old messages



Messages which have been deleted cannot be restored!

All the old messages are deleted.



Start playback



Delete all the old messages

## Answering machine display

The answering machine's display indicates the unit's status.

--

The answering machine is switched off

0-59

The answering machine is switched on  
Number of recorded messages

0-59 flashing

The answering machine is switched on  
Number of new messages

r-Fi

Access via a handset or remote access

FF

Memory full

## Remote access

You can call your answering machine from another telephone to play messages or execute other functions. A condition is that you use a telephone which implements tone dialling.

### PIN code for remote access

The default setting of the PIN code is "0000". It is recommended to change the default PIN code. Changing the PIN code; Page 91.

### Starting remote access



Dial your own phone number



Enter the PIN code while the OGM is playing

You can now execute other functions; Table: Key function assignment for remote access.

### Remote activation of the answering machine



Dial your own phone number



If you forgot to switch your answering machine on, your call is taken after 10 rings.



Enter the PIN code while the OGM is playing

**7**

Activate the answering machine

You can now execute other functions.

## Key function assignment for remote access



Remote access is automatically cancelled if there is no input within 30 seconds.

The following table provides an overview of the respective functions assigned to the individual buttons.

Button	Functions when <u>no</u> messages are played	Functions when messages are played
<b>2</b>		Delete message during playback
2 x <b>2</b>	Delete all old messages	
<b>4</b>		Repeat playback of current message
2 x <b>4</b>		Play the previous message
<b>5</b>	Play the message	Stop playback
<b>6</b>		Play the next message
<b>7</b>	Activate the answering machine	
<b>9</b>	Switch off the answering machine	
	End remote access	End remote access



# In Case of Problems

## 12 In Case of Problems

### Service Hotline

Should problems arise with the telephone, please refer to the following information first. In the case of technical problems, you can contact our hotline service, Tel. 0900 00 1675 within Switzerland (Swiss-com fees at time of going to print: CHF 2.60/min). In the case of claims under the terms of guarantee, please contact your sales outlet. There is a 2 year period of guarantee.

### Problems and solutions

Problems	Solutions
No connection to base station possible	<ul style="list-style-type: none"> <li>- Check that the handset has been registered on the base station with the correct PIN code;  Page 92.</li> </ul>
No telephone calls possible	<ul style="list-style-type: none"> <li>- The telephone is not connected properly or is defective. Only use the telephone connection cable supplied.</li> <li>- Test whether the telephone connection is in order by using another telephone.</li> <li>- The power adaptor plug is not plugged in or there is a complete power failure.</li> <li>- The rechargeable battery pack is empty or defect.</li> <li>- The handset is too far from the base station.</li> <li>- The wrong dialling mode is set;  Page 92.</li> </ul>

Connection is disturbed or cut off	<ul style="list-style-type: none"> <li>- The handset is too far from the base station.</li> <li>- The base station is in an unsuitable location.</li> </ul>
The system no longer responds	<ul style="list-style-type: none"> <li>- Return all the functions to their default status using the "RESET" function;  Page 92.</li> <li>- Disconnect the power adapter plug briefly from the power socket.</li> </ul>
The battery pack is empty in a short time	<ul style="list-style-type: none"> <li>- The battery pack is empty or defect.</li> <li>- Place the handset in the base station properly. Clean the contact surfaces on the handset and base station with a soft, dry cloth.</li> <li>- Place the handset in the base station for 16 hours.</li> </ul>
The caller number display (CLIP <sup>1</sup> ) does not function	<ul style="list-style-type: none"> <li>- The caller number display (CLIP) is a supplementary service offered by your telephone network provider. Contact your network provider for further information.</li> <li>- The caller has suppressed the transmission of their phone number.</li> </ul>

<sup>1</sup> **CLIP:** Calling Line Identification Presentation = Displays the caller's phone number.

The answering machine does not record any messages

- Ensure that the answering machine is switched on.
- Check whether the answering machine memory is full. Delete messages from the memory, if necessary;  Page 97.

---

Remote access is not possible

- Check that the correct security code has been entered for remote access;  Page 91.
- The telephone used for remote access must be set to tone dialling.

# Technical Properties

## 13 Technical Properties

### Technical data

Feature	Value
Standard	<b>DECT<sup>1</sup></b>
Power supply (base station)	Input: 100-240 V, 50/60 Hz Output: 6 V, 600 mA
Power supply (charging station)	Input: 100-240 V, 50/60 Hz Output: 6 V, 300 mA
Range	Outdoors: Approx. 300 m Indoors: Approx. 50 m
Standby time	Up to 100 h
Max. talk time	Up to 8 h
Rechargeable battery pack	NiMH 2.4 V, 500 mAh
DIAL MODE	TONE PULSE
FLASH TIME	100 ms, 300 ms, 600 ms

### Default settings

#### Handset

The default settings can be restored via the menu.  
Refer to Page 92 for the sequence of menu option selections.

RINGER VOLUME	RINGER VOLUME 3
RINGER TONE	RINGER TONE 2
KEY TONE	ON
BATTERY LOW	ON
OUT OF RANGE	ON
LANGUAGE	DEUTSCH
TIME FORMAT	24-HR
DATE FORMAT	DD/MM/YY

#### Base station

The default settings can be restored via the menu.  
Refer to Page 92 for the sequence of menu option selections.

RINGER VOLUME	3
DIAL MODE	TONE
FLASH TIME	SHORT
SYSTEM PIN	0000

**1 DECT:** Digital Enhanced Cordless Telecommunication = Standard for cordless telephones.

## Answering machine

ANSWER ON/OFF	ON
ANSWER DELAY	6
MSG ALERT TONE	ON
REMOTE PIN	0000

## Declaration of Conformity

This device fulfils the requirements stipulated in the EU directive:

1999/5/EC directive on radio equipment and telecommunications terminal equipment and the mutual recognition of their conformity. Conformity with the above mentioned directive is confirmed by the CE mark on the device. To view the complete Declaration of Conformity, please refer to the free download available on our web site [www.switel.com](http://www.switel.com).



# Maintenance / Guarantee

---

## 14 Maintenance / Guarantee

### Maintenance

- Clean the housing surfaces with a soft, fluff-free cloth.
- Do not use any cleaning agents or solvents.

### Guarantee

SWITEL equipment is produced and tested according to the latest production methods. The implementation of carefully chosen materials and highly developed technologies ensure trouble-free functioning and a long service life. The terms of guarantee do not apply where the cause of equipment malfunction is the fault of the telephone network operator or any interposed private branch extension system. The terms of guarantee do not apply to the batteries or power packs used in the products. The period of guarantee is 24 months from the date of purchase.

All deficiencies related to material or manufacturing errors within the period of guarantee will be redressed free of charge. Rights to claims under the terms of guarantee are annulled following tampering by the purchaser or third parties. Damage caused as the result of improper handling or operation, normal wear and tear, incorrect positioning or storage, improper connection or installation or Acts of God and other external influences are excluded from the terms of guarantee. In the case of complaints, we reserve the right to repair defective parts, replace them or replace the entire device. Replaced parts or devices become our property. Rights to compensation in the case of damage are excluded where there is no evidence of intent or gross negligence by the manufacturer.

If your device does show signs of a defect within the period of guarantee, please contact the sales outlet where you purchased the SWITEL device, producing the purchase receipt as evidence. All claims under the terms of guarantee in accordance with this agreement can only be asserted at the sales outlet. No claims under the terms of guarantee can be asserted after a period of two years from the date of purchase and hand-over of the product.



## 15 Index

**A**

Alarm, 96  
 Announcement, 96  
 Ans Settings menu, 96  
 Answering machine, 96  
 Answering machine  
   in the telephone network, 90

**B**

Base station, 83, 85  
 Battery charge status, 84  
 Brokering, 89

**C**

Call back, 88, 94  
 Call log, 94  
 Caller number display, 90, 94  
 Charging, 84  
 CLIP, 90  
 Conference calls, 89

**D**

Date, 84  
 Declaration of Conformity, 103  
 Default settings, 102  
 Delay, 96  
 Deleting, 97, 98  
 Deleting messages, 98  
 Deregistration, 95  
 Dialling, 88  
 Dialling pause, 90  
 Display, 86, 98  
 Display icons, 86

**E**

ECO mode, 84  
 Ending a call, 88  
 Energy-save mode, 87  
 Entering names, 93  
 Entering text, 93  
 Extending, 95

**F**

Forwarding calls, 88

**G**

Guarantee, 104

**H**

Handset, 95  
 Handsfree, 89  
 Holding a call, 89

**I**

Icons, 86  
 Inserting the battery pack, 84  
 Internal calls, 88

**K**

Key function assignment, 97, 99

**L**

Low-radiation, 84

**M**

Main menu, 91  
 Maintenance , 104  
 Making a call, 88  
 Maximum recording time , 96  
 Menu structure, 91

Messages, 98  
 Muting, 89  
 Muting button, 89

**N**

Notation, 86

**O**

Operating elements, 85  
 Operating via the base station, 98  
 Operating via the handset, 96  
 Operation, 86

**P**

Package contents, 83  
 Paging, 89  
 Phone book, 88, 93  
 Phone book entries, 87, 93  
 PIN code, 99  
 Playing, 96  
 Playing back, 98  
 Private branch exchanges, 90  
 Problems, 100  
 Problems and solutions, 100

**R**

R function, 90  
 Receiver volume, 89  
 Recording, 96  
 Recording a memo, 97  
 Redialling, 88  
 Registering, 95  
 Remote access, 99  
 Remote activation, 99  
 Replace receiver, 88

**S**

Safety information, 82  
 Save, 87  
 Saving, 93, 94  
 Searching for the handset, 89  
 Service-Hotline, 100  
 Standby mode, 87  
 Starting up, 83  
 Supplementary services, 90  
 Switching off, 89  
 Switching on, 89

**T**

Taking a call, 88  
 Taking a call being recorded, 96  
 Talk time, 89  
 Technical data, 102  
 Telephoning, 88  
 Time, 84  
 Tollsaver, 96  
 Troubleshooting, 100

**V**

VMWI, 90  
 Volume, 98

## Notes

---



# **SWITEL**

## **Declaration of Conformity**

Diese Anlage entspricht der europäischen R&TTE Richtlinie.

Für die komplette Konformitätserklärung nutzen Sie bitte den kostenlosen Download von unserer Website [www.switel.com](http://www.switel.com).

Cet équipement est conforme à la directive européenne R&TTE.

Pour obtenir la déclaration de conformité intégrale, veuillez vous servir du téléchargement gratuit de notre site Internet [www.switel.com](http://www.switel.com).

Quest'apparecchiatura è conforme alla direttiva europea R&TTE.

Per la dichiarazione di conformità completa si prega di voler usufruire del servizio gratuito di download dal nostro sito Internet [www.switel.com](http://www.switel.com).

This equipment complies with the European R&TTE directive.

To view the complete Declaration of Conformity, please refer to the free download available at our web site: [www.switel.com](http://www.switel.com).

---

## **Service Hotline**

Bei technischen Problemen können Sie sich an unsere Service-Hotline unter Tel. 0900 00 1675 innerhalb der Schweiz (Kosten Swisscom bei Drucklegung: CHF 2.60/min) wenden.

S'il s'agit de problèmes techniques, vous pouvez vous adresser à notre hotline de service en Suisse en appelant le numéro 0900 00 1675 (frais Swisscom à la date d'impression de ce manuel : CHF 2.60/min).

In caso di problemi tecnici è possibile rivolgersi alla nostra hotline di assistenza tecnica chiamando al numero 0900 00 1675 valido per la Svizzera (spese da rete Swisscom alla data di stampa: CHF 2.60 / min).

In the event of technical problems, you can contact our hotline service, Tel. 0900 00 1675 within Switzerland (cost via Swisscom at time of going to print: CHF 2.60/min).

