

SWITEL

SWISS BRAND 

**Strahlungsarmes schnurloses
DECT-/GAP-Designtelefon**

**Téléphone de style DECT/GAP
sans fil, à faible rayonnement**

**Telefono senza fili a bassa
radiazione DECT-/GAP**

**Low-radiation, cordless,
design DECT/GAP telephone**



DF 100x

**Bedienungsanleitung
Mode d'emploi
Istruzioni per l'uso
Operating Instructions**

D

F

I

GB

Sicherheitshinweise

1 Sicherheitshinweise

Lesen Sie diese Bedienungsanleitung sorgfältig durch.

Bestimmungsgemäße Verwendung

Dieses Telefon ist geeignet zum Telefonieren innerhalb eines Telefonnetzes. Jede andere Verwendung gilt als nicht bestimmungsgemäß. Eigenmächtige Veränderungen oder Umbauten sind nicht zulässig. Öffnen Sie das Gerät in keinem Fall selbst und führen Sie keine eigenen Reparaturversuche durch.

Aufstellungsort

Vermeiden Sie Belastungen durch Rauch, Staub, Erschütterungen, Chemikalien, Feuchtigkeit, Hitze oder direkte Sonneneinstrahlung.

Verwenden Sie das Mobilteil nicht in explosionsgefährdeten Bereichen.

Netzteil



Achtung: Verwenden Sie nur das mitgelieferte Steckernetzteil, da andere Netzteile das Telefon beschädigen können. Sie dürfen den Zugang zum Steckernetzteil nicht durch Möbel oder andere Gegenstände versperren.

Aufladbare Akkus



Achtung: Werfen Sie Akkus nicht ins Feuer. Verwenden Sie nur Akkus des gleichen Typs! Achten Sie auf die richtige Polung! Bei verkehrter Polung der Akkus besteht beim Aufladen Explosionsgefahr.

Stromausfall

Bei Stromausfall kann mit diesem Telefon nicht telefoniert werden. Halten Sie für Notfälle ein schnurgebundenes Telefon bereit, welches ohne externe Stromversorgung arbeitet.

Medizinische Geräte



Achtung: Benutzen Sie das Telefon nicht in der Nähe von medizinischen Geräten. Eine Beeinflussung kann nicht völlig ausgeschlossen werden.

DECT¹-Telefone können in Hörgeräten einen unangenehmen Brummtönen verursachen.

Hörgeräte-kompatibel

Das Telefon ist mit den meisten am Markt befindlichen Hörgeräten kompatibel. Eine wandfreie Funktion mit jedem Hörgerät kann jedoch nicht garantiert werden.

¹ DECT: Digital Enhanced Cordless Telecommunication = Standard für kabellose Telefone.

Entsorgung

Wollen Sie Ihr Gerät entsorgen, bringen Sie es zur Sammelstelle Ihres kommunalen Entsorgungsträgers (z. B. Wertstoffhof). Das nebenstehende Symbol bedeutet, dass Sie das Gerät auf keinen Fall in den Hausmüll werfen dürfen! Nach dem Elektro- und Elektronikgerätegesetz sind Besitzer von Altgeräten gesetzlich gehalten, alte **Elektro- und Elektronikgeräte** einer getrennten Abfallerfassung zuzuführen.



Akkus entsorgen Sie beim batterievertreibenden Handel sowie bei zuständigen Sammelstellen, die entsprechende Behälter bereitstellen.



Verpackungsmaterialien entsorgen Sie entsprechend den lokalen Vorschriften.

2 Telefon in Betrieb nehmen

Sicherheitshinweise



Achtung: Lesen Sie vor der Inbetriebnahme unbedingt die Sicherheitshinweise in Kapitel 1.

Verpackungsinhalt prüfen

Zum Lieferumfang gehören:

Inhalt	DF 1001-Modell			
	DF 1001	DF 1002 ¹	DF 1003 ¹	DF 1004 ¹
Basisstation mit Netzteil	1	1	1	1
Ladestation mit Netzteil	-	1	2	3
Mobilteil	1	2	3	4
Telefonanschlusskabel	1	1	1	1
Akkus	2	4	6	8
Bedienungsanleitung	1	1	1	1

¹ Unter www.switel.com erfahren Sie, ob dieses Telefonset bereits erhältlich ist.

Telefon in Betrieb nehmen

Basisstation anschließen



Achtung: Stellen Sie die Basisstation mit einem Mindestabstand von 1 m zu anderen elektronischen Geräten auf, da es sonst zu gegenseitigen Störungen kommen kann.

Schließen Sie die Basisstation wie auf der Skizze abgebildet an. Verwenden Sie aus Sicherheitsgründen nur das mitgelieferte Netzteil sowie das beigegefügte Telefonanschlusskabel.

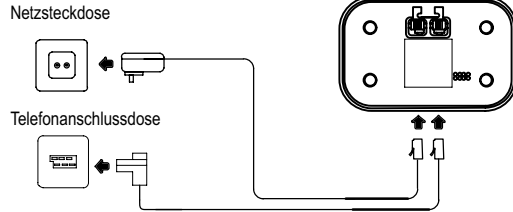

Achtung: Verwenden Sie für die Basis nur das Netzteil mit dem durchsichtigen Stecker und den Werten (Output 7,5 V, 300 mA).

Ladestation anschließen²

Schließen Sie die Ladestation wie auf der Skizze abgebildet an. Verwenden Sie aus Sicherheitsgründen nur das mitgelieferte Netzteil.

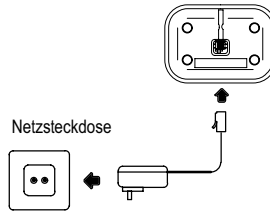

² Gilt nur für Telefonsets mit mindestens zwei Mobilteilen
☞ "Verpackungsinhalt prüfen" auf Seite 2.



Die Basisstation Ihres Telefons ist mit einem energieeffizienten Schaltnetzteil SW-075030EU (Input 100–240 V_{AC}, Output 7,5 V_{DC}, 300 mA) ausgestattet. Die Nulllast beträgt ca. 0,2 W. Die durchschnittliche Effizienz beträgt ca. 67 %. Die Leistungsaufnahme der Basisstation beträgt:

- im Betrieb (Bereitschaft/Gespräch): ca. 1,4 W
- während der Ladung des Mobilteils: ca. 2,2 W

Die mit einem Telefonset gelieferte(n) Ladestation(en) ist/sind mit einem energieeffizienten Schaltnetzteil SW-075020EU (Input 100–240 V_{AC}, Output 7,5 V_{DC}, 200 mA) ausgestattet. Die Nulllast beträgt ca. 0,2 W. Die durchschnittliche Effizienz beträgt ca. 66 %.

Die Leistungsaufnahme der Ladestation beträgt:

- ohne Mobilteil: ca. 0,2 W
- während der Ladung des Mobilteils: ca. 1,1 W

Akkus einlegen

Öffnen Sie das Akkufach. Legen Sie die Akkus in das geöffnete Akkufach ein. Verwenden Sie nur Akkus des Typs AAA NiMH 1,2 V. Achten Sie auf die richtige Polung! Schließen Sie das Akkufach.

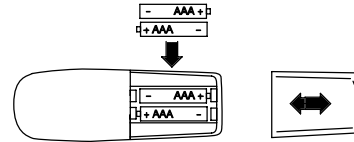

Akkus aufladen



Stellen Sie das Mobilteil bei der ersten Inbetriebnahme für **mindestens 15** Stunden in die Basisstation / Ladestation.

Haben Sie das Mobilteil richtig in die Basisstation / Ladestation gestellt, ertönt ein Hinweissignal und es leuchtet die Ladekontrollleuchte. Das Mobilteil erwärmt sich beim Laden. Dies ist normal und ungefährlich. Laden Sie das Mobilteil nicht mit fremden Aufladegeräten. Der aktuelle **Akkuladestatus** wird im Display angezeigt:



Voll



Halbvoll



Leer

Displaysprache einstellen

Wählen Sie die entsprechende Sprache aus (siehe "Menüstruktur" auf Seite 10):

Menü > Mobilteil-Einst. > Sprache > ...

Bedienelemente

Datum und Uhrzeit des Mobilteils einstellen

Datum und Uhrzeit stellen Sie über das Menü ein. Auf Seite 12 finden Sie die Position im Menü.

Automatische Anrufannahme (Auto-Talk)

Haben Sie diese Funktion aktiviert, wird ein Anruf automatisch beim Herausnehmen des Mobilteils aus der Basisstation angenommen. Die automatische Anrufannahme wird über das Menü aktiviert oder deaktiviert. Auf Seite 13 finden Sie die Position im Menü.

Nebenstellenanlagen

Auf Seite 9 erhalten Sie weitere Informationen, falls Sie Ihr Telefon an eine Nebenstellenanlage anschließen möchten.

Strahlungsreduzierung (ECO-Mode)

Die Strahlung wird im Vergleich zu Standard-DECT-Schnurlostelefonen im Bereitschaftsmodus erheblich verringert (wenn das Mobilteil in der Basis steht).

Im Gesprächsmodus wird die Strahlung abhängig von der Entfernung des Mobilteils zur Basis verringert.



Werkseinstellung = Einstellungen → Basis-Einstell. → ECO-Modus → Aus

Sie können das Telefon so einstellen, dass die Strahlung reduziert wird  Seite 13.









Bei Bedarf können Sie die Reichweite des Telefonsystems erhöhen, indem Sie den ECO-Mode ausschalten.



3 Bedienelemente

Die Tasten Ihres Telefons werden in dieser Bedienungsanleitung nachfolgend mit vereinheitlichten umrandeten Symbolen dargestellt. Leichte Abweichungen der Tastensymbole Ihres Telefons gegenüber den hier verwendeten Tastensymbolen sind daher möglich.

Mobilteil

- 1 Hörer
- 2 Display
- 3 Softkey-Taste rechts
- 4  Navigation aufwärts / Wahlwiederholung
- 5  Auflegen-Taste
- 6  #-Taste / Tastensperre
- 7  Intern telefonieren
- 8 Mikrofon
- 9  R -Taste
- 10  *-Taste / Temporäre Tonwahl
- 11  Gesprächstaste / Freisprechen
- 12  Navigation abwärts / Telefonbuch
- 13 Softkey-Taste links
- 14 Lautsprecher (auf der Rückseite)

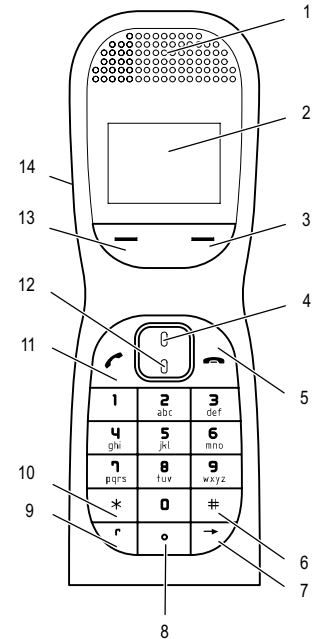

Basisstation

- 1 Ladekontakte
- 2 Mobilteil suchen (Paging)
- 3 LED: Ladeanzeige

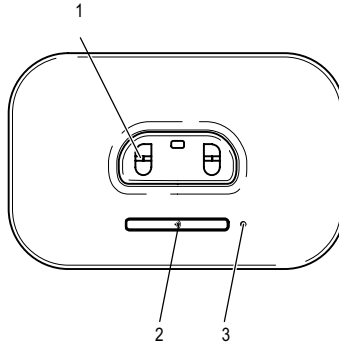

Ladestation¹

- 1 Ladekontakte
- 2 LED: Ladeanzeige

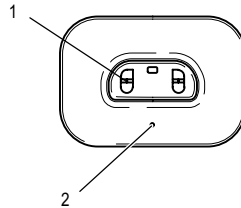

4 Einführende Informationen

In diesem Kapitel finden Sie grundlegende Informationen zur Handhabung der Bedienungsanleitung und des Telefons.











Darstellungsweise in der Bedienungsanleitung

Darstellung	Beschreibung
	Darstellung von Tasten
	Abgebildete Taste kurz drücken
3 Sek.	Abgebildete Taste 3 Sekunden drücken
halten	Abgebildete Taste halten
loslassen	Abgebildete Taste loslassen
	Nummern oder Buchstaben eingeben
	Mobilteil klingelt
	Basisstation klingelt
	Mobilteil aus der Basisstation nehmen
	Mobilteil in die Basisstation stellen
	Darstellung von Display-Texten
	Darstellung von Display-Symbolen
	Softkey-Taste drücken Seite 6

¹ Gilt nur für Telefonsets mit mindestens zwei Mobilteilen
 "Verpackungsinhalt prüfen" auf Seite 2.

Einführende Informationen

Symbole und Texte im Display des Mobilteils

Symbol	Beschreibung
	Anzeige der Akkukapazität
	Alarmpunktion aktiviert
	Klingellautstärke = Aus
	Es sind neue Anrufe in der Anruferliste ☞ Seite 15.
	Das Freisprechen ist aktiviert ☞ Seite 8.
	Die Tastensperre ist aktiviert ☞ Seite 9.
	Anrufbeantworter im Telefonnetz. VMWI ¹ - Zusatzdienst Ihres Netzbetreibers ☞ Seite 9.
<input type="checkbox"/> Stumm ein	Das Mikrofon ist stummgeschaltet ☞ Seite 9.
	Konstant: Die Verbindung zur Basisstation ist gut. Blinkend: Die Verbindung zur Basisstation bricht ab. Nähern Sie sich der Basisstation.
	Der Anrufbeantworter ist eingeschaltet.
	Es sind neue Nachrichten auf dem Anrufbeantworter.

Bereitschaftsmodus

Alle Beschreibungen in dieser Bedienungsanleitung gehen davon aus, dass sich das Mobilteil im Bereitschaftsmodus befindet. Den Bereitschaftsmodus erreichen Sie, indem Sie die Taste  drücken.

Energiesparmodus

Nach einiger Zeit im Bereitschaftsmodus wechselt das Mobilteil in den Energiesparmodus. Tasten und Display sind nun nicht mehr beleuchtet. Drücken Sie die Taste , um den Bereitschaftsmodus zu aktivieren.

Navigationsstasten

Die Softkey-Tasten (1) und (6) sind in den verschiedenen Menüs mit unterschiedlichen Funktionen belegt. Sie sind in dieser Bedienungsanleitung immer nach den darüber liegenden Texten im Display benannt.

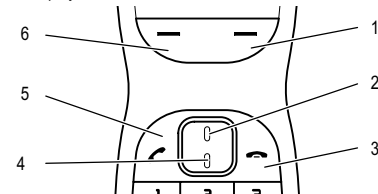







Taste	Im Bereitschaftsmodus	Im Menü
1	- Telefonbuchmenü öffnen	- Navigation zurück
2	- Wahlwiederholungsliste öffnen	- Navigation aufwärts
3	- Mobilteil ein- und ausschalten	- In den Bereitschaftsmodus wechseln / Vorgänge abbrechen
4	- Telefonbuch öffnen	- Navigation abwärts
5	- Gesprächstaste / Freisprechen	
6	- Hauptmenü öffnen	- Navigation weiter

¹ VMWI: Visual Message Waiting Indication = Optische Anzeige neuer Nachrichten.

Navigation im Menü

Alle Funktionen sind über unterschiedliche Menüs zu erreichen.
Den Weg zur gewünschten Funktion entnehmen Sie der Menüstruktur  Seite 10.







Menü	Hauptmenü öffnen
 /  SMS	Gewünschtes Untermenü auswählen
Wählen	Untermenü öffnen
 /  SMS schreiben	Gewünschte Funktion auswählen
Wählen	Funktion öffnen
	Über Tastenfeld Nummern oder Buchstaben eingeben
Option	Eingaben bestätigen
Zurück	Eine Ebene zurück
	Programmier- und Speichervorgänge abbrechen und in den Bereitschaftsmodus zurückkehren



Jeder Vorgang wird automatisch abgebrochen, wenn innerhalb von 30 Sekunden keine Eingabe erfolgt.

Telefonbucheinträge erstellen - Beispiel

Wie Sie in den Menüs navigieren und Einstellungen vornehmen, ist hier anhand des Beispiels **Telefonbucheinträge erstellen** erklärt. Verfahren Sie bei allen Einstellungen wie in diesem Beispiel.

Namen	Telefonbuch öffnen
 /  Eintrag hinzuf.	Untermenü auswählen und bestätigen
Wählen	bestätigen
Name eingeben: 	Namen eingeben (max. 12 Stellen) und bestätigen
OK	
Nummer eingeben: 	Rufnummer eingeben (max. 24 Ziffern) und bestätigen
Speichern	bestätigen
 / 	Ruftonmelodie auswählen und bestätigen
Wählen	bestätigen

5 Telefonieren

Anruf annehmen

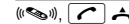

Anruf annehmen

Gespräch beenden



Gespräch beenden

Anrufen



Rufnummer eingeben (max. 24 Ziffern)

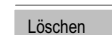

Bei Falscheingabe letzte Ziffer löschen



Rufnummer wählen



Sie können auch zuerst die Gesprächstaste drücken und erhalten damit das Freizeichen. Die eingegebenen Ziffern Ihrer gewünschten Rufnummer werden sofort gewählt. Eine Korrektur einzelner Ziffern der Rufnummer ist bei dieser Form des Gesprächsaufbaus nicht möglich.

Telefonieren

Wahlwiederholung

Ihr Telefon speichert die 20 zuletzt gewählten Rufnummern in einer Wahlwiederholungsliste.

	Wahlwiederholungsliste öffnen
/ ,	Eintrag auswählen und Verbindung herstellen

Eingegangene Anrufe zurückrufen

Ihr Telefon speichert 30 Anrufe in einer Anruferliste.

Menü , /	
Anruflisten , Wählen	Anruferlistenmenü öffnen
Verpasste Anrufe oder Angenomm. Anrufe ,	
Wählen	Anruferliste öffnen
/ ,	Eintrag auswählen und Verbindung herstellen

Rufnummern aus dem Telefonbuch wählen

Sie müssen Rufnummern im Telefonbuch gespeichert haben

Seite 7 und 15.

	Telefonbuch öffnen
/ ,	Eintrag auswählen und Verbindung herstellen

Intern telefonieren¹

Interne Gespräche führen

Sie müssen zwei oder mehr Mobilteile (MT1, MT2, ...) an Ihrer Basisstation angemeldet haben, um interne kostenlose Gespräche führen zu können.

MT1: , z. B. , OK	Interne Rufnummer des gewünschten Mobilteils wählen
MT2:	Internes Gespräch am anderen Mobilteil annehmen
MT1 / MT2:	Internes Gespräch beenden

Externe Gespräche intern weiterleiten

MT1: , z. B. , OK	Während des externen Gesprächs interne Rufnummer wählen
---------------------	---

¹ Das interne Telefonieren ist nur mit mindestens zwei Mobilteilen möglich "Verpackungsinhalt prüfen" auf Seite 2.

MT2:	Internes Gespräch am anderen Mobilteil annehmen
MT1:	Gespräch weiterleiten
	Sollte sich das gerufene Mobilteil nicht melden, können Sie sich das externe Gespräch zurückholen, indem Sie die Tas-te drücken.

Rücksprache / Makeln

Während eines externen Gesprächs können Sie ein anderes Mobilteil anwählen, um Rücksprache zu halten. Der externe Gesprächspartner wird gehalten, während Sie mit dem internen Gesprächspartner sprechen. Diesen Vorgang können Sie beliebig oft wiederholen.

MT1: , z. B. , OK	Während des externen Gesprächs interne Rufnummer wählen
MT2:	Internes Gespräch am anderen Mobilteil annehmen
MT1:	Gesprächspartner wechseln

Konferenzgespräche führen

Ein externes Gespräch kann mit einem weiteren internen Gesprächspartner zum Konferenzgespräch geschaltet werden.

MT1: , z. B. , OK	Während des externen Gesprächs interne Rufnummer wählen
MT2:	Internes Gespräch am anderen Mobilteil annehmen
MT1	Konferenz starten
MT1 / MT2:	Konferenz beenden

Einstellen der Hörerlautstärke

Sie können während eines Gesprächs die Lautstärke in 8 Stufen anpassen.

/	Gewünschte Lautstärke auswählen
---	---------------------------------

Freisprechen

Nutzen Sie diese Funktion, um den Gesprächspartner über den Lautsprecher zu hören.

	Freisprechen einschalten
	Freisprechen ausschalten

Anzeige der Gesprächsdauer

Während eines Gesprächs wird die Gesprächsdauer in Minuten und Sekunden angezeigt.



Mikrofon im Mobilteil stummschalten

Sie können während eines Telefongesprächs das Mikrofon des Mobilteils aus- und einschalten.

	Mikrofon ausschalten (stummschalten)
	Mikrofon einschalten

Tastensperre



Die Tastensperre soll verhindern, dass versehentlich Funktionen ausgelöst werden.

3 Sek. 	Tastensperre einschalten
Entsp. 	Tastensperre ausschalten

 Bei eingeschalteter Tastensperre können eingehende Anrufe wie gewohnt angenommen werden.



Mobilteil suchen (Paging)

Wenn Sie Ihr Mobilteil verlegt haben, können Sie es über einen Suchton leicht wiederfinden.

	Suchton starten
 oder 	Suchton beenden

Mobilteil aus- und einschalten

Um die Akkus zu schonen, können Sie das Mobilteil ausschalten.

3 Sek. 	Mobilteil ausschalten
3 Sek. 	Mobilteil einschalten

6 Nebenstellenanlagen / Zusatzdienste

R-Funktion an Nebenstellenanlagen

Ist Ihr Telefon an einer Nebenstellenanlage angeschlossen, können Sie über die Taste  Funktionen, wie z. B. Anrufe weiterleiten und automatischen Rückruf, nutzen. Lesen Sie bitte in der Bedienungsanleitung Ihrer Nebenstellenanlage, welche Flash-Zeit Sie zur Nutzung dieser Funktionen einstellen müssen. Ob Ihr Telefon an Ihrer Nebenstellenanlage einwandfrei funktioniert, erfahren Sie bei dem Händler, bei dem die Anlage gekauft wurde. Die Flash-Zeit stellen Sie über das Menü ein. Auf Seite 13 finden Sie die Position (Rückruf-Modus) im Menü.

¹ CLIP: Calling Line Identification Presentation = Anzeige der Rufnummer eines Anrufers.

R-Funktion und Zusatzdienste

Ihr Telefon unterstützt Zusatzdienste Ihres Netzbetreibers, wie z. B. Makeln, Anklopfen und Konferenz. Über die Taste  können Sie diese Zusatzdienste nutzen. Bitte fragen Sie Ihren Netzbetreiber, welche Flash-Zeit Sie zur Nutzung von Zusatzdiensten einstellen müssen. Zur Freischaltung von Zusatzdiensten wenden Sie sich bitte an Ihren Netzbetreiber. Die Flash-Zeit stellen Sie über das Menü ein. Auf Seite 13 finden Sie die Position (Rückruf-Modus) im Menü.

Rufnummernanzeige (CLIP¹)



Die Rufnummernanzeige ist ein Zusatzdienst Ihres Netzbetreibers. Fragen Sie Ihren Netzbetreiber nach weiteren Informationen.

Wenn diese Funktion an Ihrer Telefonleitung zur Verfügung steht, wird Ihnen bereits die Rufnummer des Anrufers angezeigt, wenn das Telefon klingelt. Hat der Anrufer das Übertragen seiner Rufnummer unterdrückt, wird eine entsprechende Meldung angezeigt. Die Rufnummer kann nicht angezeigt und somit auch nicht in der Anruferliste gespeichert werden.

Wahlpause

Bei Nebenstellenanlagen ist es erforderlich, eine Amtskennzahl vorzuwählen, um ein Freizeichen zu bekommen. Bei wenigen älteren Nebenstellenanlagen dauert es einige Zeit, bis das Freizeichen zu hören ist. Für diese Nebenstellenanlagen kann nach der Amtskennzahl eine Wahlpause eingefügt werden, um direkt weiterwählen zu können, ohne das Freizeichen abzuwarten.

3 Sek.  Wahlpause einfügen

Nach der Amtskennzahl erfolgt die Wahl der eigentlichen Rufnummer nach einer bestimmten Zeit.



Die Wahlpause kann auch bei der Eingabe von Rufnummern im Telefonbuch gespeichert werden.

Anrufbeantworter im Telefonnetz

Der Anrufbeantworter im Telefonnetz ist ein Zusatzdienst vieler Netzbetreiber. Wenn Ihr Netzbetreiber einen Anrufbeantworter im Telefonnetz für Sie bereitstellt, werden Sie mit einem Symbol über neue Nachrichten informiert (**VMWI**²). Über diese Funktion können Sie nur dann verfügen, wenn Ihr Netzbetreiber diesen Zusatzdienst anbietet. Bitte fragen Sie Ihren Netzbetreiber nach weiteren Informationen.

² VMWI: Visual Message Waiting Indication = Optische Anzeige neuer Nachrichten.

Menüstruktur

7 Menüstruktur

Hauptmenü

In das Hauptmenü gelangen Sie durch Drücken der Softkey-Taste **Menü** . Wie Sie sich im Menü bewegen und Eingaben vornehmen, zeigt Ihnen Seite 6.

SMS	SMS schreiben		Option	Senden	Nummer eingeben:	Senden
	Eingang	Lesen	Option	Speichern		
				Symbol einfügen		
				Smiley einfügen		
				Vorlage einfügen		
	Entwürfe	Ändern	Option	Antworten		
				Weiterleiten		
				SMS-Details		
				Nr. verwenden		
				Löschen		
	Ausgang	Lesen	Option	siehe SMS schreiben		
				Weiterleiten		
	Vorlagen	Option	Ändern	Löschen	Ja / Nein	
	Nachr. löschen	Eingang	Löschen	Ja / Nein		
		Entwürfe	Ja / Nein			
		Ausgang	Ja / Nein			
		Alle Nachrichten	Ja / Nein			
SMS-Einstellungen	Servicezentren	Zentrum einstell.		Sendezentrum 1		

		Sendezentrum 2		
	Empfangszentren	Empfangszentr. 1 - 2	Nummer eingeben: ☰☱☲☳	Speichern
	Sendezentren	Sendezentrum 1 - 2	Nummer eingeben: ☰☱☲☳	Speichern
Mailbox-Nummer	☰☱☲☳	Speichern		
Nachrichtengröße	160 Zeichen			
	612 Zeichen			
Nachrichthinweis	Ein / Aus			
Benutzer	Benutzer 1 - 4	Option	Ändern	Name eingeben: ☰☱☲☳
			Löschen	Ja / Nein

Anruflisten	Verpasste Anrufe	Option	Details anzeigen	
			Nr. speichern	Name eingeben: ☰☱☲☳
				Nummer eingeben: ☰☱☲☳
			Nachricht senden	☰☱☲☳
			Anruf löschen	
	Angenomm. Anrufe	Option	siehe Verpasste Anrufe	
	Gewählte Nr.	Option	siehe Verpasste Anrufe	
	Anrufe löschen	Verpasste Anrufe, Angenomm. Anrufe, Gewählte Nr.		Ja / Nein





Agenda	Option	Ereignis hinzuf. ☰☱☲☳	Datum eingeben: ☰☱☲☳	Uhrz. eingeben: ☰☱☲☳	Stumm	
					Hinweissignal	Einmal / Jährlich
		Details anzeigen				
		Ereignis ändern ☰☱☲☳	Datum eingeben: ☰☱☲☳	Uhrz. eingeben: ☰☱☲☳	Stumm	
					Hinweissignal	Einmal / Jährlich
	Als Text senden	Option	Senden	Nummer eingeben: ☰☱☲☳	Senden	

Menüstruktur



		Speichern
		Symbol einfügen
		Smiley einfügen
		Vorlage einfügen
Ereignis löschen	Ereignis löschen?	Ja / Nein
Ereignisse lösch.	Alle Ereignisse löschen?	Ja / Nein

Uhrzeit & Alarm	Datum & Uhrzeit	Datum eingeben:	Uhrz. eingeben:
	Wecker	Aus / Ein	
	Zeitformat	12-Stunden	
		24-Stunden	

Einstellungen	Mobilteil-Einst.	Klingelton	Externer Anruf	Melodie 1 - 20
			Interner Anruf	Melodie 1 - 20
		Ruftonlautstärke	Rufton aus	
			Lautst. 1 - 5	
		Hörerlautstärke	Lautst. 1 - 8	
		Mobilteil-Name		
		Sprache	English (UK)	
			Français	
			Deutsch	
			Italiano	
			Español	
		Bildschirmschoner	Uhr / Aus	

Basis-Einstell.	Beleuchtung	15 Sekunden		
		30 Sekunden		
		45 Sekunden		
	Auto-Talk	Aus / Ein		
	Tastenton	Aus / Ein		
	Nebenst.-Vorw.	Aus / Ein		
		Code einstellen		
	Klingelton	Melodie 1 - 5		
		Standard-Rufton		
	Ruftonlautstärke	Rufton aus		
		Lautst.		
	Wählmodus	Impulswahl		
		Tonwahl		
Rückruf-Modus	R-Taste 1			
	R-Taste 2			
Erster Rufton	Ein / Aus			
System-PIN	Alte PIN eingeb.: 	Neue PIN eingeb.: 	PIN erneut eing.: 	
Alles zurücksetzen	Sind Sie sicher?	Ja / Nein	System-PIN eing.: 	
ECO-Modus	Aus / Ein			

D

Anmeldung	Mobilt. anmelden	Basis 1 - 4	System-PIN eing.: 
	Basis auswählen	Basis 1 - 4	System-PIN eing.: 
	Abmelden		

Menüstruktur

Namen	Option	Details anzeigen		
	Nachricht senden	Option	Senden	Nummer eingeben:
			Speichern	
			Symbol einfügen	
			Smiley einfügen	
			Vorlage einfügen	
	Eintrag ändern	Name eingeben:	Nummer eingeben:	Melodie 1 - 20
				Standard-Rufton
	Eintrag kopieren	Zu MT oder BS		
	Klingelton	Melodie 1 - 20		
		Standard-Rufton		
	Eintrag löschen	Ja / Nein		
	Schnelwahl	Taste 1 - 3	Zuweisen	
			Eingabe löschen	
	Eintrag hinzuf.	Name eingeben:	Nummer eingeben:	Melodie 1 - 20
				Standard-Rufton
	Telefonbuch kop.	Zu MT oder BS		
	Speicherstatus			
	Telefonb. löschen	Alle Einträge löschen?	Ja / Nein	

8 Telefonbuch

Im Telefonbuch können Sie 250 Rufnummern mit den dazugehörigen Namen speichern.

- Die Telefonbucheinträge sind alphabetisch geordnet. Um direkt zum gewünschten Telefonbucheintrag zu gelangen, drücken Sie den entsprechenden Anfangsbuchstaben.

Namen eingeben

Die Zifferntasten sind mit Buchstaben beschriftet. Durch mehrmaliges Drücken der entsprechenden Taste können Buchstaben, Ziffern und Sonderzeichen eingegeben werden.

Leerzeichen eingeben

Löschen Löschen

oder Sonderzeichen eingeben



Um den gleichen Buchstaben zweimal einzugeben, drücken Sie die entsprechende Taste. Warten Sie, bis der Cursor eine Stelle weitergesprungen ist. Geben Sie den Buchstaben erneut ein.

Telefonbucheinträge erstellen

Siehe Beispiel Seite 7.

Telefonbucheinträge ändern

Namen Hauptmenü öffnen

/ Öffnen , Telefonbuch auswählen

Wählen und bestätigen

/ , Option Telefonbucheintrag auswählen und bestätigen

/ Eintrag ändern , Untermenü auswählen und bestätigen

Name eingeben: , OK Namen ändern und bestätigen

Nummer eingeben: , Rufnummer ändern und

Speichern bestätigen

Melodie 1 - 20 Rufmelodie auswählen und

Wählen speichern

¹ **CLIP**: Calling Line Identification Presentation = Anzeige der Rufnummer eines Anrufers.

Telefonbucheinträge löschen

Einen Eintrag löschen

Namen Hauptmenü öffnen

/ Öffnen , Telefonbuch auswählen

Wählen und bestätigen

/ , Option Telefonbucheintrag auswählen und bestätigen

/ Eintrag löschen , Untermenü auswählen und bestätigen

Löschen ? , Ja / Nein Löschvorgang bestätigen oder abbrechen

Alle Einträge löschen

Namen Hauptmenü öffnen

/ Telefonb. löschen , Untermenü auswählen und

Wählen bestätigen

Alle Einträge löschen? , Löschvorgang

Ja / Nein bestätigen oder abbrechen

9 Anruferliste

Insgesamt werden 30 Rufnummern in einer Anruferliste gespeichert.



Die Rufnummernanzeige (**CLIP**¹) ist ein Zusatzdienst Ihres Netzbetreibers. Ihr Telefon zeigt die Rufnummern im Display, wenn Ihr Netzbetreiber diesen Service anbietet. Bitte fragen Sie Ihren Netzbetreiber nach weiteren Informationen.

Rufnummern aus der Anruferliste anzeigen/anrufen

Menü Hauptmenü öffnen

/ Anruflisten , Untermenü auswählen und

Wählen bestätigen

Verpasste Anrufe oder Angenomm. Anrufe ,

Wählen Anruferliste öffnen

Besondere Funktionen



Rufnummer wählen

Rufnummer aus der Anruferliste im Telefonbuch speichern

Eine Rufnummer kann direkt aus der Anruferliste im Telefonbuch gespeichert werden.

Menü	Hauptmenü öffnen
▼ / ▲ Anruflisten	Untermenü auswählen und bestätigen
Wählen	bestätigen
Verpasste Anrufe oder Angenomm. Anrufe	Anruferliste öffnen
Wählen	Anruferliste öffnen
▼ / ▲ Option	Eintrag auswählen und bestätigen
Nr. speichern	Funktion öffnen
Wählen	Funktion öffnen
Name eingeben: , OK	Namen eingeben (max. 12 Stellen) und bestätigen
Nummer eingeben: ,	Rufnummer anpassen und bestätigen
Speichern	und bestätigen
Melodie 1 - 20	Ruftonmelodie auswählen und speichern
Wählen	speichern

Rufnummern aus der Anruferliste löschen

Einzelne Rufnummer löschen

Menü	Hauptmenü öffnen
▼ / ▲ Anruflisten	Untermenü auswählen und bestätigen
Wählen	bestätigen
Verpasste Anrufe oder Angenomm. Anrufe	Anruferliste öffnen
Wählen	Anruferliste öffnen
▼ / ▲ Option	Eintrag auswählen und bestätigen
Anruf löschen	Funktion bestätigen
Wählen	Funktion bestätigen

Alle Rufnummern löschen

Menü	Hauptmenü öffnen
▼ / ▲ Anruflisten	Untermenü auswählen und bestätigen
Wählen	bestätigen
▼ / ▲ Anrufe löschen	Untermenü öffnen
Verpasste Anrufe oder Angenomm. Anrufe oder Gewählte Nr. oder Alle Anrufe	Anruferliste wählen
Wählen	Anruferliste wählen
Alle Anrufe löschen?	Löschvorgang
Ja / Nein	bestätigen oder abbrechen

10 Besondere Funktionen

Wahlverfahren

Sie können Ihr Telefon sowohl an den analogen Vermittlungsstellen (Impuls-Wahlverfahren) als auch an den neuen digitalen Vermittlungsstellen (Ton-Wahlverfahren) betreiben. Das Wahlverfahren wird über das Menü eingestellt. Auf Seite 13 finden Sie die Position im Menü.

Temporäre Tonwahl

Können Sie Ihr Telefon nur mit dem Impuls-Wahlverfahren betreiben, brauchen Sie nicht auf die Vorteile des Ton-Wahlverfahrens (z. B.: Abfrage eines Anrufbeantworters im Telefonnetz) zu verzichten. Während einer bestehenden Verbindung können Sie vorübergehend zum Ton-Wahlverfahren wechseln.

1 Sek. * Während des Gesprächs drücken

Nach Gesprächsende wird wieder automatisch auf das Impuls-Wahlverfahren zurückgeschaltet.

Alarm

Mit dieser Funktion können Sie sich zu einer bestimmten Zeit von Ihrem Mobilteil wecken lassen. Auf Seite 12 finden Sie die Position im Menü.

Agenda

Sie können in Ihrem Telefon bis zu 5 Einträge (z. B. Geburtstage) eintragen, um am entsprechenden Tag erinnert zu werden. Die Einträge können bis zu 24 Zeichen haben.

Agendaeinträge erstellen

Menü	Hauptmenü öffnen
------	------------------

<input type="button" value="v"/> / <input type="button" value="^"/> <input type="text" value="Agenda"/>	Agenda auswählen
<input type="button" value="Wählen"/>	und bestätigen
<input type="button" value="Option"/> <input type="text" value="Ereignis hinzuf."/>	Auswählen
<input type="button" value="Wählen"/>	und bestätigen
<input type="button" value="Speichern"/>	Betreff eingeben und bestätigen
<input type="button" value="Speichern"/>	Datum eingeben und bestätigen
<input type="button" value="Speichern"/>	Uhrzeit eingeben und bestätigen
<input type="button" value="v"/> / <input type="button" value="^"/> <input type="text" value="Stumm"/>	oder
<input type="text" value="Hinweissignal"/> <input type="button" value="Wählen"/>	Erinnerungsart auswählen und bestätigen
Wenn Sie <input type="text" value="Hinweissignal"/> gewählt haben:	
<input type="button" value="v"/> / <input type="button" value="^"/> <input type="text" value="Einmal"/>	oder
<input type="text" value="Jährlich"/> <input type="button" value="Wählen"/>	Intervall auswählen und bestätigen
<input type="button" value="v"/> / <input type="button" value="^"/> <input type="text" value="Beim Ereignis"/>	oder
<input type="text" value="30 Min. vorher"/> <input type="button" value="Wählen"/>	Erinnerungszeitpunkt auswählen und bestätigen

Weitere Bedienschritte entnehmen Sie der Menüstruktur auf Seite 30.

11 SMS

SMS-Voraussetzungen

Ihr Telefonanschluss muss über das Leistungsmerkmal **CLIP**¹ verfügen. Vergewissern Sie sich bei Ihrem Netzbetreiber, dass dieses Leistungsmerkmal für Ihren Telefonanschluss freigeschaltet ist. Um den **SMS**²-Dienst zu nutzen, muss dieser von Ihrem Netzbetreiber aktiviert werden.

- Nicht von jeder Nebenstellenanlage können SMS versandt werden.



Wenn Sie von einer Nebenstellenanlage SMS versenden möchten, speichern Sie vor den Service-Center-Nummern in Ihrem Mobilteil die Amtskennziffer Ihrer Nebenstellenanlage ein.

- Bei Call-by-Call-Verbindungen ist der SMS-Versand derzeit nicht möglich.

¹ **CLIP**: Calling Line Identification Presentation = Anzeige der Rufnummer eines Anrufers.

² **SMS**: Short Message Service = Dienst für das Versenden von Kurznachrichten.

- Das Senden von SMS-Nachrichten ist kostenpflichtig.
- Nutzt der Empfänger im Festnetz keinen SMS-Dienst oder kann sein Telefon generell keine SMS empfangen, wird die SMS automatisch als Sprachmeldung zugestellt.
- Die Kostenberechnung erfolgt über Ihren Netzbetreiber.

SMS-Service-Center

Die Verteilung von SMS-Nachrichten erfolgt über ein Service-Center. Wenn Sie SMS-Textnachrichten versenden möchten, müssen Sie eine Service-Center-Nummer in Ihr Mobilteil einprogrammieren Seite 11. Bitte erfragen Sie beim Anbieter Ihrer Wahl die erforderliche Service-Center-Nummer und die Vorgehensweise zur Freischaltung des SMS-Dienstes.



Ihr Telefon ist zum Versenden von SMS-Textnachrichten vorbereitet. Es sind bereits SMS-Center-Nummern in Ihrem Mobilteil einprogrammiert. Aktivieren Sie das gewünschte SMS-Center im SMS-Menü Seite 11.

Sendezentrum 1

Sendezentrum 2

Swisscom: 0622100000

Cablecom: 0435375370

Text eingeben

Zur Eingabe von Text sind die Ziffern-Tasten mit Buchstaben beschriftet. Durch mehrmaliges Drücken der entsprechenden Taste können Buchstaben, Ziffern und Sonderzeichen eingegeben werden. Die Navigation, wie Sie eine SMS schreiben können, entnehmen Sie der Menüstruktur Seite 10.



Zwischen Groß- und Kleinschreibung umschalten

Letzte Stelle löschen

3 Sek.

Alles Löschen

SMS-Textvorlagen

Es stehen 5 vorprogrammierte Textvorlagen zur Verfügung Seite 10.

SMS-Hinweissignal (Alarm)

Wenn Sie neue SMS-Textnachrichten empfangen haben, werden Sie mit einem Hinweissignal darauf aufmerksam gemacht. Das Signal wird über das Menü aktiviert oder deaktiviert. Auf Seite 11 finden Sie die Position im Menü.

Erweitern des Telefonsystems

12 Erweitern des Telefonsystems

Über den international genormten **GAP**¹-Standard ist die Kompatibilität von Mobilteilen und Basisstationen unterschiedlicher Hersteller geregelt. So ist es möglich, SWITEL-Geräte und Geräte anderer Hersteller zusammen in ein Telefonsystem zu integrieren. Es ist jedoch möglich, dass einige Funktionen nicht zur Verfügung stehen.

Mehrere Mobilteile

Sie können insgesamt 5 Mobilteile an Ihre Basisstation anmelden.

Anmelden von Mobilteilen

Bevor Sie ein Mobilteil anmelden, müssen Sie die Basisstation in den Registriermodus setzen. Halten Sie die Paging-Taste an der Basis gedrückt, bis Sie einen Signalton hören. Jetzt ist die Basis für 60 Sekunden im Registriermodus. Fahren Sie am Mobilteil fort. 2 Sek.  Registriermodus starten

Melden Sie nun das Mobilteil an  Seite 13. Benutzen Sie zur Anmeldung den aktuell eingestellten PIN-Code  Seite 13.

Nach dem Anmelden wird dem Mobilteil eine interne Rufnummer zugeteilt.

 Um Mobilteile anderer Hersteller anzumelden, lesen Sie bitte deren Bedienungsanleitungen.

Abmelden von Mobilteilen

 Jedes Mobilteil kann andere an dieser Basisstation angemeldete Mobilteile abmelden.

Mobilteile werden über das Menü abgemeldet. Auf Seite 13 finden Sie die Position im Menü.

Mehrere Basisstationen

Sie können die Reichweite Ihres Mobilteils vergrößern, wenn Sie es an mehrere Basisstationen anmelden. Es kann gleichzeitig an 4 verschiedenen Basisstationen angemeldet sein. Jede Basisstation benötigt eine eigene Telefonsteckdose. Es können Anschlüsse mit derselben und auch mit unterschiedlichen Rufnummern sein.

 Laufende Gespräche können nicht von einer zur anderen Basisstation übertragen werden.



¹ **GAP**: Generic Access Profile = Standard für das Zusammenwirken von Mobilteilen und Basisstationen unterschiedlicher Hersteller.

13 Falls es Probleme gibt

Service-Hotline

Haben Sie Probleme mit Ihrem Telefon, kontrollieren Sie zuerst die folgenden Hinweise. Bei technischen Problemen können Sie sich an unsere Service-Hotline unter Tel. 0900 00 1675 innerhalb der Schweiz (Kosten Swisscom bei Drucklegung: CHF 2.60/min) wenden. Bei Garantieansprüchen wenden Sie sich an Ihren Fachhändler. Die Garantiezeit beträgt 2 Jahre.

Fragen und Antworten

Fragen	Antworten
Keine Verbindung zur Basisstation möglich	<ul style="list-style-type: none">- Prüfen Sie, ob Sie sich mit dem richtigen PIN-Code an der Basisstation angemeldet haben  Seite 13.
Kein Telefongespräch möglich	<ul style="list-style-type: none">- Das Telefon ist nicht korrekt angeschlossen oder gestört. Verwenden Sie nur das mitgelieferte Telefonanschlusskabel.- Testen Sie mit einem anderen Telefon, ob Ihr Telefonanschluss in Ordnung ist.- Das Netzteil ist nicht eingesteckt oder es liegt ein totaler Stromausfall vor.- Das aufladbare Akkupack ist leer oder defekt.- Sie haben sich zu weit von der Basisstation entfernt.- Wahlverfahren falsch eingestellt  Seite 13.
Verbindung abgehackt, fällt aus	<ul style="list-style-type: none">- Sie haben sich zu weit von der Basisstation entfernt.- Falscher Aufstellungsort der Basisstation.
Das System reagiert nicht mehr	<ul style="list-style-type: none">- Setzen Sie alle Funktionen über "Alles zurücksetzen" in den Werkszustand zurück  Seite 13.- Ziehen Sie kurzzeitig das Netzteil aus der Steckdose.

Technische Eigenschaften

Die Akkus sind in kürzester Zeit leer	<ul style="list-style-type: none"> - Die Akkus sind leer oder defekt. - Stellen Sie das Mobilteil richtig auf die Basisstation. Reinigen Sie die Kontaktflächen am Mobilteil und an der Basisstation mit einem weichen trockenen Tuch. - Stellen Sie das Mobilteil für 15 Stunden in die Basisstation.
Die Rufnummernanzeige (CLIP ¹) funktioniert nicht	<ul style="list-style-type: none"> - Die Rufnummernanzeige ist ein Zusatzdienst Ihres Netzbetreibers. Bitte fragen Sie Ihren Netzbetreiber nach weiteren Informationen. - Der Anrufer hat das Übertragen seiner Rufnummer unterdrückt.

14 Technische Eigenschaften

Technische Daten

Merkmal	Wert
Standard	DECT ² -GAP ³
Stromversorgung (Basisstation)	Eingang: 100-240 V, 50/60 Hz Ausgang: 7,5 V, 300 mA
Stromversorgung (Ladestation)	Eingang: 100-240 V, 50/60 Hz Ausgang: 7,5 V, 200 mA
Reichweite	Außen: ca. 300 m Innen: ca. 50 m
Bereitschaftsmodus	Bis zu 100 h
Max. Gesprächsdauer	Bis zu 10 h
Aufladbare Akkus	NiMH 3,6 V 400 mAh

¹ **CLIP:** Calling Line Identification Presentation = Anzeige der Rufnummer eines Anrufers.

² **DECT:** Digital Enhanced Cordless Telecommunication = Standard für kabellose Telefone.

³ **GAP:** Generic Access Profile = Standard für das Zusammenwirken von Mobilteilen und Basisstationen unterschiedlicher Hersteller.

Merkmal	Wert
Wahlverfahren	Ton-Wahlverfahren Impuls-Wahlverfahren
Zulässige Umgebungstemperatur	Normal: 15 °C bis 35 °C Extrem: 0 °C bis 40 °C
Zulässige relative Luftfeuchtigkeit	0 % bis 90 %
Flashzeiten	100 ms, 300 ms

Werkseinstellungen

Mobilteil

Wecker	Aus
Ruftonlautstärke	Lautst. 5
Klingelton Externer Anruf / Klingelton Interner Anruf	Melodie 1 / Melodie 2
Hörerlautstärke	Lautst. 4
Tastenton	Ein
Bildschirmschoner	Aus
Sprache	Deutsch
Mobilteil-Name	DF 1001
Auto-Talk	Ein
Zeitformat	24-Stunden

Basisstation

Die Werkseinstellungen werden über das Menü wiederhergestellt. Auf Seite 13 finden Sie die Position im Menü.

Wählmodus	Tonwahl
Flash-Zeit (Rückruf-Modus)	100 ms (R-Taste 1)
System-PIN	0000

Pflegehinweise / Garantie

Konformitätserklärung

Dieses Gerät erfüllt die Anforderungen der EU-Richtlinie:

1999/5/EG Richtlinie über Funkanlagen und Telekommunikations-einrichtungen und die gegenseitige Anerkennung ihrer Konformität. Die Konformität mit der o. a. Richtlinie wird durch das CE-Zeichen auf dem Gerät bestätigt. Für die komplette Konformitätserklärung nutzen Sie bitte den kostenlosen Download von unserer Website www.switel.com.



15 Pflegehinweise / Garantie

Pflegehinweise

- Reinigen Sie die Gehäuseoberflächen mit einem weichen und fussel-freien Tuch.
- Verwenden Sie keine Reinigungs- oder Lösungsmittel.

Garantie

SWITEL - Geräte werden nach den modernsten Produktionsverfahren hergestellt und geprüft. Ausgesuchte Materialien und hoch entwickelte Technologien sorgen für einwandfreie Funktion und lange Lebensdauer. Ein Garantiefall liegt nicht vor, wenn die Ursache einer Fehlfunktion des Geräts bei dem Telefonnetzbetreiber oder einer eventuell zwischengeschalteten Nebenstellenanlage liegt. Die Garantie gilt nicht für die in den Produkten verwendeten Batterien, Akkus oder Akkupacks. Die Garantiezeit beträgt 24 Monate, gerechnet vom Tage des Kaufs.

Innerhalb der Garantiezeit werden alle Mängel, die auf Material- oder Herstellungsfehler zurückzuführen sind, kostenlos beseitigt. Der Garantieanspruch erlischt bei Eingriffen durch den Käufer oder durch Dritte. Schäden, die durch unsachgemäße Behandlung oder Bedienung, natürliche Abnutzung, durch falsches Aufstellen oder Aufbewahren, durch unsachgemäßen Anschluss oder Installation sowie durch höhere Gewalt oder sonstige äußere Einflüsse entstehen, fallen nicht unter die Garantieleistung. Wir behalten uns vor, bei Reklamationen die defekten Teile auszubessern, zu ersetzen oder das Gerät auszu-tauschen. Ausgetauschte Teile oder ausgetauschte Geräte gehen in unser Eigentum über. Schadenersatzansprüche sind ausgeschlossen, soweit sie nicht auf Vorsatz oder grober Fahrlässigkeit des Herstellers beruhen.

Sollte Ihr Gerät dennoch einen Defekt innerhalb der Garantiezeit aufweisen, wenden Sie sich bitte unter Vorlage Ihrer Kaufquittung ausschließlich an das Geschäft, in dem Sie Ihr SWITEL - Gerät gekauft haben. Alle Gewährleistungsansprüche nach diesen Bestimmungen sind ausschließlich gegenüber Ihrem Fachhändler geltend zu machen. Nach Ablauf von zwei Jahren nach Kauf und Übergabe unserer Produkte können Gewährleistungsrechte nicht mehr geltend gemacht werden.

1 Consignes de sécurité

Lisez très attentivement ce mode d'emploi.

Utilisation conforme à son usage

Ce téléphone convient pour téléphoner à l'intérieur d'un réseau téléphonique. Toute autre utilisation est considérée comme non conforme à son usage. Des modifications ou changements effectués d'un propre gré ne sont pas autorisés. N'ouvrez en aucun cas l'appareil et n'effectuez aucun essai de réparation vous-même.

Lieu d'installation

Évitez les nuisances causées par la fumée, la poussière, les vibrations, les produits chimiques, l'humidité, la grande chaleur ou un ensoleillement direct.

Ne vous servez pas du combiné dans des endroits exposés aux explosions.

Bloc secteur



Attention : N'utilisez que le bloc secteur fourni avec l'appareil, d'autres pouvant endommager votre téléphone. Vous ne devez pas bloquer l'accès au bloc secteur par des meubles ou d'autres objets.

Piles rechargeables



Attention : Ne jetez jamais les piles rechargeables dans le feu. N'utilisez que des piles rechargeables du même type ! Observez une polarisation correcte ! Il y a risque d'explosion lors de leur chargement si la polarisation est incorrecte.

Panne de courant

En cas de panne de courant, il n'est pas possible de téléphoner avec cet appareil. Pour les cas d'urgence, ayez à votre disposition un téléphone à fil fonctionnant sans alimentation externe en courant.

Appareils médicaux



Attention : N'utilisez pas ce téléphone à proximité d'appareils médicaux. Son influence ne peut pas être entièrement exclue.

Les téléphones **DECT**¹ peuvent causer un bourdonnement désagréable dans les appareils auditifs.

Compatible avec les appareils auditifs

Ce téléphone est compatible avec la plupart des prothèses auditives en vente sur le marché. Cependant, un fonctionnement irréprochable ne peut être garanti pour chacune d'entre elles.

¹ **DECT:** Digital Enhanced Cordless Telecommunication = Standard pour les téléphones sans fil.

Élimination

Si vous voulez vous séparer de votre appareil, veuillez l'apporter au centre de collecte de l'organisme d'élimination des déchets de votre commune (par ex. centre de recyclage). L'icône ci-contre signifie que vous ne devez en aucun cas jeter votre appareil dans les ordures ménagères ! D'après la loi relative aux appareils électriques et électroniques, les propriétaires d'appareils usagés sont tenus de mettre tous les **appareils électriques et électroniques** usagés dans un collecteur séparé.



Éliminez les piles rechargeables auprès d'un revendeur spécialisé ainsi que dans des centres de collecte qui tiennent à votre disposition les collecteurs appropriés correspondants.



Éliminez les **fournitures d'emballage** conformément au règlement local.

2 Mettre le téléphone en service

Remarques concernant la sécurité



Attention : Avant de mettre votre appareil en service, lisez impérativement les consignes de sécurité mentionnées au chapitre 1.

Vérifier le contenu de l'emballage

Les éléments suivants font partie de la livraison :

Contenu	Modèle DF 100x			
	DF 1001	DF 1002 ¹	DF 1003 ¹	DF 1004 ¹
Base avec bloc secteur	1	1	1	1
Chargeur avec bloc secteur	-	1	2	3
Combiné	1	2	3	4
Câble de raccordement téléphonique	1	1	1	1
Piles rechargeables	2	4	6	8
Mode d'emploi	1	1	1	1

¹ Le site www.switel.com vous indiquera si cet ensemble téléphonique est déjà disponible.

Mettre le téléphone en service

Raccorder la base



Attention : Posez la base à une distance minimum d'1 m par rapport à d'autres appareils électroniques, une distance inférieure pouvant provoquer des interactions.

Raccordez la base comme représenté sur le croquis. Pour des raisons de sécurité, n'utilisez que le bloc secteur fourni avec l'appareil ainsi que le câble de raccordement téléphonique ci-joint.

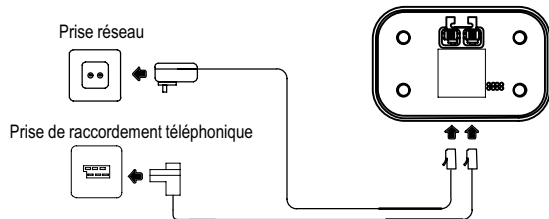

Attention : N'utilisez pour la base que le bloc secteur ayant la fiche transparente et les valeurs (sortie 7,5 V, 300 mA).

Raccorder le chargeur²

Raccordez le chargeur tel que représenté sur le croquis. Pour des raisons de sécurité, n'utilisez que le bloc secteur fourni avec l'appareil.

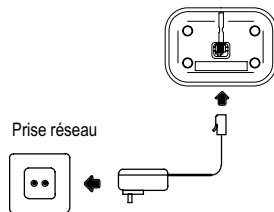

La station de base de votre téléphone est équipée d'une alimentation à découpage SW-075030EU à haut rendement énergétique (entrée 100~240 V_{AC}, sortie 7,5 V_{DC}, 300 mA). Sans charge, le courant entrant s'élève à env. 0,2 W. Le rendement moyen est d'env. 67 %.

Puissance absorbée de la station de base :

- en mode de fonctionnement (disponible/conversation) : env. 1,4 W
- pendant le chargement du combiné : env. 2,2 W

La(Les) station(s) de chargement livrée(s) avec un set de téléphone est (sont) équipée(s) d'une alimentation à découpage SW-075020EU à haut rendement énergétique (entrée 100~240 V_{AC}, sortie 7,5 V_{DC}, 200 mA). Sans charge, le courant entrant s'élève à 0,2 W. Le rendement moyen est d'env. 66 %.

- sans le combiné : env. 0,2 W
- pendant le chargement du combiné : env. 1,1 W

Mettre en place les piles rechargeables

Ouvrez le compartiment à piles. Insérez les piles rechargeables dans le compartiment à piles ouvert. N'utilisez que des piles de type AAA NiMH 1,2 V. Observez une polarisation correcte ! Fermez le compartiment à piles rechargeables.

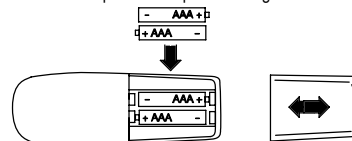

Recharger les piles rechargeables



Lors de la première mise en service, laissez le combiné pendant **au moins 15 heures** sur la base / le chargeur.

Si vous avez correctement posé le combiné sur la base / le chargeur, un signal indicateur se fait entendre et le voyant de contrôle de charge s'allume. Le combiné chauffe lors du chargement. C'est normal et inoffensif. Ne chargez pas le combiné avec des chargeurs d'autres fabricants. Le **niveau actuel de chargement des piles rechargeables** est affiché à l'écran :



Plein



À moitié vide



Vide

² Valable uniquement pour les installations téléphoniques équipées d'au moins deux combinés ☞ "Contenu de l'emballage" à la page 21.

Régler la langue de l'écran

Sélectionnez la langue correspondante (voir "structure de menu" page 29) :

Menü > Mobilteil-Einst. > Sprache >...

Menu > Réglages combiné > Langue >...

Régler la date et l'heure du combiné

Vous réglez la date et l'heure via le menu. La page 31 vous donnera la position dans le menu.

Prise d'appel automatique (Auto-Talk)

Si vous avez activé cette fonction, l'appel sera automatiquement pris lorsqu'il y aura un appel en attente sur le combiné de la base. La prise d'appel automatique s'active ou se désactive via le menu. La page 32 vous donnera la position dans le menu.



Installations PABX

La page 28 vous donnera de plus amples informations au cas où vous désiriez raccorder votre téléphone à une installation PABX.

Réduction du rayonnement (mode ÉCO)

Le rayonnement est, comparé aux téléphones sans fil DECT standard, considérablement réduit en mode veille (si le combiné repose sur la base).

En mode de communication, le rayonnement est réduit en fonction de l'éloignement du combiné par rapport à la base.

 Réglage usine = Réglages → Réglages base → Mode ÉCO → Désactivé









Vous pouvez régler le téléphone de sorte que le rayonnement soit réduit  page 32.

 En cas de besoin, vous pouvez augmenter la portée du système téléphonique en désactivant le mode ECO.

3 Éléments de manipulation

Dans ce mode d'emploi, les touches de votre téléphone seront représentées par la suite par des icônes encadrées standardisées. Il peut donc y avoir de légères différences entre les icônes des touches de votre téléphone et celles des touches utilisées ici.

Combiné

- 1 Écouteur
- 2 Écran
- 3 Touche softkey droite
- 4  Navigation vers le haut / Répétition des derniers numéros
- 5  Touche pour raccrocher
- 6  Touche / Verrouillage des touches
- 7  Téléphoner en interne
- 8 Microphone
- 9  Touche
- 10  Touche / Numérotation temporaire par tonalité
- 11  Touche de communication / Mode mains-libres
- 12  Navigation vers le bas / Répertoire
- 13 Touche softkey gauche
- 14 Haut-parleur (sur la face arrière)

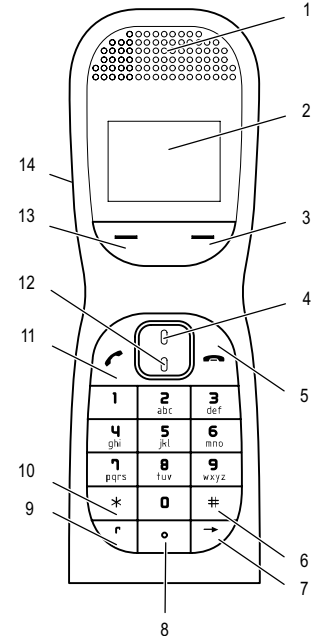

Introduction

Base

- 1 DEL : Affichage du niveau de charge
- 2 Chercher le combiné (paging)
- 3 Contacts de chargement

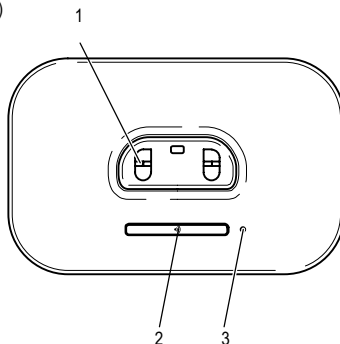

Chargeur¹

- 1 Contacts de chargement
- 2 DEL : Affichage du niveau de charge

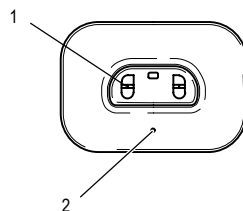

4 Introduction











Vous trouverez dans ce chapitre des informations de base vous expliquant comment vous servir du mode d'emploi et du téléphone.

Mode de représentation dans le mode d'emploi

Visualisation	Description
	Visualisation des touches
	Appuyer brièvement sur la touche représentée
3 sec.	Appuyer 3 secondes sur la touche représentée
	Maintenir appuyée la touche représentée
Relâcher	Relâcher la touche représentée
	Saisir des chiffres ou des lettres
	Le combiné sonne
	La base sonne
	Prendre le combiné de la base
	Poser le combiné sur la base
	Visualisation des textes de l'écran
	Visualisation des icônes de l'écran
	Appuyer sur la touche softkey page 25

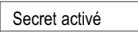
¹ Valable uniquement pour les kits téléphoniques équipés d'au moins deux combinés
 "Contenu de l'emballage" à la page 21.

Icônes et textes à l'écran du combiné

Icône	Description
	Affichage de la capacité des piles rechargeables
	Fonction d'alarme activée
	Volume sonore de la sonnerie = désactivée
	De nouveaux appels se trouvent dans la liste d'appels ☞ page 34.
	Le mode mains-libres est activé ☞ page 27.
	Le verrouillage du clavier est activé ☞ page 28.
	Répondeur dans le réseau téléphonique. Service confort VMWI¹ de votre opérateur ☞ page 28.
	Le microphone est réglé sur silencieux ☞ page 27.
	Constant : la liaison avec la base est bonne. Clignotant : la liaison avec la base s'interrompt. Rapprochez-vous de celle-ci.
	Votre répondeur est branché.
	De nouveaux messages se trouvent sur le répondeur.

¹ VMWI: Visual Message Waiting Indication = Affichage optique de nouveaux messages.

Mode veille

Toutes les descriptions contenues dans ce mode d'emploi partent du principe que le combiné se trouve en mode veille. Vous parviendrez au mode veille en appuyant sur la touche .

Mode économie d'énergie

Au bout d'un certain temps en mode veille, le combiné passe en mode économie d'énergie. Touches et écran ne sont plus éclairés. Appuyez sur la touche  pour accéder au mode veille.

Touches de navigation

Les touches softkey (1) et (6) sont occupées par des fonctions différentes dans les divers menus. Dans ce mode d'emploi, elles sont toujours dénommées selon les textes inscrits ci-dessus à l'écran.

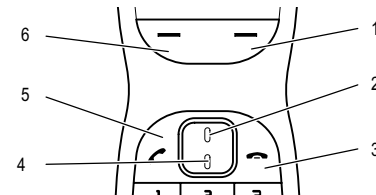











Touche	En mode veille	Dans le menu
1	- Ouvrir le Menu répertoire	- Navigation Retour
2	- Ouvrir la liste de répétition automatique des derniers numéros	- Navigation vers le haut
3	- Allumer et éteindre le combiné	- Passer au mode veille / Annuler les actions
4	- Ouvrir le répertoire	- Navigation vers le bas
5	- Touche de communication / Mode mains-libres	
6	- Ouvrir le menu principal	- Navigation Continuer

Téléphoner

Navigation dans le menu

Vous pouvez accéder à toutes les fonctions via différents menus.

La structure de menu vous montre comment accéder à la fonction désirée  page 29.







	Ouvrir le menu principal
 SMS	Sélectionner le sous-menu désiré
	Ouvrir le sous-menu
 Rédiger SMS	Sélectionner la fonction désirée
	Ouvrir la fonction
	Saisir des chiffres ou des lettres via le pavé numérique
	Confirmer les entrées
	Reculer d'une position
	Interrompre les opérations de programmation et de sauvegarde et retourner en mode veille



Chaque opération est automatiquement interrompue si vous n'effectuez pas de saisie dans les 30 secondes.

Créer des enregistrements du répertoire - exemple

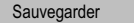
L'exemple **Créer des enregistrements du répertoire** vous explique ici comment naviguer dans les menus et réaliser des paramètres. Pour tous les réglages, procédez comme dans cet exemple.

	Ouvrir le répertoire
 Ajouter un nom	Sélectionner le sous-menu et confirmer
Entrez nom : 	Saisir le nom (max. 12 caractères) et confirmer
OK	
Entrez numéro : 	Saisir le numéro d'appel (max. 24 chiffres) et confirmer
	
	Sélectionner la mélodie d'appel et confirmer
	

5 Téléphoner

Prendre un appel



Prendre la communication

Terminer la communication



Terminer la communication

Appeler



Saisir le numéro d'appel (max. 24 chiffres)

Effacer

Si la saisie est erronée, effacer le dernier chiffre



Composer le numéro



Vous pouvez également appuyer d'abord sur la touche de communication, vous obtenez ainsi la tonalité. Les chiffres saisis de votre numéro d'appel seront immédiatement composés. Une correction individuelle des chiffres du numéro n'est pas possible quand la communication est établie de cette manière.

Répétition des derniers numéros

Votre téléphone enregistre les 20 derniers numéros composés dans une liste de répétition automatique des derniers numéros.



Ouvrir la liste de répétition des derniers numéros



Sélectionner l'enregistrement et établir la communication

Rappeler des numéros d'appel entrés

Votre téléphone enregistre 30 appels dans une liste d'appels.



Ouvrir le menu de la liste des appels

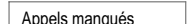

Sélect.

Ouvrir la liste d'appels



Sélectionner l'enregistrement et établir la communication

Composer des numéros d'appel à partir du répertoire

Vous devez avoir enregistré des numéros dans le répertoire  page 26 et 34.



Ouvrir le répertoire



Sélectionner l'enregistrement et établir la communication

Téléphoner en interne¹

Téléphoner en interne

Vous devez avoir déclaré deux ou plusieurs combinés (CB1, CB2, ...) sur votre base afin de pouvoir téléphoner gratuitement en interne.

MT1 : **INT**, par ex. **2 sec**, **OK**
Composer le numéro interne du combiné désiré

MT2 :
Prendre une communication interne sur un autre combiné

MT1 / MT2 :
Terminer une communication interne

Transférer des communications externes en interne

MT1 : **INT**, par ex. **2 sec**, **OK**
Composer un numéro interne pendant la communication externe.

MT2 :
Prendre une communication interne sur un autre combiné

MT1 :
Transférer une communication



Si le combiné appelé devait ne pas répondre, vous pouvez reprendre la communication externe en appuyant sur la touche **INT**.

Intercommunication / Va-et-vient

Vous pouvez, pendant une communication externe, composer le numéro d'un autre combiné, pour intercommuniquer. Le correspondant externe est maintenu en ligne pendant que vous parlez avec le correspondant interne. Vous pouvez répéter cette opération autant de fois que vous le désirez.

MT1 : **INT**, par ex. **2 sec**, **OK**
Composer un numéro interne pendant la communication externe.

MT2 :
Prendre une communication interne sur un autre combiné

CB1 : **INT**
Changer de correspondant

Mener des conférences téléphoniques

Une communication externe peut être branchée sur un autre correspondant interne dans le but de mener une conférence.

MT1 : **INT**, par ex. **2 sec**, **OK**
Composer un numéro interne pendant la communication externe.

MT2 :
Prendre une communication interne sur un autre combiné

MT1 **Joindre**
Commencer la conférence

MT1 / MT2 :
Terminer la conférence

Régler le volume sonore de l'écouteur

Vous pouvez régler le volume sonore sur 8 sensibilités pendant une communication.

/
Sélectionner le volume de votre choix

Mode mains-libres

Utilisez cette fonction pour entendre le correspondant par l'intermédiaire du haut-parleur.

Activer le mode mains-libres

Désactiver le mode mains-libres

Affichage de la durée de la communication

Pendant une communication, sa durée s'affiche en minutes et secondes.

Mettre le microphone du combiné sur silencieux

Pendant une communication, vous pouvez activer et désactiver le microphone du combiné.

Secret
Désactiver le microphone (le mettre sur silencieux)

Désactivé
Activer le microphone

¹ Téléphoner en interne n'est possible qu'avec au moins deux combinés ☞ "Contrôler le contenu de l'emballage" à la page 21.

Installations PABX / Services confort

Verrouillage des touches

Le verrouillage des touches doit empêcher que des fonctions soient déclenchées par inadvertance.

3 sec.  # Activer le verrouillage du clavier

Déverr.  # Désactiver le verrouillage du clavier

 Lorsque le verrouillage du clavier est activé, vous pouvez comme d'habitude réceptionner des appels entrants.

Chercher le combiné (paging)

Si vous avez égaré votre combiné, vous pouvez le retrouver facilement grâce à un son de recherche.

  Lancer le son de recherche

 ou  Arrêter le son de recherche

Allumer et éteindre le combiné

Vous pouvez éteindre le combiné pour épargner les piles rechargeables.

3 sec.  Éteindre le combiné

3 sec.  Allumer le combiné

6 Installations PABX / Services confort

Fonction R sur les installations à postes supplémentaires

Si votre téléphone est raccordé à une installation à postes supplémentaires, vous pouvez, au moyen de la touche **R**, utiliser certaines fonctions, comme par ex. le transfert d'appels et le rappel automatique. Veuillez lire dans le mode d'emploi de votre installation PABX le temps de flash à paramétrer pour l'utilisation de ces fonctions. Le revendeur auprès duquel vous avez acheté l'installation vous dira si votre téléphone fonctionne parfaitement sur votre installation PABX. Le temps de flash se paramètre via le menu. À la page 32 vous trouverez la position (Mode de rappel) dans le menu.

Fonction R et services confort

Votre téléphone supporte des services confort de votre opérateur tels que le va-et-vient, la signalisation d'appel en instance et la conférence. Vous pouvez les utiliser via la touche **R**. Demandez à votre opérateur le temps de flash à paramétrer pour utiliser ces services conforats. Contactez-le pour déconnecter ces services. Le temps de flash se paramètre via le menu. À la page 32 vous trouverez la position (Mode de rappel) dans le menu.

Affichage du numéro d'appel (CLIP¹)



L'affichage du numéro d'appel est un service confort de votre opérateur. Veuillez lui demander de plus amples informations.

Si cette fonction est disponible sur votre ligne téléphonique, le numéro d'appel du correspondant vous sera affiché dès que le téléphone sonnera. Si votre correspondant a bloqué la transmission de son numéro, un message correspondant sera affiché. Le numéro d'appel ne peut pas être affiché et ne peut donc pas être sauvegardé dans la liste d'appels.

Pause de numérotation

Dans le cas d'installations PABX, il est nécessaire de composer auparavant un code réseau pour obtenir la tonalité. Sur quelques installations PABX plus anciennes, vous devez attendre quelques instants avant de pouvoir entendre la tonalité. Pour ces installations PABX, une pause de numérotation peut être insérée après le code réseau afin de pouvoir continuer à numéroter directement sans attendre la tonalité.

3 sec.  Insérer une pause de numérotation

Après le code réseau, le numéro est composé au bout d'un temps déterminé.



La pause peut également être enregistrée lors de la saisie de numéros d'appel dans le répertoire.

Répondeur dans le réseau téléphonique

Le répondeur dans le réseau téléphonique est un service confort offert par de nombreux opérateurs. Si votre opérateur met à votre disposition un répondeur dans le réseau téléphonique, vous serez informé par une icône de l'arrivée de nouveaux messages (VMWI²). Vous ne pouvez disposer de cette fonction que si votre opérateur offre ce service. Veuillez lui demander de plus amples informations.



¹ CLIP: Calling Line Identification Presentation = Affichage du numéro d'appel d'un correspondant.

² VMWI: Visual Message Waiting Indication = Affichage optique de nouveaux messages.

7 Structure du menu

Menu principal

Vous parvenez au menu principal en appuyant sur la touche softkey **Menu** . Vous trouverez comment vous déplacer dans le menu et effectuer des saisies à la page 25.

SMS	Rédiger SMS		Options	Envoyer	Entrez numéro : 	Envoyer
				Sauvegarder		
				Insérer symbole		
				Insérer icône		
				Insérer modèle		
	Boite réception	Lire	Options	Répondre		
				Faire suivre		
				Détails SMS		
				Utiliser numéro		
				Supprimer		
	Brouillons	Modifier	Options	voir Rédiger SMS		
	Boite d'envoi	Lire	Options	Faire suivre		
				Supprimer	Oui/Non	
	Modèles	Options	Modifier			
				Supprimer	Oui/Non	
	Supprimer mess.	Boite réception		Oui/Non		
		Brouillons		Oui/Non		
		Boite d'envoi		Oui/Non		
		Tous les SMS		Oui/Non		
Réglages SMS	Centres SMS		Numéro émission	Centre 1		

Structure du menu

		Centre 2		
	Centre réception	Centre 1 - 2	Entrez numéro : ☎	Sauvegarder
	Centre émission	Centre 1 - 2	Entrez numéro : ☎	Sauvegarder
Numéro boîte SMS	☎	Sauvegarder		
Taille SMS	160 caractères			
	612 caractères			
Alerte SMS	Activé / Désactivé			
Utilisateurs	Utilisateur 1 - 4	Options	Modifier	Entrez nom : ☎

Journal	Appels manqués	Options	Voir les détails	
			Sauvegarder num.	Entrez nom : ☎ Entrez numéro : ☎
			Envoyer SMS	☎
			Supprimer appel	
	Appels reçus	Options	Voir Appels manqués	
	Appels émis	Options	Voir Appels manqués	
	Supprimer appels	Appels manqués, Appels reçus, Appels émis		Oui/Non







Agenda	Options	Ajout évènement ☎	Entrez la date : ☎	Entrez l'heure : ☎	Silencieux
					Réveil Une fois / Annuel
		Voir les détails			
		Modif. évènement ☎	Entrez la date : ☎	Entrez l'heure : ☎	Silencieux
					Réveil Une fois / Annuel
	Envoyer par SMS	Options	Envoyer	Entrez numéro : ☎	Envoyer

		Sauvegarder
		Insérer symbole
		Insérer icône
		Insérer modèle
Suppr. évènement	Supprimer évènement ?	Oui/Non
Tout supprimer	Supprimer ts les évènements ?	Oui/Non

Horloge & réveil	Date & heure	Entrez la date : 📅	Entrez l'heure : 🕒
	Réveil	Désactivé/Activé	
	Format heure	12 heures	
		24 heures	

Réglages	Réglages combiné	Mélodie	Appel externe	Mélodie 1 - 20
			Appel interne	Mélodie 1 - 20
		Volume sonnerie	Silence	
			Volume 1 - 5	
		Volume écouteur	Volume 1 - 8	
		Nom du combiné	📅	
		Langue	English (UK)	
			Français	
			Deutsch	
			Italiano	
			Español	

Structure du menu

Réglages base	Économis. écran	Horloge / Désactivé		
	Durée éclairage	15 secondes		
		30 secondes		
		45 secondes		
	Décrochage auto	Désactivé/Activé		
	Bip touches	Désactivé/Activé		
	Code accès PABX	Désactivé/Activé		
		Définir code		
	Mélodie	Mélodie 1 - 5		
		Mélodie par défaut		
Réglages base	Volume sonnerie	Silence		
		Volume		
	Mode numérot.	Décimale		
		Fréq. vocales		
	Mode de rappel	Rappel 1		
		Rappel 2		
	1ère sonnerie	Activé/ Désactivé		
	Code PIN	Ancien PIN : 	Nouveau PIN : 	Confirmez PIN : 
	Réinitialisation	Êtes-vous sûr ?	Oui/Non	Entrez code PIN : 
	Mode ÉCO	Désactivé/Activé		
Souscription	Souscrire comb.	Base 1 - 4	Entrez code PIN : 	
	Sélection base	Base 1 - 4	Entrez code PIN : 	
	Désouscrire			

Noms	Options	Voir les détails	
	Envoyer SMS	Options	Envoyer
		Entrez numéro : ☎	Envoyer
		Sauvegarder	
		Insérer symbole	
		Insérer icône	
		Insérer modèle	
	Modifier un nom	Entrez nom : ☎	Entrez numéro : ☎
			Mélodie 1 - 20
			Mélodie par défaut
	Copier un nom	Vers Comb ou Base	
	Mélodie	Mélodie 1 - 20	
		Mélodie par défaut	
	Supprimer nom	Oui/Non	
	Appel rapide	Touche 1 - 3	Attribuer
			Effacer entrée
Ajouter un nom	Entrez nom : ☎	Entrez numéro : ☎	Mélodie 1 - 20
			Mélodie par défaut
Copier répertoire	Vers Comb ou Base		
État mémoire			
Suppr. répertoire	Supprimer tous les noms ?		Oui/Non

Répertoire

8 Répertoire

Vous pouvez enregistrer 250 numéros d'appel et le nom y afférant dans votre répertoire.

- Les enregistrements du répertoire sont rangés par ordre alphabétique. Pour accéder directement à l'enregistrement désiré, appuyez sur l'initiale correspondante.

Saisir le nom

Des lettres sont gravées sur les touches numériques. En appuyant plusieurs fois sur la touche adéquate, vous pouvez saisir des lettres, des chiffres et des symboles.

Entrer des espaces

Supprimer

ou Saisir des caractères spéciaux



Pour saisir deux fois la même lettre, appuyez sur la touche correspondante. Attendez que le curseur soit passé derrière la lettre. Puis tapez la lettre une nouvelle fois.

Créer des enregistrements du répertoire

Voir l'exemple page 26.

Modifier des enregistrements du répertoire

Ouvrir le menu principal

/ , Sélectionner le répertoire

et confirmer

/ Sélectionner un enregistrement du répertoire et confirmer

/ , Sélectionner le sous-menu et confirmer

Entrez nom : , Modifier le nom et confirmer

Entrez numéro : , Modifier le numéro d'appel et

confirmer

Sélectionner la mélodie d'appel et

sauvegarder

¹ CLIP: Calling Line Identification Presentation = Affichage du numéro d'appel d'un correspondant.

Effacer des enregistrements du répertoire

Effacer un enregistrement

Ouvrir le menu principal

/ , Sélectionner le répertoire

et confirmer

/ Sélectionner un enregistrement du répertoire et confirmer

/ , Sélectionner le sous-menu et confirmer

, / Confirmer ou annuler l'effacement

Effacer tous les enregistrements

Ouvrir le menu principal

/ , Sélectionner le sous-menu et

confirmer

, Effacement

/ confirmer ou annuler

9 Liste d'appels

30 numéros d'appel en tout sont enregistrés dans la liste d'appels.



L'affichage du numéro d'appel (CLIP¹) est un service confort de votre opérateur. Votre téléphone affiche les numéros d'appel à l'écran si votre opérateur offre ce service. Veuillez lui demander de plus amples informations.

Faire afficher/Appeler les numéros issus de la liste d'appels

Ouvrir le menu principal

/ , Sélectionner le sous-menu et

confirmer

ou ,



Ouvrir la liste d'appels

 Composer le numéro

Enregistrer un numéro de la liste d'appel dans le répertoire

Vous pouvez sauvegarder un numéro d'appel dans le répertoire directement à partir de la liste d'appels.



Menu Ouvrir le menu principal

 /  Journal , Sélectionner le sous-menu et



Sélect. confirmer

Appels manqués ou Appels reçus ,

Sélect. Ouvrir la liste d'appels

 /  Options Sélectionner l'enregistrement et confirmer

Sauvegarder num. , **Sélect.** Ouvrir la fonction

Entrez nom :   OK Saisir le nom (max. 12 positions) et confirmer

Entrez numéro :  Adapter le numéro d'appel



Sauvegarder et confirmer

Mélodie 1 - 20

Sélect. Sélectionner la mélodie d'appel et sauvegarder

Effacer des numéros individuels



Menu Ouvrir le menu principal

 /  Journal , Sélectionner le sous-menu et

Sélect. confirmer

Appels manqués ou Appels reçus ,



Sélect. Ouvrir la liste d'appels

 /  Options Sélectionner l'enregistrement et confirmer



Supprimer appel , **Sélect.** Confirmer la fonction

Effacer tous les numéros d'appel

Menu Ouvrir le menu principal

 /  Journal , Sélectionner le sous-menu et

Sélect. confirmer

 /  Supprimer appels Ouvrir le sous-menu

Appels manqués ou Appels reçus ou

Appels émis ou Tous les appels ,

Sélect. Sélectionner la liste d'appels

Supprimer tous les appels ? , Effacement

Oui / Non Confirmer ou annuler

10 Fonctions particulières

Système de numérotation

Vous pouvez utiliser votre téléphone tant avec les centrales téléphoniques analogiques (numérotation par impulsions) qu'avec les nouvelles centrales téléphoniques numériques (numérotation par tonalité). Le système de numérotation est programmé via le menu. La page 32 vous donnera la position dans le menu.

Numérotation temporaire par tonalité

Si vous ne pouvez utiliser votre téléphone qu'avec la numérotation par impulsions, vous n'avez pas besoin de renoncer aux avantages de la numérotation par tonalité (par ex. : consultation d'un répondeur dans le réseau téléphonique). Vous pouvez passer provisoirement à la numérotation par tonalité pendant que vous passez une communication.

2 sec.  Appuyer sur la touche pendant la communication

Quand la communication est terminée, la numérotation par impulsions est automatiquement rétablie.

Alarme

Cette fonction vous permet de vous faire réveiller par votre combiné à un moment précis. La page 31 vous donnera la position dans le menu.

Agenda

Vous avez la possibilité de sauvegarder jusqu'à 5 enregistrements dans votre téléphone (par ex. anniversaires) qui vous seront rappelés le jour correspondant. Ces enregistrements peuvent contenir jusqu'à caractères.

Créer des enregistrements dans l'agenda

Menu	Ouvrir le menu principal
<input type="button" value="v"/> / <input type="button" value="^"/> <input type="text" value="Agenda"/>	Sélectionner Agenda
Sélect.	et confirmer
Options	<input type="text" value="Ajout évènement"/>
Sélect.	et confirmer
Sauvegarder	Entrer l'objet et confirmer
Sauvegarder	Entrer la date et confirmer
Sauvegarder	Entrer l'heure et confirmer
<input type="button" value="v"/> / <input type="button" value="^"/> <input type="text" value="Silencieux"/> ou	
<input type="text" value="Réveil"/> <input type="button" value="Sélect."/>	Sélectionner le type de rappel et confirmer
Si vous avez sélectionné <input type="text" value="Réveil"/> :	
<input type="button" value="v"/> / <input type="button" value="^"/> <input type="text" value="Une fois"/> ou	
<input type="text" value="Annuel"/> <input type="button" value="Sélect."/>	Sélectionner l'intervalle et confirmer
<input type="button" value="v"/> / <input type="button" value="^"/> <input type="text" value="A l'heure"/> ou	
<input type="text" value="30 minutes avant"/> <input type="button" value="Sélect."/>	Sélectionner le moment du rappel et confirmer

Vous trouverez des étapes de manipulation supplémentaires à la structure de menu page 30.

¹ CLIP: Calling Line Identification Presentation = Affichage du numéro d'appel d'un correspondant.

² SMS: Short Message Service = Service pour l'envoi de messages courts.

11 SMS

Conditions à remplir pour les SMS

Votre raccordement téléphonique doit disposer du service CLIP¹. Assurez-vous auprès de votre opérateur que ce service est bien connecté pour votre raccordement téléphonique. Pour tirer profit du service SMS², celui-ci doit être activé par votre opérateur.

- Des SMS ne peuvent pas être envoyés à partir de chaque installation à postes supplémentaires.



Si vous désirez envoyer des SMS à partir de votre installation à postes supplémentaires, sauvegardez dans votre combiné, avant le numéro de centre de service, le chiffre de la ligne principale de votre installation.

- Dans le cas des liaisons d'appel par appel, l'envoi de SMS n'est pas possible actuellement.
- L'envoi de messages SMS est payant.
- Si le récepteur n'utilise pas de service SMS sur son réseau fixe ou si son téléphone ne peut simplement pas recevoir de SMS, le SMS sera automatiquement livré sous forme de message vocal.
- Le calcul des frais est effectué par votre opérateur.

Centre de service SMS

La répartition de messages SMS se fait via un centre de service. Si vous désirez envoyer des messages écrits par SMS, vous devez programmer un numéro de centre de service dans votre combiné page 11. Veuillez demander à l'opérateur de votre choix le numéro de centre de service nécessaire et la manière de procéder pour activer le service SMS.



Votre téléphone est prêt à envoyer des messages écrits par SMS. Des numéros de centre SMS sont déjà programmés dans votre combiné. Activez le centre SMS de votre choix dans le menu SMS page 11.

Centre 1	Centre 2
Swisscom : 0622100000	Cablecom : 0435375370

Saisir du texte

Pour la saisie de texte, des lettres sont gravées sur les touches numériques. En appuyant plusieurs fois sur la touche adéquate, vous pouvez saisir des lettres, des chiffres et des symboles. Vous trouverez comment naviguer pour pouvoir écrire un SMS dans la structure de menu page 29.

	Passer des majuscules aux minuscules
Effacer	Effacer la dernière position

3 sec. Effacer

Effacer tout

Modèles de texte pour SMS

5 modèles de texte préprogrammés sont à votre disposition ☞ page 29.

Signal indicateur de SMS (alarme)

Quand vous avez reçu de nouveaux messages écrits, vous en êtes informés par un signal indicateur. Le signal s'active ou se désactive via le menu. La page 11 vous donnera la position dans le menu.

12 Extension du système téléphonique

Le standard international normé **GAP**¹ Règle la compatibilité entre les combinés et les bases de fabricants différents. Il est ainsi possible d'intégrer ensemble des appareils SWITEL et des appareils d'autres fabricants dans un système téléphonique. Il est toutefois possible que certaines fonctions ne soient pas disponibles.

Plusieurs combinés

Vous pouvez déclarer 5 combinés en tout sur votre base.

Déclaration de combinés

Avant de déclarer un combiné, vous devez mettre la base en mode de déclaration. Maintenez appuyée la touche de paging de la base jusqu'à ce qu'un signal sonore se fasse entendre. Maintenant, la base se trouve pendant 60 secondes en mode de déclaration. Continuez sur le combiné.

2 sec.  Démarrer le mode de déclaration

Déclarez maintenant le combiné ☞ page 33. Pour cela, utilisez le code PIN actuellement paramétré ☞ page 32.

Après la déclaration, un numéro d'appel interne est attribué au combiné.



Pour déclarer des combinés d'autres fabricants, veuillez lire leur mode d'emploi.

Annulation de combinés



Chaque combiné peut annuler d'autres combinés déclarés sur cette base.

Les combinés sont annulés via le menu. La page 33 vous donnera la position dans le menu.

¹ **GAP**: Generic Access Profile = Standard pour l'action conjointe de combinés et de bases de fabricants différents.

Extension du système téléphonique

Plusieurs bases

Vous pouvez élargir la portée de votre combiné si vous le déclarez simultanément à plusieurs bases. Il peut être déclaré simultanément sur 4 bases différentes. Chaque base a besoin d'une prise téléphonique individuelle. Ces raccordements peuvent porter le même numéro d'appel ou bien des numéros différents.



Les communications en cours ne peuvent pas être transférées d'une base à l'autre.

13 En cas de problèmes

Hotline de service

Si vous avez des problèmes avec votre téléphone, contrôlez d'abord les remarques suivantes. S'il s'agit de problèmes techniques, vous pouvez vous adresser à notre hotline de service en Suisse au numéro de tel. 0900 00 1675 (frais Swisscom à la date d'impression de ce manuel : CHF 2.60/min). Si vous jouissez de droits de garantie, adressez-vous à votre revendeur. La durée de la garantie est de 2 ans.

Questions et réponses

Questions	Réponses
Pas de connexion possible avec la base	- Contrôlez que vous vous êtes déclaré sur la base avec le code PIN correct ☞ page 32.
Pas de communication téléphonique possible	- Le téléphone n'est pas raccordé correctement ou est en dérangement. N'utilisez que le câble de raccordement téléphonique fourni avec l'appareil. - Testez avec un autre téléphone si votre raccordement téléphonique fonctionne. - Le bloc secteur n'est pas branché ou il y a une panne totale de courant. - Le pack de piles rechargeables est vide ou défectueux. - Vous vous êtes trop éloigné de la base. - Réglage erroné du système de numérotation ☞ page 32.

Caractéristiques techniques

La liaison est hâchée, s'interrompt	<ul style="list-style-type: none"> - Vous vous êtes trop éloigné de la base. - Mauvais lieu d'installation de la base.
Le système ne réagit plus	<ul style="list-style-type: none"> - Remettez toutes les fonctions via "Réinitialisation" en configuration usine  page 32. - Retirez le bloc secteur de la prise de courant pendant un court instant.
Le piles rechargeables se vide très rapidement	<ul style="list-style-type: none"> - Le piles rechargeables est vide ou défectueux. - Placez le combiné correctement sur la base. Nettoyez les surfaces de contact du combiné et de la base avec un chiffon doux et sec . - Posez le combiné sur la base pendant 15 heures.
L'affichage du numéro d'appel (CLIP ¹) ne fonctionne pas	<ul style="list-style-type: none"> - L'affichage du numéro d'appel est un service confort de votre opérateur. Veuillez lui demander de plus amples informations. - Le correspondant a bloqué la transmission de son numéro d'appel.

¹ **CLIP**: Calling Line Identification Presentation = Affichage du numéro d'appel d'un correspondant.

14 Caractéristiques techniques

Caractéristiques techniques

Caractéristique	Valeur
Standard	DECT ¹ -GAP ²
Alimentation en courant (base, fiche transparente)	Entrée : 100-240 V, 50/60 Hz Sortie : 7,5 V, 300 mA
Alimentation en courant (chargeur, fiche rouge)	Entrée : 100-240 V, 50/60 Hz Sortie : 7,5 V, 200 mA
Portée	À l'extérieur : env. 300 m À l'intérieur : env. 50 m
Mode veille	Jusqu'à 100 h
Durée max. de communication	Jusqu'à 10 h
Piles rechargeables	AAA NiMH 1,2 V
Système de numérotation	Numérotation par tonalité Numérotation par impulsions
Température ambiante autorisée	Normal: 15 °C à 35 °C Extrême : 0 °C à 40 °C
Humidité atmosphérique relative autorisée	0% à 90%
Temps de flash	100 ms, 300 ms

¹ **DECT**: Digital Enhanced Cordless Telecommunication = Standard pour les téléphones sans fil.

² **GAP**: Generic Access Profile = Standard pour l'action conjointe de combinés et de bases de fabricants différents.

Réglages usine

Combiné

Réveil	Désactivé
Volume sonnerie	Volume 5
Mélodie Appel externe / Mélodie Appel interne	Mélodie 1 / Mélodie 2
Volume écouteur	Volume 4
Bip touches	Activé
Économis. écran	Désactivé
Langue	Deutsch
Nom du combiné	DF 1001
Décrochage auto	Activé
Format heure	24 heures

Base

Les paramétrages usine sont rétablis via le menu.
La page 32 vous donnera la position dans le menu.

Mode numérot.	Fréq. vocales
Temps de flash (Mode de rappel)	100 ms (Rappel 1)
Code PIN	0000

Déclaration de conformité

Cet appareil répond aux exigences des directives de l'union européenne (UE) :

1999/5/CE : Directive sur les installations de radio et de télécommunication et la reconnaissance réciproque de leur conformité. La conformité à la directive ci-dessus est confirmée sur l'appareil par le symbole CE. Pour obtenir la déclaration de conformité intégrale, veuillez vous servir du téléchargement gratuit de notre site Internet www.switel.com.



15 Remarques d'entretien / Garantie

Remarques d'entretien

- Nettoyez les surfaces du boîtier avec un chiffon doux et non pelucheux.
- N'utilisez pas de produits d'entretien ou de solvants.

Garantie

Les appareils SWITEL sont fabriqués et contrôlés selon les procédés les plus modernes. Des matériaux sélectionnés et des technologies de pointe ont pour effet un fonctionnement irréprochable et une longue durée de vie. La garantie ne rentre pas en jeu si l'exploitant du réseau téléphonique ou une installation PABX éventuellement intercalée est responsable du dysfonctionnement de l'appareil. La garantie ne s'applique pas aux piles, piles rechargeables ou packs de piles rechargeables utilisés dans les produits. La durée de la garantie est de 24 mois à partir de la date d'achat.

Pendant la période de garantie, tous les défauts dus à des vices de matériel ou de fabrication seront éliminés gratuitement. Le droit à la garantie expire en cas d'intervention de l'acheteur ou de tiers. Les dommages provenant d'un manquement ou d'une manipulation incorrects, d'une usure naturelle, d'une mauvaise mise en place ou d'une mauvaise conservation, d'un raccordement ou d'une installation incorrects ainsi que d'un cas de force majeure ou autres influences extérieures sont exclus de la garantie. En cas de réclamations, nous nous réservons le droit de réparer, de remplacer les pièces défectueuses ou d'échanger l'appareil. Les composants remplacés ou les appareils échangés deviennent notre propriété. Les demandes de dommages et intérêts sont exclues tant qu'elles ne reposent pas sur l'intention ou une négligence grossière du fabricant.

Si votre appareil devait malgré tout présenter une défectuosité pendant la période de garantie, veuillez vous adresser, muni de la quittance d'achat, exclusivement au magasin où vous avez acheté votre appareil SWITEL. Vous ne pouvez faire valoir vos droits à la garantie selon ces dispositions qu'auprès de votre revendeur exclusivement. Deux ans après l'achat et la remise de nos produits, il n'est plus possible de faire valoir les droits à la garantie.

Indicazioni di sicurezza

1 Indicazioni di sicurezza

Leggere attentamente le presenti istruzioni per l'uso.

Impiego conforme agli usi previsti

Il presente telefono consente di svolgere telefonate all'interno di una rete telefonica. Qualsiasi altro impiego è considerato come non conforme agli usi previsti. Non sono consentite modifiche o trasformazioni non autorizzate. Non aprire per nessuna ragione l'apparecchio autonomamente, né compiere riparazioni di propria iniziativa.

Luogo di installazione

Evitare un'esposizione a fumo, polvere, vibrazioni, sostanze chimiche, umidità, calore e raggi solari diretti.

Non utilizzare l'unità portatile in aree esposte al rischio di deflagrazione.

Alimentatore di rete



Attenzione: Utilizzare solo l'alimentatore a spina fornito in dotazione visto che altri alimentatori di rete potrebbero addirittura danneggiare il telefono. Non ostacolare il libero accesso all'alimentatore a spina con mobili o altri oggetti simili.

Accumulatori ricaricabili



Attenzione: Non gettare gli accumulatori ricaricabili nel fuoco. Utilizzare solo accumulatori dello stesso tipo. Osservare la corretta polarità! Pericolo di esplosione durante il caricamento degli accumulatori in caso di errata polarità.

Caduta di tensione

In caso di caduta di tensione non è possibile compiere chiamate con questo telefono. Si consiglia di ricorrere in caso di emergenza ad un telefono con filo in grado di funzionare anche senza alimentazione elettrica esterna.

Apparecchiature mediche



Attenzione: Non utilizzare il telefono in prossimità di apparecchiature mediche. Non è infatti possibile escludere il rischio di possibili interferenze.

Telefoni DECT¹ possono causare un fastidioso ronzio in apparecchi acustici.

Compatibilità con apparecchi acustici

Il telefono è compatibile con il maggior numero di apparecchi acustici presenti sul mercato. Ciò nonostante non è possibile garantire un perfetto funzionamento con qualsiasi tipo di apparecchio acustico.

¹ DECT: Digital Enhanced Cordless Telecommunication = Standard per telefoni senza cavo.

Smaltimento

Procedere allo smaltimento dell'apparecchio esaurito consegnandolo presso uno dei punti di raccolta istituiti dalla propria società di smaltimento rifiuti comunale (ad es. centro di riciclo materiali). Il simbolo riportato qui a lato indica che non è assolutamente consentito smaltire l'apparecchio assieme ai normali rifiuti domestici! Secondo quanto previsto dalla legge sugli apparecchi elettrici ed elettronici, i proprietari di apparecchi esauriti sono per legge tenuti alla consegna di tutti gli **apparecchi elettrici ed elettronici** presso un centro di ri-lievo rifiuti in raccolta differenziata.



Consegnare gli accumulatori per lo smaltimento presso rivenditori al dettaglio di batterie o centri di raccolta che mettono a disposizione appositi contenitori.



Smaltire **confezioni ed imballaggi** in base a quanto indicato dalle norme in vigore a livello locale.

2 Mettere in funzione il telefono

Indicazioni di sicurezza



Attenzione: Prima della messa in funzione, leggere attentamente le indicazioni di sicurezza riportate al capitolo 1.

Verificare il contenuto della confezione

La confezione contiene:

Contenuto	Modello DF 100x			
	DF 1001	DF 1002 ¹	DF 1003 ¹	DF 1004 ¹
Stazione base con alimentatore di rete	1	1	1	1
Stazione di carica con alimentatore di rete	-	1	2	3
Unità portatile	1	2	3	4
Cavo di collegamento telefonico	1	1	1	1
Accumulatori	2	4	6	8
Istruzioni per l'uso	1	1	1	1

¹ Per ulteriori informazioni riguardo la disponibilità di questo set telefonico si prega di visitare il sito www.switel.com.

Mettere in funzione il telefono

Collegare la stazione base



Attenzione: Montare la stazione base con una distanza minima di 1 m da altri apparecchi elettronici in modo da evitare interferenze reciproche.

Procedere al collegamento della stazione base seguendo quanto raffigurato nella figura. Utilizzare per motivi di sicurezza solo l'alimentatore di rete oltre al cavo di collegamento telefonico fornito in dotazione.

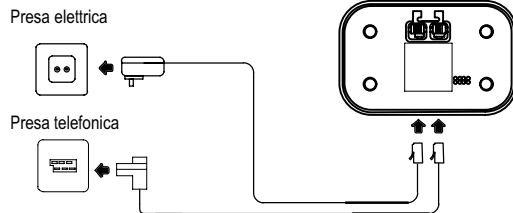

Attenzione: Utilizzare per la stazione base soltanto l'alimentatore con connettore trasparente e dati di output 7,5 V, 300 mA.

Collegare la stazione di carica²

Procedere al collegamento della stazione di carica seguendo la figura. Per motivi di sicurezza si prega di utilizzare soltanto l'alimentatore di rete fornito in dotazione.

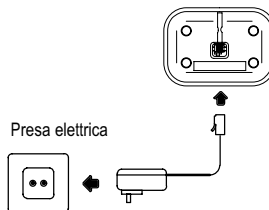

² Vale solo per set telefonici con minimo due unità portatili

☞ "Verificare il contenuto della confezione" a pagina 40.



La stazione base del vostro telefono è dotata di un circuito di alimentazione rete ad efficienza energetica SW-075030EU (Input 100-240 V_{AC}, Output 7,5 V_{DC}, 300 mA). Il carico nullo è pari a circa 0,2 W. L'efficienza media è pari a circa il 67 %. La potenza assorbita dalla stazione base ammonta a:

- in servizio (stand-by/conversazione): ca. 1,4 W
- durante la carica dell'unità mobile: ca. 2,2 W

La(e) stazione(i) di carica fornita(e) con un set telefonico è/sono dotata(e) di un circuito di alimentazione rete ad efficienza energetica SW-075020EU (Input 100-240 V_{AC}, Output 7,5 V_{DC}, 200 mA). Il carico nullo è pari a circa 0,2 W. L'efficienza media è pari a circa il 66 %.

La potenza assorbita dalla stazione di carica ammonta a:

- senza unità mobile: ca. 0,2 W
- durante la carica dell'unità mobile: ca. 1,1 W

Inserire gli accumulatori

Aprire il vano accumulatori. Inserire le batterie ricaricabili nel vano accumulatori precedentemente aperto. Utilizzare esclusivamente batterie ricaricabili di tipo AAA NiMH da 1,2 V. Osservare la corretta polarità! Chiudere quindi il vano accumulatori.

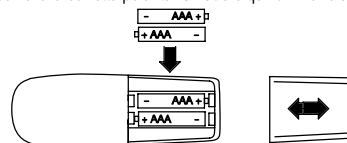

Caricare gli accumulatori



Riporre l'unità portatile in sede di prima messa in funzione per **minimo 15 ore** nella stazione base / stazione di carica.

Non appena il portatile è posizionato correttamente nella stazione base / stazione di carica, si avverte un segnale di avviso e la spia di controllo dello stato di carica si accende. L'unità portatile si surriscalda durante il processo di carica. Questo è un fenomeno normale e non pericoloso. Evitare di caricare l'unità portatile con dispositivi di carica differenti o estranei. Lo **stato di carica** attuale è visualizzato sul display:



Carico



Carico a metà



Scarico



Elementi di comando

Impostare la lingua di display

Selezionare la lingua che interessa (vedi anche "Struttura menu" a pagina 48):

Menü > Mobilteil-Einst. > Sprache >...

Menu > Imposta ric. > Lingua >...

Impostare data e ora dell'unità portatile

Una voce di menu consente di impostare data e ora. A pagina 50 è indicata la posizione da scorrere nel menu.

Accettazione di chiamata automatica (Auto-Talk)

L'attivazione di questa funzione consente di ricevere automaticamente una chiamata estraneo semplicemente l'unità portatile dalla stazione base. L'accettazione di automatica è attivata o disattivata nel menu. A pagina 52 è indicata la posizione nel menu.



Impianti telefonici interni

A pagina 47 sono riportate ulteriori informazioni nel caso in cui si volesse collegare il telefono ad un impianto telefonico interno.

Riduzione delle radiazioni (modalità ECO)

La radiazione in modalità di stand-by è stata considerevolmente ridotta se paragonata a quella emessa da telefoni cordless a standard DECT (con unità portatile nella base).

In modalità di conversazione le radiazioni sono ridotte in base alla distanza dell'unità portatile rispetto alla base.



Configurazione iniziale = Impostazioni → Imposta base → Mod. Ecologica → Disattivo

È possibile impostare il telefono in modo da ridurre l'emissione di radiazioni (pagina 52).



Se necessario è possibile aumentare la portata del sistema telefonico disattivando la modalità ECO.

3 Elementi di comando

I tasti del telefono riportati nel presente manuale d'istruzioni per l'uso sono raffigurati sotto forma di simboli uniformi all'interno di un riquadro. Sono possibili lievi scostamenti dei simboli dei tasti sul telefono rispetto ai simboli qui raffigurati.

Unità portatile

- 1 Ricevitore
- 2 Display
- 3 Tasto softkey di destra
- 4 Navigazione verso sopra / Ripetizione di chiamata
- 5 Tasto di riaggancio
- 6 Tasto / Blocco tastiera
- 7 Chiamate interne
- 8 Microfono
- 9 Tasto
- 10 Tasto / Selezione a toni temporanea
- 11 Tasto di chiamata / Funzione vivavoce
- 12 Navigazione verso sotto / Rubrica telefonica
- 13 Tasto softkey di sinistra
- 14 Altoparlante (sul retro)

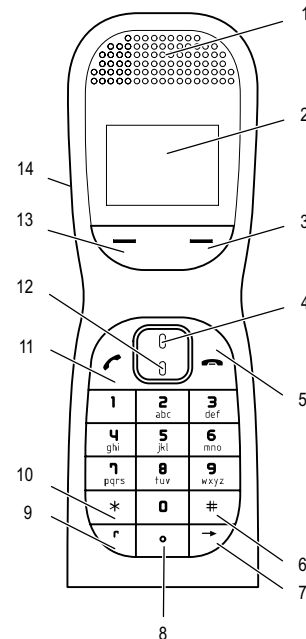

Stazione base (segreteria telefonica)

- 1 Contatti di carica
- 2 Cerca l'unità portatile (paging)
- 3 LED: Segnalazione dello stato di carica

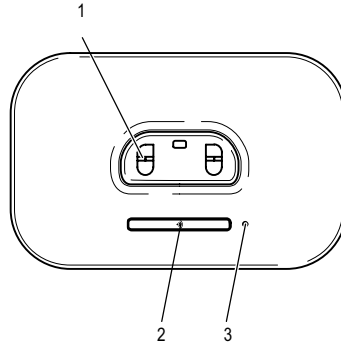

Stazione di carica¹

- 1 Contatti di carica
- 2 LED: Segnalazione dello stato di carica

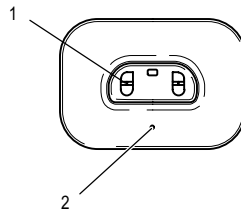

4 Informazioni introduttive

In questo capitolo sono riportate le principali informazioni riguardo l'uso delle presenti istruzioni e del telefono.

Modi di rappresentazione nelle istruzioni per l'uso

Rappresentazione	Descrizione
	Rappresentazione dei tasti
	Premere brevemente il tasto raffigurato
3 sec.	Premere il tasto raffigurato per 3 secondi
tenere	Tenere premuto il tasto raffigurato
rilasciare	Rilasciare il tasto raffigurato
	Inserire numeri o lettere
	Unità portatile squilla
	Stazione base squilla
	Estrarre l'unità portatile dalla stazione base
	Riporre l'unità portatile nella stazione base
	Rappresentazione di testi sul display
	Rappresentazione di simboli sul display
	Premere il tasto softkey pagina 44

¹ Vale solo per set telefonici con minimo due unità portatili
 "Verificare il contenuto della confezione" a pagina 40.

Informazioni introduttive

Simboli e testi sul display dell'unità portatile

Simbolo	Descrizione
	Indicazione dello stato di carica degli accumulatori
	Attivata la funzione allarme
	Volume di squillo = OFF
	Presenza di nuove chiamate nell'elenco chiamate ☞ pagina 54.
	Attivata la funzione vivavoce ☞ pagina 46.
	Attivato il blocco tastiera ☞ pagina 46.
	Segreteria telefonica integrata nella rete telefonica. VMWI ¹ - Servizio aggiuntivo del proprio gestore di rete telefonica ☞ pagina 47.
<div style="border: 1px solid black; padding: 2px;">Riserv. attiva</div>	Il microfono è in modalità silenziamento ☞ pagina 46.
	Costante: Il collegamento con la stazione base è buono. Lampeggiante: Il collegamento con la stazione base si interrompe. Avvicinarsi alla stazione base.
	Attivata la segreteria telefonica.
	Presenza di nuovi messaggi sulla segreteria telefonica.

¹ VMWI: Visual Message Waiting Indication = Segnalazione ottica di nuovi messaggi.

Modalità di stand-by

In tutte le descrizioni del presente manuale di istruzioni si considera l'unità portatile in modalità di stand-by. Per passare alla modalità di stand-by, premere il tasto .

Modalità di risparmio energetico

Trascorso un breve intervallo di tempo in modalità di stand-by, l'unità portatile passa in modalità di risparmio energetico. A questo punto, tasti e display non risultano più illuminati. Premere il tasto  per attivare la modalità di stand-by.

Tasti di navigazione

I tasti softkey (1) e (6) sono programmati con funzioni differenti in base al menu in cui ci si trova. Nelle presenti istruzioni per l'uso questi tasti sono denominati sempre in base ai testi di display visualizzati direttamente al di sopra.

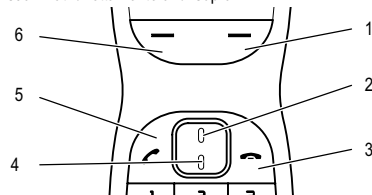







Tasto	In modalità di stand-by	Nel menu
1	- Aprire il menu Rubrica telefonica	- Navigazione indietro
2	- Aprire l'elenco di ripetizione di chiamata	- Navigazione verso sopra
3	- Attiva / Disattiva l'unità portatile	- Passaggio alla modalità di stand-by / Interrompe le operazioni
4	- Aprire la rubrica telefonica	- Navigazione verso sotto
5	- Tasto di chiamata / Funzione vivavoce	
6	- Aprire il menu principale	- Continua navigazione

Navigazione nel menu

I differenti menu consentono di raggiungere tutte le funzioni del telefono.







Il percorso da seguire per giungere alla funzione desiderata è indicata dalla struttura di menu ☞ pagina 48.

Menu	Aprire il menu principale
 /  SMS	Selezionare il sottomenu desiderato
Selez.	Aprire il sottomenu
 /  Scrivi messaggio	Selezionare la funzione richiesta
Selez.	Aprire la funzione
	La tastiera consente di inserire numeri o lettere
Opzioni	Confermare le immissioni
Indietro	Tornare indietro di un livello
	Interrompere le procedure di programmazione e memorizzazione e tornare indietro alla modalità di stand-by

 Ogni singolo processo si interrompe automaticamente se entro 30 secondi non si procede con una immissione.

Creare voci della rubrica telefonica - Esempio

La navigazione nei menu e la procedura da seguire per compiere impostazioni è indicata a titolo esemplificativo in **Creare voci nella rubrica telefonica**. Si consiglia di seguire quanto riportato nell'esempio per tutte le impostazioni che si desiderano compiere.

Rubrica	Aprire la rubrica telefonica
 /  Aggiungi voce	Selezionare il sottomenu e
Selez.	confermare
Inserisci nome: 	Inserire il nome (max. 12 cifre)
OK	e confermare
Inserisci numero: 	Inserire un numero di chiamata (max. 24 cifre) e confermare
Salva	
 / 	Selezionare la melodia di suoneria
Selez.	e confermare

5 Compiere telefonate

Accettare una chiamata

 /  Ricevere una chiamata

Concludere una chiamata

 Concludere una chiamata

Compiere telefonate

 Immettere un numero di chiamata (max. 24 cifre)

Cancello In caso di immissione errata cancellare l'ultima cifra

 Selezionare un numero di chiamata

 È altresì possibile premere il tasto di conversazione e ottenere quindi il segnale di linea libera. Le cifre immesse per la composizione del numero di chiamata desiderato sono immediatamente selezionate. Nel corso di una simile chiamata non è possibile eseguire la correzione di singole cifre che compongono il numero di chiamata.

Ripetizione di chiamata

Il telefono memorizza i 20 numeri di chiamata selezionati per ultimo in un elenco di ripetizione di chiamata.

 Aprire l'elenco di ripetizione di chiamata

 /  /  Selezionare una voce e instaurare un collegamento

Richiamare una telefonata ricevuta

Il telefono memorizza 30 chiamate nell'elenco chiamate.

Menu  / 
 Lista Chiamate, Selez. Aprire il menu Elenco chiamate

Chiamate perse o Chiam. ricevute,

Selez. Aprire l'elenco chiamate





 /  /  Selezionare una voce e instaurare un collegamento



Compiere telefonate

Selezionare numeri di chiamata dalla rubrica telefonica





Per fare questo è necessario aver precedentemente memorizzato dei numeri nella rubrica telefonica ➡ pagina 45 e 54.

	Aprire la rubrica telefonica
 /  , 	Selezionare una voce e instaurare un collegamento





Compiere chiamate interne¹

Condurre chiamate interne

Per condurre telefonate interne gratuite bisogna aver registrato due o più unità portatili (UP1, UP2, ...) presso la stazione base.

UP1:  , ad es.  , 	Selezionare il numero di chiamata interno dell'unità portatile desiderata
UP2: 	Accettare una telefonata interna presso l'altra unità portatile
UP1 / UP2: 	Concludere la telefonata interna

Trasferire internamente chiamate esterne





UP1:  , ad es.  , 	Selezionare con chiamata esterna in corso il numero interno
UP2: 	Accettare una telefonata interna presso l'altra unità portatile
UP1: 	Trasferire la telefonata



Nel caso in cui l'unità portatile chiamata non rispondesse, la telefonata esterna può essere di nuovo ripresa premendo il tasto .

Riscontro / Chiamata in attesa







Durante lo svolgimento di una chiamata esterna è possibile chiamare un'altra unità portatile allo scopo di consultarsi o eseguire un riscontro. Mentre è in corso la conversazione con l'interlocutore interno, la chiamata esterna è trattenuta. La procedura può essere ripetuta a piacere.

UP1:  , ad es.  , 	Selezionare con chiamata esterna in corso il numero interno
UP2: 	Accettare una telefonata interna presso l'altra unità portatile
UP1: 	Passare ad un altro interlocutore telefonico

¹ Per compiere telefonate interne sono necessarie minimo due unità portatili ➡ "Verificare il contenuto della confezione" a pagina 40.



Condurre chiamate a conferenza

Questa funzione consente di condurre una conferenza con una chiamata esterna ed un altro interlocutore interno.

UP1:  , ad es.  , 	Selezionare con chiamata esterna in corso il numero interno
UP2: 	Accettare una telefonata interna presso l'altra unità portatile
UP1 	Avviare una conferenza
UP1 / UP2: 	Concludere la chiamata in conferenza



Impostare il volume del ricevitore

Il volume è regolabile durante lo svolgimento di una chiamata in 8 livelli.

 / 	Selezionare il volume desiderato
---	----------------------------------

Funzione vivavoce

Utilizzare questa funzione per ascoltare il partner di chiamata attraverso l'altoparlante.



	Attivare la funzione vivavoce
	Disattivare la funzione vivavoce

Visualizzazione della durata di conversazione

Durante lo svolgimento di una chiamata, la durata della telefonata è visualizzata in minuti e secondi sul display.



Silenziamento del microfono nell'unità portatile

È possibile attivare e disattivare il microfono dell'unità portatile con chiamata telefonica in corso.

	Disattivare il microfono (silenziamento)
	Attivare il microfono

Blocco tastiera

Il blocco tastiera aiuta ad impedire l'attivazione inavvertita di determinate funzioni.

3 sec. 	Attivare il blocco tastiera
 , 	Disattivare il blocco tastiera



L'attivazione del blocco tastiera consente di ricevere telefonate in arrivo come di consueto.

Ricerca dell'unità portatile (funzione di paging)

Avendo perso d'occhio la propria unità portatile è possibile ritrovarla facilmente grazie all'emissione di un tono di ricerca.



Avviare il tono di ricerca



Interrompere il tono di ricerca

Attivare e disattivare l'unità portatile

Allo scopo di non sollecitare troppo gli accumulatori è possibile spegnere l'unità portatile.



3 sec.

Disattivare l'unità portatile



3 sec.

Attivare l'unità portatile

6 Impianti telefonici interni / Servizi aggiuntivi

Funzione R in impianti telefonici interni

Avendo collegato il telefono ad un impianto telefonico interno, il tasto **[R]** consente di accedere a tutte le altre funzioni disponibili come per es. trasferimento di chiamata e funzione di richiamata automatica. Si prega di consultare le istruzioni per l'uso del proprio impianto telefonico interno per individuare il tempo flash da impostare al fine di poter usufruire di queste funzioni. Il rivenditore autorizzato è in grado di indicare se il telefono acquistato funzionerà senza alcun problema nel proprio impianto telefonico interno. Il tempo flash è impostato tramite menu. Si rimanda alla pagina 52 dove è indicata la posizione (Tempo Flash) nel menu.

Funzione R e servizi aggiuntivi

Il telefono supporta servizi aggiuntivi messi a disposizione dal proprio gestore di rete telefonica come ad es. le funzioni di chiamata in attesa, avviso di chiamata e chiamata a conferenza. Il tasto **[R]** consente di accedere ai servizi aggiuntivi. Si prega di consultare il proprio gestore di rete telefonica per ottenere informazioni sul tempo flash necessario all'utilizzo dei servizi aggiuntivi. Rivolgersi al proprio gestore di rete telefonica per ottenere l'abilitazione ai servizi aggiuntivi. Il tempo flash è impostato tramite menu. Si rimanda alla pagina 52 dove è indicata la posizione (Tempo Flash) nel menu.

Impianti telefonici interni / Servizi aggiuntivi

Visualizzazione del numero di chiamata (CLIP¹)



La visualizzazione del numero di chiamata è un servizio aggiuntivo offerto dal proprio gestore di rete telefonica. Si consiglia di rivolgersi al proprio gestore di rete telefonica per ricevere ulteriori informazioni a riguardo.

A condizione che il collegamento telefonico disponga di questa funzione, l'apparecchio visualizza il numero telefonico del chiamante non appena il telefono squilla.

Nel caso in cui il chiamante abbia soppresso la trasmissione del proprio numero di chiamata, appare un'apposita indicazione. Se il numero di chiamata non è visualizzabile, questo non sarà memorizzato nell'elenco chiamate.

Pausa di selezione

In presenza di impianti telefonici interni è necessario preselezionare un numero di accesso alla rete esterna per ottenere un segnale di linea libera prima di poter compiere una telefonata. Alcuni impianti telefonici interni di vecchia data richiedono del tempo prima di trasmettere il segnale di libero. Per questi impianti telefonici interni è possibile inserire una pausa di selezione dopo il numero di accesso alla linea esterna in modo da poter proseguire con la selezione del numero senza dover attendere il segnale di libero.



3 sec.

Inserire una pausa di selezione

Dopo il numero di accesso alla rete esterna si procede, trascorso un determinato intervallo di tempo, con la selezione del numero di chiamata vero e proprio.



La pausa di selezione è memorizzabile anche in sede di immissione di numeri di chiamata nella rubrica telefonica.

Segreteria telefonica integrata nella rete telefonica

Sono numerosi i gestori di rete telefonica che offrono come servizio aggiuntivo una segreteria telefonica integrata nella stessa rete. Se il proprio gestore di rete telefonica mette a disposizione una segreteria telefonica all'interno della propria rete telefonica, un simbolo informa sulla presenza di nuovi messaggi (VMWI²). Questa funzione è disponibile solo nel caso di abilitazione al servizio da parte del gestore di rete telefonica. Per maggiori dettagli a riguardo, rivolgersi al proprio gestore di rete telefonica.

¹ CLIP: Calling Line Identification Presentation = Visualizzazione del numero telefonico del chiamante.



² VMWI: Visual Message Waiting Indication = Segnalazione ottica di nuovi messaggi.

Struttura del menu

7 Struttura del menu

Menu principale

Nel menu principale si giunge premendo il tasto softkey **Menu**. La procedura da seguire per scorrere all'interno del menu ed eseguire immissioni è riportata a pagina 44.

SMS	Scrivi messaggio		Opzioni	Invia	Inserisci numero: 	Invia
				Salva		
				Inserisci simbolo		
				Inserisci icona		
				Inserisci modello		
	Msg ricevuti	Leggi	Opzioni	Rispondi		
				Inoltra		
				Dettagli msg.		
				Usa numero		
				Elimina		
	Bozze	Modifica	Opzioni	vedi Scrivi messaggio		
	Msg inviati	Leggi	Opzioni	Inoltra		
				Elimina	Si / No	
	Modelli	Opzioni	Modifica			
				Elimina	Si / No	
	Elimina messaggi	Msg ricevuti	Si / No			
		Bozze	Si / No			
		Msg inviati	Si / No			
		Tutti i messaggi	Si / No			

Impostazioni SMS	Centro servizi	Imp.centro invio	Centro invio 1		
			Centro invio 2		
		Centro ricezione	Centro ricez. 1 - 2	Inserisci numero:	Salva
		Centri invio	Centro invio 1 - 2	Inserisci numero:	Salva
	N. casella posta				Salva
	Dimensione msg.	160 caratteri			
		612 caratteri			
	Avviso messaggio	Attivo / Disattivo			
	Utenti	Utente 1 - 4	Opzioni	Modifica	Inserisci nome:
				Elimina	Si / No



Lista Chiamate	Chiamate perse	Opzioni	Mostra dettagli		
			Salva numero	Inserisci nome:	Inserisci numero:
			Invia messaggio		
			Elimina chiamata		
	Chiam. ricevute	Opzioni	vedi Chiamate perse		
	Chiam.effettuate	Opzioni	vedi Chiamate perse		
	Elimina chiamate	Chiamate perse, Chiam. ricevute, Chiam.effettuate			Si / No



Struttura del menu

Agenda	Opzioni	Aggiungi evento	Inserisci data:	Inserisci ora:	Silenzioso	
					Sveglia	Una volta / Annualmente
		Mostra dettagli				
		Modifica evento	Inserisci data:	Inserisci ora:	Silenzioso	
					Sveglia	Una volta / Annualmente
		Invia come testo	Opzioni	Invia	Inserisci numero:	Invia
				Salva		
				Inserisci simbolo		
				Inserisci icona		
				Inserisci modello		
		Elimina evento	Eliminare evento?	Si / No		
		Elim.tutti eventi	Eliminare tutti gli eventi?		Si / No	

Orologio	Data e ora	Inserisci data:	Inserisci ora:
	Sveglia	Disattivo / Attivo	
	Formato ora	12 ore	
		24 ore	

Impostazioni	Imposta ric.	Suoneria	Chiamata esterna	Melodia 1 - 20
			Chiamata interna	Melodia 1 - 20
		Volume suoneria	Suon. disat.	
			Volume 1 - 5	
		Volume ricevitore	Volume 1 - 8	
		Nome ricevitore		
		Lingua	English (UK)	
			Français	
			Deutsch	
			Italiano	
			Español	
		Screen saver	Orologio / Disattivo	
		Timeout luce	15 secondi	
			30 secondi	
			45 secondi	
		Chiam. automatica	Disattivo / Attivo	
		Toni di tastiera	Disattivo / Attivo	
		Cod. accesso PABX	Disattivo / Attivo	
			Imposta codice	

Struttura del menu

Imposta base	Suoneria	Melodia 1 - 5		
		Suoneria predef.		
	Volume suoneria	Suon. disat.		
		Volume		
	Modalità chiamata	Impulsi		
		Toni		
	Tempo Flash	Ora flash 1		
		Ora flash 2		
	Primo squillo	Attivo / Disattivo		
	PIN sistema	Ins.vecchio PIN:	Ins.nuovo PIN:	Ripetere PIN:
	Ripristina originale	Confermi?	SI / No	Ins.PIN sistema:
	Mod. Ecologica	Disattivo / Attivo		

Registrazione	Registra ricev.	Base 1 - 4	Ins.PIN sistema:
	Seleziona base	Base 1 - 4	Ins.PIN sistema:
	Annulla registr.		

Rubrica	Opzioni	Mostra dettagli				
		Invia messaggio	Opzioni	Invia	Inserisci numero:	Invia
				Salva		
				Inserisci simbolo		
				Inserisci icona		
				Inserisci modello		
		Modifica voce	Inserisci nome:	Inserisci numero:	Melodia 1- 20	
					Suoneria predef.	
		Copia voce	A port. o Base			
		Suoneria	Melodia 1 - 20			
			Suoneria predef.			
		Elimina voce	Si / No			
		Chiamata rapida	Tasto 1 - 3	Assegna		
				Annulla voce		
		Aggiungi voce	Inserisci nome:	Inserisci numero:	Melodia 1- 20	
					Suoneria predef.	
		Copia rubrica	A port. o Base			
		Stato memoria				
		Elimina rubrica	Eliminare tutte le voci?	Si / No		

Rubrica telefonica



8 Rubrica telefonica

Nella rubrica telefonica è possibile memorizzare 250 numeri di chiamata con rispettivi nomi.

- Le voci della rubrica telefonica sono elencate in ordine alfabetico. Per accedere direttamente alla voce della rubrica telefonica desiderata, premere la lettera iniziale corrispondente.

Immettere nomi

I tasti numerici riportano altresì delle lettere. Premendo ripetutamente il relativo tasto si ha modo di selezionare lettere, cifre e caratteri speciali.

	Immettere spazi vuoti
Cancel	Cancelare
 oppure 	Inserire caratteri speciali











Per immettere la stessa lettera una seconda volta, premere il rispettivo tasto. Attendere fino a quando il cursore si sia spostato di una posizione. Immettere quindi la lettera una seconda volta.

Creare voci della rubrica telefonica

Vedi esempio  pagina 45.







Modificare le voci della rubrica telefonica

Rubrica	Aprire il menu principale
 /  <input type="text" value="Cerca"/>	Selezionare la rubrica telefonica e confermare
Selez.	
 /  Opzioni	Selezionare la voce della rubrica telefonica e confermare
 /  <input type="text" value="Modifica voce"/>	Selezionare il sottomenu e confermare
Selez.	
<input type="text" value="Inserisci nome:"/> 	Modificare il nome e confermare
<input type="text" value="Inserisci numero:"/> 	Modificare il numero di chiamata e confermare
Salva	confermare
<input type="text" value="Melodia 1 - 20"/>	Selezionare la melodia di suoneria e salvare
Selez.	



¹ CLIP: Calling Line Identification Presentation = Visualizzazione del numero telefonico del chiamante.

Cancelare le voci della rubrica telefonica

Cancelare una voce

Rubrica	Aprire il menu principale
 /  <input type="text" value="Cerca"/>	Selezionare la rubrica telefonica e confermare
Selez.	
 /  Opzioni	Selezionare la voce della rubrica telefonica e confermare
 /  <input type="text" value="Elimina voce"/>	Selezionare il sottomenu e confermare
Selez.	
<input type="text" value="Eliminare?"/> Si / No	Confermare o interrompere la procedura di cancellazione

Cancelare tutte le voci

Rubrica	Aprire il menu principale
 /  <input type="text" value="Elimina rubrica"/>	Selezionare il sottomenu e confermare
Selez.	
<input type="text" value="Eliminare tutte le voci?"/>	Procedura di cancellazione
Si / No	Confermare o interrompere



9 Elenco chiamate

All'interno dell'elenco chiamate è possibile memorizzare complessivamente 30 numeri telefonici.



La visualizzazione del numero di chiamata (CLIP¹) è un servizio aggiuntivo del proprio gestore di rete telefonica. Nel caso in cui il gestore di rete telefonica supporti il servizio, sul display del telefono è visualizzato il numero di chiamata. Per maggiori dettagli a riguardo, rivolgersi al proprio gestore di rete telefonica.

Visualizzare/Chiamare numeri dall'elenco chiamate

Menu	Aprire il menu principale
 /  <input type="text" value="Lista Chiamate"/>	Selezionare il sottomenu e confermare
Selez.	

Chiamate perse	o	Chiam. ricevute	,
Selez.		Aprire l'elenco chiamate	
	Selezionare un numero di chiamata		

Memorizzare nella rubrica telefonica un numero di chiamata presente nell'elenco chiamate

È possibile memorizzare un numero di chiamata direttamente dall'elenco chiamate nella rubrica telefonica.

Menu	Aprire il menu principale		
/	Lista Chiamate	,	Selezionare il sottomenu e
Selez.		confermare	
Chiamate perse	o	Chiam. ricevute	,
Selez.		Aprire l'elenco chiamate	
/	Opzioni	Selezionare la voce e confermare	
Salva numero	,	Selez.	Aprire la funzione
Inserisci nome:		OK	Immettere il nome (max. 12caratteri) e confermare
Inserisci numero:		Modificare il numero di chiamata	
Salva		e confermare	
Melodia 1 - 20	Selezionare la melodia di suoneria		
Selez.		e salvare	

Cancelare i numeri di chiamata dall'elenco chiamate

Cancelare singoli numeri di chiamata

Menu	Aprire il menu principale		
/	Lista Chiamate	,	Selezionare il sottomenu e
Selez.		confermare	
Chiamate perse	o	Chiam. ricevute	,
Selez.		Aprire l'elenco chiamate	

/	Opzioni	Selezionare la voce e confermare	
Elimina chiamata	,	Selez.	Confermare la funzione
Cancelare tutti i numeri di chiamata			
Menu		Aprire il menu principale	
/	Lista Chiamate	,	Selezionare il sottomenu e
Selez.		confermare	
/	Elimina chiamate	Aprire il sottomenu	
Chiamate perse	o	Chiam. ricevute	o
Chiam. effettuate	o	Tutte chiamate	,
Selez.		Selezionare l'elenco chiamate	
Eliminare tutte le chiamate?		Procedura di cancellazione	
Sì / No		Confermare o interrompere	

10 Funzioni speciali

Procedura di selezione

Il presente telefono funziona sia all'interno di sistemi telefonici analogici (procedura di selezione a impulsi), sia se integrato in moderni sistemi telefonici digitali (procedura di selezione a toni). La procedura di selezione è impostata tramite menu. A pagina 52 è indicata la posizione da scorrere nel menu.

Selezione a toni temporanea

Qualora fosse possibile utilizzare il telefono soltanto con la procedura di selezione a impulsi, non sarà necessario rinunciare ai vantaggi della procedura di selezione a toni (ad es. per l'interrogazione della segreteria telefonica dalla rete telefonica). Con chiamata in corso è possibile passare temporaneamente alla procedura di selezione a toni.

2 sec. Premere con chiamata in corso

A conclusione della chiamata il telefono passa di nuovo automaticamente alla procedura di selezione a impulsi.

Allarme

Con la funzione è possibile farsi svegliare dalla propria unità portatile all'orario precedentemente impostato. A pagina 50 è indicata la posizione da scorrere nel menu.

Agenda

Il telefono consente di memorizzare fino a 5 eventi (ad es. date di compleanni) con funzione di segnalazione il giorno interessato. Gli eventi possono avere una lunghezza di fino a 24 caratteri.

Creare voci nell'agenda

Menu	Aprire il menu principale
<input type="button" value="v"/> / <input type="button" value="^"/> <input type="text" value="Agenda"/>	Selezionare l'agenda
Selez.	e confermare
Opzioni	<input type="text" value="Aggiungi evento"/>
Selez.	e confermare
Salva	Inserire l'evento e confermare
Salva	Inserire la data e confermare
Salva	Inserire l'ora e confermare
<input type="button" value="v"/> / <input type="button" value="^"/> <input type="text" value="Silenzioso"/> o	
Sveglia	Selez.
Selezionare il tipo di segnalazione desiderata e confermare	
Per scegliere <input type="text" value="Sveglia"/> :	
<input type="button" value="v"/> / <input type="button" value="^"/> <input type="text" value="Una volta"/> o	
Annualmente	Selez.
Selezionare l'intervallo e confermare	
<input type="button" value="v"/> / <input type="button" value="^"/> <input type="text" value="All'ora definita"/> o	
30 min prima	Selez.
Selezionare l'ora di segnalazione e confermare	

Ulteriori esempi di funzionamento sono riportati nella struttura menu a pagina 50.

¹ **CLIP**: Calling Line Identification Presentation = Visualizzazione del numero telefonico del chiamante.

² **SMS**: Short Message Service = Servizio per l'invio di messaggi di testo brevi.

11 SMS

Requisiti SMS

L'allacciamento telefonico deve essere abilitato alla caratteristica funzionale **CLIP**¹. Assicurarci presso il proprio gestore di rete telefonica, che l'allacciamento telefonico sia abilitato alla caratteristica funzionale richiesta. Per poter usufruire del servizio **SMS**² può rendersi necessaria la precedente abilitazione al servizio presso il proprio gestore di rete telefonica.

- L'invio di SMS non è possibile da qualsiasi tipo di impianto telefonico interno.



Volendo compiere l'invio di un SMS da un impianto telefonico interno, memorizzare sull'unità portatile prima la cifra per il segnale dalla centrale richiesto dal proprio impianto telefonico, quindi il numero del centro di servizi.

- L'invio di SMS non è attualmente possibile in caso di collegamenti call by call.
- L'invio di messaggi SMS è soggetto a costi supplementari.
- Se il ricevitore non utilizza un servizio SMS su rete fissa o se il rispettivo telefono non è abilitato alla ricezione di SMS, il messaggio SMS è inoltrato sotto forma di messaggio vocale.
- Il calcolo delle rispettive spese avviene da parte del proprio gestore di rete telefonica.

Centro di servizi SMS

La distribuzione dei messaggi SMS è eseguita da parte di un centro di servizi. Volendo inviare dei messaggi di testo in formato SMS è necessario programmare il numero del centro di servizi nella propria unità portatile pagina 11. Il numero del centro di servizi necessario è comunicato dal provider prescelto che provvederà altresì ad indicare la procedura da seguire per l'abilitazione al servizio SMS.



Il telefono è predisposto per l'invio di messaggi di testo SMS. Alcuni numeri di centri di servizi SMS risultano già programmati sull'unità portatile. Basta attivare il centro di servizi SMS desiderato nel menu SMS pagina 11.

Centro invio 1

Swisscom: 0622100000

Centro invio 2

Cablecom: 043537370

Immettere testi

Sui tasti a cifra si trovano altresì delle lettere per l'immissione di testi. Premendo ripetutamente il relativo tasto si ha modo di selezionare lettere, cifre e caratteri speciali. La navigazione che consente di scrivere dei messaggi SMS è riportata nella struttura menu pagina 48.



Passare da lettere maiuscole a lettere minuscole e viceversa

Cancel

Cancel

3 sec

Cancella

Cancellare tutto

Modelli SMS

Sono disponibili 5 modelli di testo preconfigurati ➤ pagina 48.

Segnale di avviso SMS (allarme)

La ricezione di messaggi di testo SMS nuovi è segnalato acusticamente con un segnale di avviso. Il segnale è attivato o disattivato tramite menu. A pagina 11 è indicata la posizione da scorrere nel menu.

12 Ampliamento del sistema telefonico

Lo standard internazionale **GAP**¹ regola la compatibilità di unità portatili e stazioni base di costruttori differenti. In tal modo è possibile adoperare apparecchi SWITEL in combinazione con apparecchi di altri costruttori all'interno di un unico sistema telefonico. Può comunque anche verificarsi la mancata disponibilità di alcune funzioni.

Maggior numero di unità portatili

La stazione base prevede la registrazione di complessivamente 5 unità portatili.

Registrazione di unità portatili

Prima di registrare un'unità portatile, passare con la stazione base alla modalità di registrazione. Tenere premuto il tasto di paging sulla base fino ad avvertire un segnale acustico. A questo punto la base è in modalità di registrazione per una durata di 60 secondi. Procedere con l'unità portatile.

2 sec. 

Avviare la modalità di registrazione

Procedere a questo punto con la registrazione dell'unità portatile ➤ pagina 53. Utilizzare per la registrazione il codice PIN attualmente impostato ➤ pagina 52.

Una volta eseguita la selezione, all'unità portatile è assegnato un numero di chiamata interno.



Per registrare unità portatili di altri costruttori, leggere prima le rispettive istruzioni per l'uso.

Deregistrazione di unità portatili



Ogni unità portatile può compiere la deregistrazione di un'unità portatile registrata presso la stessa unità base.

Unità portatili sono deregistrate nel menu. A pagina 53 è indicata la posizione da scorrere nel menu.

¹ **GAP**: Generic Access Profile = Standard per l'interazione di unità portatili e stazioni base di altri costruttori.

Ampliamento del sistema telefonico

Maggior numero di stazioni base

La portata della propria unità portatile può essere aumentata registrando l'apparecchio ad un numero maggiore di stazioni base. È possibile registrarsi contemporaneamente presso 4 stazioni base differenti. Ogni stazione base necessita di una propria presa telefonica. Si può trattare di allacciamenti con lo stesso o differente numero di chiamata.



Per chiamate in corso non è invece possibile compiere un trasferimento da una stazione base all'altra.

13 In presenza di problemi

Linea di assistenza

In presenza di problemi con il telefono, seguire le indicazioni riportate qui di seguito. In caso di problemi tecnici è possibile rivolgersi alla nostra linea di assistenza tecnica chiamando al numero 0900 00 1675 valido per la Svizzera (spese da rete Swisscom alla data di stampa: CHF 2,60/min). In caso di reclami entro il periodo di garanzia, rivolgersi al rivenditore autorizzato. Il periodo di garanzia ricopre 2 anni.

Domande e risposte

Domande	Risposte
Non è possibile instaurare un collegamento con la stazione base	<ul style="list-style-type: none"> - Verificare se la registrazione alla stazione base è stata eseguita con il codice PIN corretto ➤ pagina 52.
Non è possibile condurre una chiamata telefonica	<ul style="list-style-type: none"> - Il telefono non è collegato correttamente oppure presenta un guasto. Utilizzare esclusivamente il cavo di collegamento telefonico fornito. - Provare con un altro telefono se l'allacciamento telefonico in questione è funzionante. - L'alimentatore di rete non è inserito oppure si è in presenza di una caduta di tensione totale. - L'accumulatore ricaricabile è scarico o difettoso. - La distanza dalla stazione base è troppo grande. - Procedura di selezione non impostata correttamente ➤ pagina 52.

Specifiche tecniche

Collegamento disturbato, interrotto	<ul style="list-style-type: none">- La distanza dalla stazione base è troppo grande.- Luogo di installazione della stazione base errato.
Il sistema non reagisce più	<ul style="list-style-type: none">- Selezionare "Ripristina originale" per tutte le funzioni ripristinando la configurazione iniziale  pagina 52.- Estrarre brevemente l'alimentatore di rete dalla presa di corrente.
Le batterie ricaricabili si scaricano piuttosto subito	<ul style="list-style-type: none">- Le batterie ricaricabili sono scariche o difettose.- Riporre l'unità portatile correttamente nella stazione base. Pulire le superfici di contatto su unità portatile e stazione base con un panno morbido e asciutto.- Posizionare l'unità portatile per la durata di 15 ore nella stazione base.
La visualizzazione del numero di chiamata (CLIP ¹) non funziona	<ul style="list-style-type: none">- La visualizzazione del numero di chiamata è un servizio aggiuntivo offerto dal proprio gestore di rete telefonica. Per maggiori dettagli a riguardo, rivolgersi al proprio gestore di rete telefonica.- Il chiamante ha disattivato la trasmissione del proprio numero di chiamata.

¹ **CLIP**: Calling Line Identification Presentation = Visualizzazione del numero telefonico del chiamante.

14 Specifiche tecniche

Specifiche tecniche

Caratteristica	Valore
Standard	DECT ¹ -GAP ²
Alimentazione elettrica (stazione base, connettore trasparente)	Ingresso: 100-240 V, 50/60 Hz Uscita: 7,5 V 300 mA
Alimentazione elettrica (stazione di carica, connettore rosso)	Ingresso: 100-240 V, 50/60 Hz Uscita: 7,5 V 200 mA
Portata	Esterno: ca. 300 m Interno: ca. 50 m
Modalità di stand-by	fino a 100 ore
Max. durata di conversazione	fino a 10 ore
Accumulatori ricaricabili	AAA NiMH 1,2 V
Procedura di selezione	Selezione a toni Selezione a impulsi
Temperatura ambiente ammessa	Normale: da 15 °C a 35 °C Estremo: da 0 °C a 40 °C
Umidità dell'aria relativa ammessa	da 0% a 90%
Tempi flash	100 ms, 300 ms

¹ **DECT**: Digital Enhanced Cordless Telecommunication = Standard per telefoni senza cavo.

² **GAP**: Generic Access Profile = Standard per l'interazione di unità portatili e stazioni base di altri costruttori.

Configurazione iniziale

Unità portatile

Sveglia	Disattivo
Volume suoneria	Volume5
Suoneria Chiamata esterna / Suoneria Chiamata interna	Melodia 1 / Melodia 2
Volume ricevitore	Volume4
Toni di tastiera	Attivo
Screen saver	Disattivo
Lingua	Deutsch
Nome ricevitore	DF 1001
Chiam.automatica	Attivo
Formato ora	24 ore

Stazione base

La configurazione iniziale è ripristinata nel menu.
A pagina 52 è indicata la posizione da scorrere nel menu.

Modalità chiamata	Toni
Tempo flash (Tempo Flash)	100 ms (Ora flash 1)
PIN sistema	0000

Dichiarazione di conformità

Questo apparecchio risponde a quanto disposto dalla Direttiva UE: 1999/5/CE concernente le apparecchiature radio, le apparecchiature terminali di telecomunicazioni e il reciproco riconoscimento della loro conformità. La conformità con la Direttiva di cui sopra viene confermata dal marchio CE applicato sull'apparecchio. Per la dichiarazione di conformità completa si prega di voler usufruire del servizio gratuito di download dal nostro sito Internet www.switel.com.



15 Consigli per la cura / Garanzia

Consigli per la cura

- Pulire le superfici degli apparecchi con un panno morbido e antipelucchi.
- Non utilizzare mai detergenti o solventi.

Garanzia

Gli apparecchi SWITEL sono costruiti e collaudati in osservanza dei processi di produzione più moderni. L'impiego di materiali selezionati e tecnologie altamente sviluppate sono garantiti di una perfetta funzionalità e lunga durata in vita. La garanzia non viene considerata esecutiva qualora la causa del malfunzionamento dell'apparecchio sia riconducibile al gestore della rete telefonica oppure se questa è da attribuirsi ad un impianto telefonico interno interposto. La garanzia non si estende a batterie, accumulatori o pacchi batteria utilizzati all'interno degli apparecchi. Il periodo di garanzia ricopre 24 mesi a partire dalla data di acquisto.

Entro il periodo di garanzia si procederà all'eliminazione gratuita di tutti i guasti dovuti a difetti di materiale o produzione. Il diritto di garanzia cessa in caso di interventi da parte dell'acquirente o di terzi. Danni derivanti da un impiego o esercizio non conforme agli usi previsti, a naturale usura, a errato montaggio o errata conservazione, a collegamento o installazione impropri, dovuti a forza maggiore o ad altri influssi esterni non sono coperti da garanzia. In qualità di produttore ci riserviamo il diritto, in caso di reclami, di riparare o sostituire le parti difettose o di rimpiazzare l'apparecchio. Parti o apparecchi sostituiti passano di nostra proprietà. Sono esclusi diritti di risarcimento per danni qualora non siano dovuti a intenzione o colpa grave del costruttore.

Nel caso in cui il presente apparecchio dovesse, nonostante presentare un difetto durante il periodo di garanzia, si prega di rivolgersi esclusivamente al negozio di rivendita dell'apparecchio SWITEL assieme al relativo scontrino di acquisto. In base alle presenti disposizioni, tutti i diritti di garanzia dovranno essere fatti valere esclusivamente nei confronti del rivenditore autorizzato. Decorso il termine di due anni dalla data di acquisto e consegna dei nostri prodotti non sarà più possibile fare valere alcun diritto di garanzia.



Safety Information

1 Safety Information

Please read this operating instruction manual thoroughly.

Intended use

The telephone is suitable for telephoning within a public telephone network system. Any other use is considered unintended use. Unauthorised modification or reconstruction is not permitted. Under no circumstances open the device or complete any repair work yourself.

Installation location

Prevent excessive exposure to smoke, dust, vibration, chemicals, moisture, heat and direct sunlight.

Do not use the handset in potentially explosive areas.

Power adapter plug



Attention: Only use the power adapter plug supplied because other power supplies could damage the telephone. Ensure access to the power adapter plug is not obstructed by furniture or such.

Rechargeable batteries



Attention: Never throw batteries into a fire. Only use batteries of the same type. Pay attention to correct polarity. Incorrect polarity of the batteries represents a risk of explosion during charging.

Power failure

The telephone cannot be used to make calls in the event of a power failure. Always keep a wired telephone which operates without an external power supply available in case of emergency situations.

Medical equipment



Attention: Never use the telephone in the vicinity of medical equipment. Effects on such equipment cannot be fully ruled out.

DECT¹ telephones can cause an unpleasant humming sound in hearing aids.

Hearing aid compatible

The telephone is compatible with most popular hearing aids on the market. However, it cannot be guaranteed that all hearing aids will work perfectly.

Disposal

In order to dispose of your device, take it to a collection point provided by your local public waste authorities (e.g. recycling centre). The adjacent symbol indicates that the device must not be disposed of in normal domestic waste! According to laws on the disposal of electronic and electrical devices, owners are obliged to dispose of old **electronic and electrical devices** in a separate waste container.

Batteries must be disposed of at the point of sale or at the appropriate collection points provided by the public waste authorities.

Packaging materials must be disposed of according to local regulations.



2 Preparing the Telephone

Safety information



Attention: It is essential to read the Safety Information in Chapter 1 before starting up.

Checking the package contents

The package contains:

Content	Model DF 100x			
	DF 1001	DF 1002 ¹	DF 1003 ¹	DF 1004 ¹
Base station with power adapter plug	1	1	1	1
Charging station with power adapter plug	-	1	2	3
Handset	1	2	3	4
Telephone connection cable	1	1	1	1
Batteries	2	4	6	8
Operating instructions	1	1	1	1

¹ DECT: Digital Enhanced Cordless Telecommunication = Standard for cordless telephones.

¹ Visit www.switel.com to find out whether the telephone set is already available.

Preparing the Telephone

Connecting the base station



Attention: Position the base station at least 1 m away from other electronic devices, otherwise there is a risk of mutual disturbance.

Connect the base station as illustrated in the diagram. For reasons of safety, only use the power adapter plug and telephone connection line supplied.

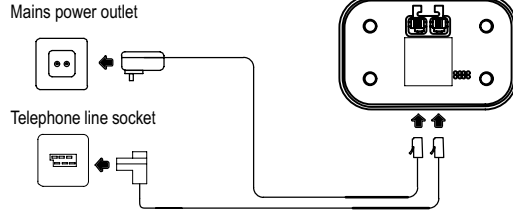

Attention: Use the adapter with the transparent plug to connect the base. The adapter is rated at (Output 7.5 V, 300 mA).

Connecting the charging station ²

Connect the charging station as illustrated in the diagram. For safety reasons, only use the power adapter plug supplied.

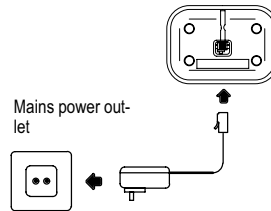

Your phone's base station is supplied with an energy-efficient switching power supply SW-075030EU (Input 100~240 V_{AC}, Output 7,5 V_{DC}, 300 mA). The adaptor input power without load is approx. 0.2 W. The average efficiency is approx. 67 %. The electrical consumption of the base is:

- in operation mode (idle/call): approx. 1.4 W
- during charging of the handset: approx. 2.2 W

The charger(s) delivered with a telephone set is/are supplied with an energy-efficient switching power supply SW-075020EU (Input 100~240 V_{AC}, Output 7.5 V_{DC}, 200 mA). The adaptor input power without load is approx. 0.2 W. The average efficiency is approx. 66 %.

The electrical consumption of the charger is:

- without handset charging: approx. 0.2 W
- during charging of the handset: approx. 1.1 W

Inserting the batteries

Open the battery compartment cover. Insert the batteries in the open battery compartment. Only use batteries of the type AAA NIMH 1.2 V. Pay attention to correct polarity. Close the battery compartment.

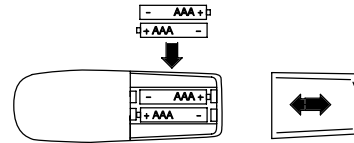

Charging the batteries



Before the handset is used for the first time, insert it in the base/charging station for **at least 15 hours**.

When the handset is inserted in the base/charging station properly, you will hear an acoustic confirmation signal and the charge control lamp lights up. The handset warms up during the charging process. This is normal and does not represent a risk. Do not charge the handset with charging units from other manufacturers. The current **battery charge status** is indicated in the display:



Full



Semi-discharged



Empty

² Only applies to telephone sets with at least two handsets
☞ "Checking the package contents" on Page 60.

Operating Elements

Setting the display language

Select the language required (see "Menu Structure" on Page 68):

Menü > Mobilteil-Einst. > Sprache >...

Menu > Set Handset > Language >...

Setting the date and time on the handset

The time and date are set via the menu. Refer to Page 70 for the sequence of menu option selections.

Auto answer (Auto-Talk)

If this function is activated, an incoming call is taken when the handset is near the base station. The automatic answering function is activated and deactivated via the menu. Refer to Page 71 for the sequence of menu option selections.



Private branch exchanges

The information on Page 67 explains how to install your telephone in a private branch exchange.

Low-radiation operation (ECO mode)

The level of radiation is considerably lower than that of standard DECT cordless telephones when in Standby mode (when the handset is in the base station).

In talk mode, radiation is reduced (depending on the distance between the handset and base station).

 Default setting = Settings → Set Base → ECO Mode → Off









The telephone can be set up so that the radiation frequency is reduced; see Page 71.

 If necessary, you can increase the range of the telephone system by switching ECO mode off.

3 Operating Elements

The buttons in this operating manual are subsequently depicted with a uniform contour. Therefore, slight deviations in the appearance of the symbols on the telephone buttons compared to those depicted here are possible.

Handset

- 1 Receiver
- 2 Display
- 3 Softkey, right
- 4  Scroll upwards / Redialling
- 5  On-hook button
- 6  # button / Key lock
- 7  Internal calls
- 8 Microphone
- 9  R button
- 10  * button / Temporary tone dialling
- 11  Call button / Handsfree
- 12  Scroll downwards / Phone book
- 13 Softkey, left
- 14 Loudspeaker (on rear side)

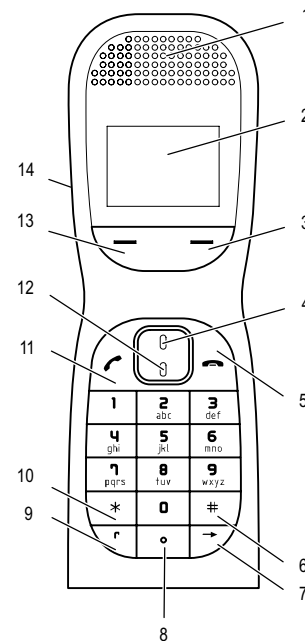

Base station

- 1 Charging contacts
- 2 Locate handset (paging)
- 3 LED: Charging control lamp

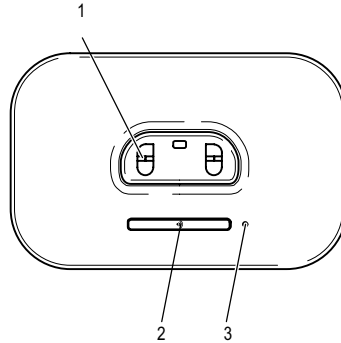

Charging station¹

- 1 Charging contacts
- 2 LED: Charging control lamp

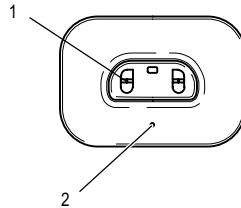

4 Preliminary Information

This chapter provides basic information on using the operating instruction manual and the telephone.











Description of operating sequences in the manual

Display	Description
	Displays the contour of buttons
	Press the button depicted briefly
3 sec.	Press the button depicted for 3 seconds
hold	Press and hold the button depicted
release	Release the button depicted
	Enter digits or letters
	Handset rings
	Base station rings
	Remove the handset from the base station
	Place the handset in the base station
	Depicts text in the display
	Depicts icons in the display
	Press the softkey Page 64

¹ Only applies to telephone sets with at least two handsets
 "Checking the package contents" on Page 60.

Preliminary Information

Icons and texts in the handset display

Icon	Description
	Displays current battery charge capacity
	Alarm function is activated
	Ringing volume = Off
	New calls have been registered in the CID book (calls log); ☞ Page 73.
	The handsfree facility is activated; ☞ Page 66.
	The key lock function is activated; ☞ Page 66.
	Answering machine provided in the telephone network. VMWI ¹ - Supplementary service offered by telephone network providers; ☞ Page 67.
<div style="border: 1px solid black; padding: 2px;">Secrecy On</div>	The microphone is deactivated (muted); ☞ Page 66.
	On: The connection to the base station is good. Flashing: The connection to the base station is interrupted. Move nearer to the base station.
	The answering machine is switched on.
	New messages are recorded on the answering machine.

¹ VMWI: Visual Message Waiting Indication = Visual indicator that new messages have been recorded.

Standby mode

All descriptions in this operating manual assume that the handset is in Standby mode. The system switches to Standby mode by pressing the  button.

Energy-save mode

When the handset has been in Standby mode for some time, it automatically switches to energy-save mode. The buttons and display no longer light up. Press  to activate the Standby mode.

Navigation buttons

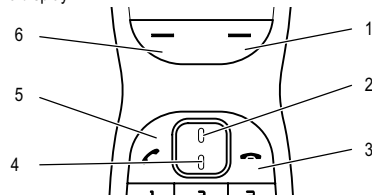

The softkeys (1) and (6) are assigned different functions in the different menus. The function buttons are always referred to in this manual according to the texts directly above them in the display.







Button	In Standby mode	In a menu
1	- Open the phone book menu	- Back
2	- Open the redialling list	- Up
3	- Switch the handset on / off	- Activate the Standby mode / cancel actions
4	- Open the phone book	- Down
5	- Call button / handsfree	
6	- Open the main menu	- Next

Navigating in the menu







All the functions can be accessed via the various menus. Refer to the Menu Structure [☞](#) Page 68 for information on how to access each respective function.

Menu	Open the main menu
 	Text Messaging Select the submenu required

Select	Open the submenu
 /  Write Message	Select the function required
Select	Open the function
	Use the digit keys to enter numbers or letters
Options	Confirm the input
Back	Move one level back
	Aborts all programming and saving and returns the handset to Standby mode
 Every process is automatically cancelled if there is no input within 30 seconds.	

Creating phone book entries - example

The way in which to navigate through the menus and select settings is explained by means of the example **Creating phone book entries**. Proceed as in this example for all the settings.

Names	Open the phone book
 /  Add Entry	Select the submenu and confirm
Select	confirm
Enter Name: 	Enter the name (max. 12 letters) and confirm
OK	
Enter Number: 	Enter the phone number (max. 24 digits) and confirm
Save	confirm
 / 	Select a ringing melody and confirm
Select	

5 Telephoning

Taking a call

  Take the call

Ending a call

 End the call

Making a call

 Enter the phone number (max. 24 digits)

Clear Delete the last digit if incorrect

 Dial the phone number

 It is also possible to press the Call button first to obtain the dialling tone for an outside line. The digits then entered are dialled immediately. It is not possible to correct wrong digits individually using this dialling procedure.

Redialling

The telephone stores the last 20 numbers dialled in a redialling list.

 Open the redialling list

 /  Select an entry and dial the number

Calling back calls received

The telephone stores the numbers of the last 30 calls received in a CID book.

Menu  / 

Calls Lists, Select Open Calls Lists menu

Missed Calls or Received Calls

Select Open the CID book

 /  Select an entry and dial the number

Dialling numbers from the phone book

Phone numbers must have been stored in the phone book for this function;  Pages 65 and 73.

 Open the phone book





 /  Select an entry and dial the number

Telephoning





Internal calls¹



Making internal calls

There must be two or more handsets (HS1, HS2, ...) registered on your base station in order to make internal calls free of charge.

HS1:  , e.g.  , 	Dial the internal call number of the handset required
HS2: 	Take the internal call on the other handset
HS1/HS2: 	End the internal call





Forwarding external calls internally

HS1:  , e.g.  , 	Dial the internal call number during the conversation with the external caller
HS2: 	Take the internal call on the other handset
HS1: 	Transfer the call

 If the handset called does not answer, take the external call back by pressing the  button.







Holding a call / brokering

While a call is in progress, it is possible to dial another handset in order to consult with someone. The external caller is put on hold while you are conversing with the second, internal person called. You can repeat this procedure as often as required.

HS1:  , e.g.  , 	Dial the internal call number during the conversation with the external caller
HS2: 	Take the internal call on the other handset
HS1: 	Switch between callers

Making conference calls

An external call can be transferred to include another internal handset for a conference call.

HS1:  , e.g.  , 	Dial the internal call number during the conversation with the external caller
HS2: 	Take the internal call on the other handset
HS1 	Start the conference
HS1 / HS2: 	End the conference

¹ Internal calls are only possible when at least two handsets are registered in the system  "Checking the contents of the package" on Page 60.

Setting the receiver volume

The volume can be adjusted to one of 8 settings during a call.

 / 	Select the required volume
---	----------------------------

Handsfree

This function is used to listen to the caller via the loudspeaker.



	Activate the handsfree facility
	Deactivate the handsfree facility

Displaying the duration of a call

The duration of a call is displayed in minutes and seconds during the call.

Muting the microphone in the handset

The microphone in the handset can be activated and deactivated during a telephone conversation.

	Deactivate the microphone (muting function)
	Activate the microphone

Key lock

The key lock feature prevents functions assigned to buttons being activated accidentally.



3 sec. 	Activate the key lock function
--	--------------------------------

 , 	Deactivate the key lock function
---	----------------------------------

 Incoming calls can still be taken in the normal way even when the key lock function is activated.

Searching for the handset (Paging)

If you have mislaid your handset, you can sound a paging tone to find it.

	Start the search tone
 or 	End the search tone

Switching the handset off and on

You can switch the handset off to save the batteries.

3 sec. 	Switch the handset off
3 sec. 	Switch the handset on

6 PABX / Supplementary Services

R function in private branch exchanges

If the telephone is connected to a private branch exchange (PABX), functions such as transferring calls and automatic call back can be used via the R button. Refer to the operating manual provided with your private branch exchange as to which Flash time must be set in order to use these functions. The sales outlet where you purchased the exchange can provide information as to whether the telephone will work properly with the exchange. The Flash time is set using the menu. Refer to Page 71 for the (Recall Mode) menu option.

R function and supplementary services

Your telephone supports supplementary services provided by your telephone network provider, such as brokering, call waiting and conference facilities. Press the **R** button to use the supplementary services. Please contact your telephone network provider regarding which Flash time must be set to use the supplementary services. Also contact your telephone network provider with regard to enabling supplementary services. The Flash time is set using the menu. Refer to Page 71 for the (Recall Mode) menu option.

Caller number display (CLIP¹)



The caller number display (CLIP) is a supplementary service offered by your telephone network provider. Contact your network provider for further information.

If this function is available with your telephone line, the number of the caller appears in the display when the phone rings. If the caller has suppressed transmission of his phone number, the corresponding message appears in the display. The phone number is not displayed and, as a result, is not stored in the CID book.

¹ **CLIP**: Calling Line Identification Presentation = Displays the caller's phone number.

Dialling pause

When using private branch exchanges, it is necessary to dial an access code to obtain the dialling tone for an outside line. When using some older private branch exchanges, it takes a little time before the dialling tone becomes audible. In the case of such private branch exchanges, a dialling pause can be inserted after the number for an outside line in order to continue dialling directly without having to wait for the dialling tone.

3 sec.

Insert a dialling pause

The actual phone number is dialled a certain time after the number for an outside line.



The dialling pause can also be entered with the phone numbers in the phone book.

Answering machine in the telephone network

An answering machine in the telephone network is a supplementary service offered by many telephone network providers. If your telephone network provider offers an answering machine in the telephone network for you, an icon on the display informs you of new messages received (**VMWI**²). This function can only be used when your telephone network provider actually offers the service. Contact your network provider for further information.



² **VMWI**: Visual Message Waiting Indication = Visual indicator that new messages have been recorded.

Menu Structure

7 Menu Structure

Main menu

Access the Main menu by pressing the **Menu** softkey. The way to navigate through the menu and make entries and selections is described on Page 64.

Text Messaging	Write Message		Options	Send	Enter Number: 	Send
				Save		
				Insert Symbol		
				Insert Emoticon		
				Insert Template		
	Inbox	Read	Options	Reply		
				Forward		
				Message Details		
				Use Number		
				Delete		
	Drafts	Edit	Options	see Write Message		
	Outbox	Read	Options	Forward		
				Delete	Yes / No	
	Templates	Options	Edit			
			Delete	Yes / No		
	Delete Messages	Inbox	Yes / No			
		Drafts	Yes / No			
		Outbox	Yes / No			
		All Messages	Yes / No			
Text Settings	Service Centres	Set Send Centre	Send Centre 1			
			Send Centre 2			

Menu Structure



	Receive Centres	Receive Centre 1 - 2	Enter Number:	Save
	Send Centres	Send Centre 1 - 2	Enter Number:	Save
Mailbox Number		Save		
Message Size	160 Characters			
	612 Characters			
Message Alert	On/Off			
Users	User 1 - 4	Options	Edit	Enter Name:
			Delete	Yes / No

Calls Lists	Missed Calls	Options	Show Details	
			Save Number	Enter Name: Enter Number:
			Send Message	
			Delete Call	
	Received Calls	Options	see Missed Calls	
	Dialled Calls	Options	see Missed Calls	
	Delete Calls	Missed Calls, Received Calls, Dialled Calls		Yes / No

Agenda	Options	Add Event	Enter Date:	Enter Time:	Silent
					Alarm
					Once/ Annually
		Show Details			
		Edit Event	Enter Date:	Enter Time:	Silent
					Alarm
					Once/ Annually
		Send as a Text	Options	Send	Enter Number:
					Send

Menu Structure

		Save
		Insert Symbol
		Insert Emoticon
		Insert Template
Delete Event	Delete Event ?	Yes / No
Delete All Events	Delete All Events ?	Yes / No

Clock & Alarm	Date & Time	Enter Date: 	Enter Time: 
	Alarm	Off/On	
	Time Format	12 Hour	
		24 Hour	

Settings	Set Handset	Ringtone	External Call	Melody 1 - 20
			Internal Call	Melody 1 - 20
		Ringer Volume	Ringer Off	
			Volume 1 - 5	
		Receiver Volume	Volume 1 - 8	
		Handset Name		
		Language	English (UK)	
			Français	
			Deutsch	
			Italiano	
			Español	

Set Base	Screensaver	Clock / Off	
	Light Timeout	15 Seconds	
		30 Seconds	
		45 Seconds	
	Auto Talk	Off/On	
	Key Beep	Off/On	
	PBX Access Code	Off/On	
		Set Code	
	Ringtone	Melody 1 - 5	
	Ringer Volume	Default Melody	
		Ringer Off	Volume
	Dialling Mode	Pulse	
		Tone	
	Recall Mode	Recall 1	
		Recall 2	
First Ring	On/Off		
System PIN	Enter Old PIN:	Enter New PIN:	Re-enter PIN:
Master Reset	Are you sure ?	Yes / No	Enter System PIN:
ECO Mode	Off/Eco Mode		

Registration	Register Handset	Base 1- 4	Enter System PIN:
	Select Base	Base 1- 4	Enter System PIN:
	De-register		

Menu Structure

Names	Options	Show Details																																																																																										
		<table border="1"> <tr> <td>Send Message</td> <td>Options</td> <td>Send</td> <td>Enter Number: </td> <td>Send</td> </tr> <tr> <td></td> <td></td> <td>Save</td> <td></td> <td></td> </tr> <tr> <td></td> <td></td> <td>Insert Symbol</td> <td></td> <td></td> </tr> <tr> <td></td> <td></td> <td>Insert Emoticon</td> <td></td> <td></td> </tr> <tr> <td></td> <td></td> <td>Insert Template</td> <td></td> <td></td> </tr> <tr> <td>Edit Entry</td> <td>Enter Name: </td> <td>Enter Number: </td> <td>Melody 1- 20</td> <td></td> </tr> <tr> <td></td> <td></td> <td></td> <td>Default Melody</td> <td></td> </tr> <tr> <td>Copy Entry</td> <td>To HS or Base</td> <td></td> <td></td> <td></td> </tr> <tr> <td>Ringtone</td> <td>Melody 1 - 20</td> <td></td> <td></td> <td></td> </tr> <tr> <td></td> <td>Default Melody</td> <td></td> <td></td> <td></td> </tr> <tr> <td>Delete Entry</td> <td>Yes / No</td> <td></td> <td></td> <td></td> </tr> <tr> <td>Quickdial</td> <td>Key 1 - 3</td> <td>Assign</td> <td></td> <td></td> </tr> <tr> <td></td> <td></td> <td>Clear Entry</td> <td></td> <td></td> </tr> <tr> <td>Add Entry</td> <td>Enter Name: </td> <td>Enter Number: </td> <td>Melody 1- 20</td> <td></td> </tr> <tr> <td></td> <td></td> <td></td> <td>Default Melody</td> <td></td> </tr> <tr> <td>Copy Phonebook</td> <td>To HS or Base</td> <td></td> <td></td> <td></td> </tr> <tr> <td>Memory Status</td> <td></td> <td></td> <td></td> <td></td> </tr> <tr> <td>Delete Phonebook</td> <td>Delete All Entries ?</td> <td>Yes / No</td> <td></td> <td></td> </tr> </table>	Send Message	Options	Send	Enter Number:	Send			Save					Insert Symbol					Insert Emoticon					Insert Template			Edit Entry	Enter Name:	Enter Number:	Melody 1- 20					Default Melody		Copy Entry	To HS or Base				Ringtone	Melody 1 - 20					Default Melody				Delete Entry	Yes / No				Quickdial	Key 1 - 3	Assign					Clear Entry			Add Entry	Enter Name:	Enter Number:	Melody 1- 20					Default Melody		Copy Phonebook	To HS or Base				Memory Status					Delete Phonebook	Delete All Entries ?	Yes / No		
Send Message	Options	Send	Enter Number:	Send																																																																																								
		Save																																																																																										
		Insert Symbol																																																																																										
		Insert Emoticon																																																																																										
		Insert Template																																																																																										
Edit Entry	Enter Name:	Enter Number:	Melody 1- 20																																																																																									
			Default Melody																																																																																									
Copy Entry	To HS or Base																																																																																											
Ringtone	Melody 1 - 20																																																																																											
	Default Melody																																																																																											
Delete Entry	Yes / No																																																																																											
Quickdial	Key 1 - 3	Assign																																																																																										
		Clear Entry																																																																																										
Add Entry	Enter Name:	Enter Number:	Melody 1- 20																																																																																									
			Default Melody																																																																																									
Copy Phonebook	To HS or Base																																																																																											
Memory Status																																																																																												
Delete Phonebook	Delete All Entries ?	Yes / No																																																																																										

8 Phone Book

You can use the phone book to store up to 250 phone numbers together with the associated names.

- The phone book entries are arranged alphabetically. To access the required phone book entry directly, press the first letters of the corresponding name.

Entering names

Letters are also imprinted on the digit keys. Letters, digits and special characters are entered by pressing the relevant key the respective number of times.

	Enter a space
Clear	Delete
or	Enter the special character
	To enter the same letter twice, press the button to enter the letter. Wait until the cursor skips one position forwards. Enter the letter again.

Creating phone book entries

Refer to the example; Page 65.

Modifying phone book entries

Names	Open the main menu
/ Search	Select the phone book
Select	and confirm it
/ Options	Select the phone book entry and confirm it
/ Edit Entry	Select the submenu and confirm it
Select	
Enter Name: OK	Change the name and confirm it
Enter Number:	Change the phone number and confirm it
Save	
Melody 1 - 20	Select a ringing melody and store it
Select	

¹ CLIP: Calling Line Identification Presentation = Displays the caller's phone number.

Deleting phone book entries

Deleting an entry

Names	Open the main menu
/ Search	Select the phone book
Select	and confirm it
/ Options	Select the phone book entry and confirm it
/ Delete Entry	Select the submenu and confirm it
Select	
Delete? Yes / No	Confirm the deleting process or cancel it

Deleting all entries

Names	Open the main menu
/	
Delete Phonebook	Select the submenu and confirm it
Select	
Delete All Entries ?	Confirm the deleting process or cancel it
Yes / No	

9 CID Book

A total of 30 phone numbers are stored in the CID Book (call log).



The caller number display (CLIP¹) is a supplementary service offered by your telephone network provider. The caller's number appears in the display if the service is offered by your telephone network provider. Contact your network provider for further information.

Show/dial phone numbers on the calls list















Menu	Open the main menu
/ Calls Lists	Select the submenu and confirm it
Select	
Missed Calls or Received Calls	
Select	Open the CID book

Special Functions

 Dial the phone number

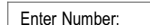







Storing a phone number in the CID book in the phone book

A phone number in the CID book can be stored in the phone book directly.

	Open the main menu
 /  Calls Lists	Select the submenu and confirm it
	confirm it
Missed Calls or Received Calls	
	Open the CID book
 /  , Options	Select entry and confirm
Save Number, 	Open the function
Enter Name:  ,  OK	Enter the name (max. 12 characters) and confirm it
Enter Number:  , 	Modify phone number and confirm it
	
Melody 1 - 20	Select a ringing melody and store it
	







Deleting phone numbers from the CID book

Deleting individual phone numbers

	Open the main menu
 /  Calls Lists	Select the submenu and confirm it
	confirm it
Missed Calls or Received Calls	
	Open the CID book
 /  , Options	Select entry and confirm
Delete Call, 	Confirm function

Deleting all phone numbers

	Open the main menu
---	--------------------

 /  Calls Lists	Select the submenu and confirm it
	confirm it
 /  Delete Calls	Open the submenu
Missed Calls or Received Calls	or
Dialled Calls or All Calls	
	Select Calls list
Delete All Calls ?	Confirm the deleting process or cancel it
Yes / No	

10 Special Functions

Dialling mode

The telephone can be operated in analogue exchanges (PULSE mode) as well as new, digital exchanges (TONE/DTMF mode). The dialling mode is controlled via the menu. Refer to Page 71 for the sequence of menu option selections.

Temporary tone dialling

If you only operate the telephone using the PULSE dialling mode, you can still make use of the advantages of the TONE dialling mode (e.g.: remote access of the answering machine in the telephone network). You can temporarily switch to Tone dialling when a connection has already been made.

2 sec.  Press when a connection has been established

When the call is ended, the equipment automatically switches back to Pulse dialling.





Alarm

The "Alarm clock" function can be used so that you are alerted by the handset at a specific time. Refer to Page 70 for the sequence of menu option selections.

Agenda

Your telephone can memorise up to 5 entries (such as birthdays) to remind you of the event on the correct date. Entries can be up to 24 characters long.

Creating agenda entries

	Open the main menu
 /  Agenda	Select Agenda and confirm it
	

Options	Add Event	Select
Select		and confirm
	Save	Enter a subject and confirm
	Save	Enter a date and confirm
	Save	Enter a time and confirm
▼ / ▲	Silent	or
Alarm	Select	Select a type of reminder and confirm
If you selected Alarm :		
▼ / ▲	Once	or
Annually	Select	Select an interval and confirm
▼ / ▲	At event time	or
30 min before	Select	Select a reminder time and confirm

For further steps refer to the Menu Structure on Page 69.

11 SMS - Text Messages

Conditions for using SMS

The telephone connection must be equipped with the **CLIP**¹ feature. Contact your telephone network provider to ensure this feature is enabled on your telephone connection. To use the **SMS**² service, your telephone network provider must enable it.

- A text cannot be sent from every private branch exchange extension.



If you want to send SMS text messages from a private branch exchange extension, it is necessary to store the number for an outside line for your PBX in the handset preceding the Service Centre number.

- Sending SMS messages is not available for Call-by-Call connections at present.
- Sending SMS messages is liable to costs.
- If the recipient in the conventional telephone network does not use an SMS service or his telephone is not basically equipped to handle SMS messages, the SMS is automatically converted to a voice message.
- Costs are charged by your telephone network provider.

¹ **CLIP**: Calling Line Identification Presentation = Display the caller's phone number.

² **SMS**: Short Message Service = Service for sending text messages.

SMS Service Centre

SMS messages are distributed via a Service Centre. If you want to send SMS text messages, you must first program a service centre number in your handset Page 11. Please contact the provider of your choice for the necessary service centre call numbers and the procedure for enabling the SMS service.



Your telephone has already been prepared to send SMS text messages. Service centre numbers are already programmed in the handset. Activate the required Service Centre in the SMS menu Page 11.

Send Centre 1	Send Centre 2
Swisscom: 0622100000	Cablecom: 0435375370

Entering text

The digit keys are also labelled with letters for the entry of the respective text. Letters, digits and special characters are entered by pressing the relevant key the respective number of times. Please refer to the Menu Structure for a description of the navigation for writing texts Page 68.

	Switch between upper and lower case
Clear	Delete the last character entered

3 sec. Clear Delete the entire text

SMS text templates

There are 5 pre-programmed text templates available Page 68.

SMS alert signal (alarm)

An acoustic signal is issued when a new SMS text message is received. The signal can be activated or deactivated via the menu. Refer to Page 11 for the sequence of menu options.

12 Extending the Telephone System

The internationally approved **GAP**¹ standard regulates the compatibility of handsets and base stations from different manufacturers. As a result, it is possible to integrate SWI-TEL devices and equipment from other manufacturers together in one telephone system. It is possible, however, that some functions are not available.

Multiple handsets

Up to 5 handsets can be registered on the base station.

¹ **GAP**: Generic Access Profile = Standard for the interoperation of handsets and base stations from different manufacturers.



In Case of Problems

Registering handsets

Before starting to register a handset, switch the base station to Registration mode. Press and hold the Paging button on the base station until you hear an acoustic signal. The base station is then in Registration mode for the following 60 seconds. Continue with the handset.

2 sec. 

Activate Registration mode

Now register the handset  Page 72. The currently valid PIN code is used for registration purposes;  Page 71.

The handset is automatically assigned an internal call number following registration.



To register handsets from other manufacturers, please refer to the operating manual supplied with them.

Deregistering handsets



Each handset can be used to deregister other handsets registered on this base station.

Handsets are deregistered via the menu. Refer to Page 72 for the sequence of menu option selections.

Multiple base stations

You can increase the range of your handset by registering it on several base stations.

The handset can be registered on up to 4 different base stations simultaneously. Each base station requires its own telephone line socket. Connections can be used with the same call number or with different ones.



Calls in progress cannot be transferred from one base station to another.



13 In Case of Problems

Service Hotline

Should problems arise with the telephone, please refer to the following information first. In the case of technical problems, you can contact our hotline service, Tel. 0900 00 1675 within Switzerland (Swisscom fees at time of going to print: CHF 2.60/min). In the case of claims under the terms of guarantee, please contact your sales outlet. There is a 2 year period of guarantee.

Problems and solutions

Problems	Solutions
No connection to base station possible	- Check that the handset has been registered on the base station with the correct PIN code;  Page 71.

Problems	Solutions
No telephone calls possible	<ul style="list-style-type: none"> - The telephone is not connected properly or is defective. Only use the telephone connection cable supplied. - Test whether the telephone connection is in order by using another telephone. - The power adaptor plug is not plugged in or there is a complete power failure. - The rechargeable battery pack is empty or defect. - The handset is too far from the base station. - The wrong dialling mode is set;  Page 71.
Connection is disturbed or cut off	<ul style="list-style-type: none"> - The handset is too far from the base station. - The base station is in an unsuitable location.
The system no longer responds	<ul style="list-style-type: none"> - Return all the functions to their default status using the "Master Reset" function;  Page 71. - Disconnect the power adapter plug briefly from the power socket.
The rechargeable batteries are empty in a short time	<ul style="list-style-type: none"> - The rechargeable batteries are empty or defect. - Place the handset in the base station properly. Clean the contact surfaces on the handset and base station with a soft, dry cloth. - Place the handset in the base station for 15 hours.
The caller number display (CLIP ¹) does not function	<ul style="list-style-type: none"> - The caller number display (CLIP) is a supplementary service offered by your telephone network provider. Contact your network provider for further information. - The caller has suppressed the transmission of their phone number.

¹ CLIP: Calling Line Identification Presentation = Displays the caller's phone number.

14 Technical Properties

Technical data

Feature	Value
Standard	DECT ¹ -GAP ²
Power supply (base station, transparent plug)	Input: 100-240 V, 50/60 Hz Output: 7.5 V 300 mA
Power supply (charging station, red plug)	Input: 100-240 V, 50/60 Hz Output: 7.5 V, 200 mA
Range	Outdoors: Approx. 300 m Indoors: Approx. 50 m
Standby mode	Up to 100 h
Max. talk time	Up to 10 h
Rechargeable batteries	AAA NiMH 1.2 V
Dialling mode	Tone dialling mode Pulse dialling mode
Permissible ambient temperature	Normal: 15 °C to 35 °C Extreme: 0 °C to 40 °C
Permissible relative humidity	0% to 90%
Flash times	100 ms, 300 ms

¹ DECT: Digital Enhanced Cordless Telecommunication = Standard for cordless telephones.

² GAP: Generic Access Profile = Standard for the interoperation of handsets and base stations from different manufacturers.

Default settings

Handset

Alarm	Off
Ringer Volume	Volume5
Ringtone External Call / Ringtone Internal Call	Melody 1 / Melody 2
Receiver Volume	Volume4
Key Beep	On
Screensaver	Off
Language	Deutsch
Handset Name	DF 1001
Auto Talk	On
Time Format	24 Hour

Base station

The default settings can be restored via the menu.
Refer to Page 71 for the sequence of menu option selections.

Dialling Mode	Tone
Flash time (Recall Mode)	100 ms (Recall 1)
System PIN	0000

Maintenance / Guarantee

Declaration of Conformity

This device fulfils the requirements stipulated in the EU directive: 1999/5/EC directive on radio equipment and telecommunications terminal equipment and the mutual recognition of their conformity. Conformity with the above mentioned directive is confirmed by the CE symbol on the device. To view the complete Declaration of Conformity, please refer to the free download available on our web site at www.switel.com.



15 Maintenance / Guarantee

Maintenance

- Clean the housing surfaces with a soft, fluff-free cloth.
- Do not use any cleaning agents or solvents.

Guarantee

SWITEL equipment is produced and tested according to the latest production methods. The implementation of carefully chosen materials and highly developed technologies ensure trouble-free functioning and a long service life. The terms of guarantee do not apply where the cause of equipment malfunction is the fault of the telephone network operator or any interposed private branch extension system. The terms of guarantee do not apply to the batteries or power packs used in the products. The period of guarantee is 24 months from the date of purchase.

All deficiencies related to material or manufacturing errors within the period of guarantee will be redressed free of charge. Rights to claims under the terms of guarantee are annulled following tampering by the purchaser or third parties. Damage caused as the result of improper handling or operation, normal wear and tear, incorrect positioning or storage, improper connection or installation or Acts of God and other external influences are excluded from the terms of guarantee. In the case of complaints, we reserve the right to repair defect parts, replace them or replace the entire device. Replaced parts or devices become our property. Rights to compensation in the case of damage are excluded where there is no evidence of intent or gross negligence by the manufacturer.

If your device does show signs of a defect within the period of guarantee, please contact the sales outlet where you purchased the SWITEL device, producing the purchase receipt as evidence. All claims under the terms of guarantee in accordance with this agreement can only be asserted at the sales outlet. No claims under the terms of guarantee can be asserted after a period of two years from the date of purchase and hand-over of the product.

SWITEL

Declaration of Conformity

Diese Anlage entspricht der europäischen R&TTE Richtlinie.

Für die komplette Konformitätserklärung nutzen Sie bitte den kostenlosen Download von unserer Website www.switel.com.

Cet équipement est conforme à la directive européenne R&TTE.

Pour obtenir la déclaration de conformité intégrale, veuillez vous servir du téléchargement gratuit de notre site Internet www.switel.com.

Quest'apparecchiatura è conforme alla direttiva europea R&TTE.

Per la dichiarazione di conformità completa si prega di voler usufruire del servizio gratuito di download dal nostro sito Internet www.switel.com.

This equipment complies with the European R&TTE directive.

To view the complete Declaration of Conformity, please refer to the free download available at our web site: www.switel.com.

Service Hotline

Bei technischen Problemen können Sie sich an unsere Service-Hotline unter Tel. 0900 00 1675 innerhalb der Schweiz
(Kosten Swisscom bei Drucklegung: CHF 2.60/min) wenden.

S'il s'agit de problèmes techniques, vous pouvez vous adresser à notre hotline de service en Suisse en appelant le numéro 0900 00 1675
(frais Swisscom à la date d'impression de ce manuel : CHF 2.60/min).

In caso di problemi tecnici è possibile rivolgersi alla nostra hotline di assistenza tecnica chiamando al numero 0900 00 1675 valido per la Svizzera
(spese da rete Swisscom alla data di stampa: CHF 2.60 / min).

In the event of technical problems, you can contact our hotline service, Tel. 0900 00 1675 within Switzerland
(cost via Swisscom at time of going to print: CHF 2.60/min).

